



**Terrestrial Trunked Radio (TETRA);
Testing specification;
Part 1: Radio**

Reference

RTS/TCCE-04197

Keywords

DMO, testing, TETRA, V+D

ETSI

650 Route des Lucioles
F-06921 Sophia Antipolis Cedex - FRANCE

Tel.: +33 4 92 94 42 00 Fax: +33 4 93 65 47 16

Siret N° 348 623 562 00017 - NAF 742 C
Association à but non lucratif enregistrée à la
Sous-Préfecture de Grasse (06) N° 7803/88

Important notice

The present document can be downloaded from:

<http://www.etsi.org/standards-search>

The present document may be made available in electronic versions and/or in print. The content of any electronic and/or print versions of the present document shall not be modified without the prior written authorization of ETSI. In case of any existing or perceived difference in contents between such versions and/or in print, the prevailing version of an ETSI deliverable is the one made publicly available in PDF format at www.etsi.org/deliver.

Users of the present document should be aware that the document may be subject to revision or change of status.

Information on the current status of this and other ETSI documents is available at

<https://portal.etsi.org/TB/ETSIDeliverableStatus.aspx>

If you find errors in the present document, please send your comment to one of the following services:

<https://portal.etsi.org/People/CommiteeSupportStaff.aspx>

Copyright Notification

No part may be reproduced or utilized in any form or by any means, electronic or mechanical, including photocopying and microfilm except as authorized by written permission of ETSI.

The content of the PDF version shall not be modified without the written authorization of ETSI.

The copyright and the foregoing restriction extend to reproduction in all media.

© ETSI 2021.

All rights reserved.

DECT™, **PLUGTESTS™**, **UMTS™** and the ETSI logo are trademarks of ETSI registered for the benefit of its Members.

3GPP™ and **LTE™** are trademarks of ETSI registered for the benefit of its Members and of the 3GPP Organizational Partners.

oneM2M™ logo is a trademark of ETSI registered for the benefit of its Members and of the oneM2M Partners.

GSM® and the GSM logo are trademarks registered and owned by the GSM Association.

Contents

Intellectual Property Rights	11
Foreword.....	11
Modal verbs terminology.....	11
Introduction	11
1 Scope	12
2 References	12
2.1 Normative references	12
2.2 Informative references.....	13
3 Definition of terms, symbols and abbreviations.....	13
3.1 Terms.....	13
3.2 Symbols.....	13
3.3 Abbreviations	14
4 General	16
4.1 Presentation of equipment for testing purposes.....	16
4.1.1 Facilities and information required for testing	16
4.1.2 Choice of radio frequency channels to be tested.....	17
4.1.3 Interpretation of the measurement results	17
4.2 Mechanical and electrical design.....	18
4.2.1 General.....	18
4.2.2 Controls	18
4.2.3 Void	18
5 Radio test configuration, test signals and test modes	18
5.0 Outline.....	18
5.1 General functional radio test configuration	18
5.2 Radio test modes	19
5.2.0 Manufacturer provisions	19
5.2.1 Test receive mode	19
5.2.1.0 Slot width requirements	19
5.2.1.1 MS test receive mode for phase modulation	19
5.2.1.2 BS test receive mode for phase modulation	20
5.2.1.3 MS test receive mode for QAM (where supported)	20
5.2.1.4 BS test receive mode for QAM (where supported)	21
5.2.2 Test transmit mode.....	22
5.2.2.1 MS testing for phase modulation	22
5.2.2.2 Void.....	22
5.2.2.3 BS testing for phase modulation	22
5.2.2.4 MS testing for QAM (where supported)	22
5.2.2.5 BS testing for QAM (where supported)	23
5.3 Radio test signals.....	24
5.3.1 General.....	24
5.3.2 Test signal T1 (TETRA wanted signal, phase modulation)	24
5.3.2.0 T1 signal requirements	24
5.3.2.1 MS testing	24
5.3.2.2 BS testing	25
5.3.2.3 Void.....	26
5.3.2.4 Void.....	26
5.3.3 Test signal T2 (TETRA interferer)	26
5.3.4 Test signal T3 (unmodulated interferer)	26
5.3.5 Test signal T4 (TETRA wanted signal, QAM).....	26
5.3.5.0 T4 signal requirements.....	26
5.3.5.1 MS testing	26
5.3.5.1.0 Test transmission requirements	26
5.3.5.1.1 Use of synchronization burst in frame 18 when testing CA MSs.....	28

5.3.5.1.1a	Use of frequency correction burst in frame 18 when testing DA MSs	30
5.3.5.2	BS testing	31
6	Test conditions	32
6.1	General	32
6.2	Power sources and ambient conditions.....	32
6.2.0	General.....	32
6.2.1	Normal test conditions	32
6.2.2	Extreme test conditions.....	33
6.3	Procedure for tests at extreme temperatures.....	34
6.3.0	Thermal balance.....	34
6.3.1	Equipment designed for continuous operation.....	34
6.3.2	Equipment designed for intermittent operation.....	34
7	Technical characteristics	34
7.1	Transmitter parameter definitions and limits.....	34
7.1.1	Transmitter output power.....	34
7.1.1.1	Definition	34
7.1.1.2	Limit values for phase modulation and QAM.....	35
7.1.2	Unwanted output power in non-active transmit state.....	35
7.1.2.1	Definition	35
7.1.2.2	Limit values.....	35
7.1.3	Adjacent channel power due to modulation.....	36
7.1.3.1	Definition	36
7.1.3.2	Limit values for phase modulation.....	36
7.1.3.3	Limit values for QAM.....	36
7.1.4	Adjacent channel power due to switching transients	37
7.1.4.1	Definition	37
7.1.4.2	Limit values for phase modulation.....	37
7.1.4.3	Limit values for QAM.....	37
7.1.5	Unwanted emissions far from the carrier	38
7.1.5.1	Definition	38
7.1.5.2	Limit values for phase modulation.....	38
7.1.5.3	Limit values for QAM.....	39
7.1.6	Unwanted radiated emissions	40
7.1.6.1	Definition	40
7.1.6.2	Limit values.....	40
7.1.7	Unwanted emissions during the BLCH/CLCH (linearization)	40
7.1.7.1	Definition	40
7.1.7.2	Limit values for phase modulation.....	41
7.1.7.3	Limit values for QAM.....	41
7.1.8	Transmitter intermodulation attenuation.....	41
7.1.8.1	Definition	41
7.1.8.2	Limit values for phase modulation and QAM.....	41
7.1.8.2.1	MS Limit values	41
7.1.8.2.2	Limit values for single BS transmitter	41
7.1.8.2.3	Limit values for intra BS intermodulation.....	42
7.2	Receiver parameter definitions and limits	42
7.2.1	General.....	42
7.2.2	Nominal error rates	42
7.2.2.1	Definition	42
7.2.2.2	Limit values for phase modulation.....	42
7.2.2.3	Limit values for QAM.....	43
7.2.3	Reference sensitivity performance.....	43
7.2.3.1	Definition	43
7.2.3.2	Limit values for phase modulation.....	43
7.2.3.3	Limit values for QAM.....	44
7.2.4	Reference interference performance	45
7.2.4.1	Definition	45
7.2.4.2	Limit values for phase modulation.....	46
7.2.4.3	Limit values for QAM.....	46
7.2.4.3.1	Adjacent channel interference	46

7.2.4.3.2	Co-channel interference.....	47
7.2.5	Blocking characteristics.....	47
7.2.5.1	Definition.....	47
7.2.5.2	Limit values for phase modulation.....	47
7.2.5.3	Limit values for QAM.....	48
7.2.6	Spurious response rejection.....	49
7.2.6.1	Definition.....	49
7.2.6.2	Limit values for phase modulation.....	49
7.2.6.3	Limit values for QAM.....	49
7.2.7	Intermodulation response rejection.....	49
7.2.7.1	Definition.....	49
7.2.7.2	Limit values.....	50
7.2.8	Unwanted conducted emissions.....	50
7.2.8.1	Definition.....	50
7.2.8.2	Limit values.....	50
7.2.9	Unwanted radiated emissions.....	50
7.2.9.1	Definition.....	50
7.2.9.2	Limit values.....	51
7.3	Transmitter/receiver parameter definitions and limits.....	51
7.3.1	Modulation accuracy.....	51
7.3.1.1	Definition.....	51
7.3.1.2	Limit values for phase modulation.....	51
7.3.1.3	Limit values for QAM.....	51
7.3.2	Carrier frequency accuracy.....	51
7.3.2.1	Definition.....	51
7.3.2.2	Limit values.....	51
7.3.3	MS receiver performance for synchronization burst acquisition.....	52
7.3.3.1	Definition for phase modulation.....	52
7.3.3.2	Limit values for phase modulation.....	52
7.3.3.3	Definition for QAM modulation.....	52
7.3.3.4	Limit values for QAM modulation.....	52
7.3.4	MS Frame alignment performance.....	53
7.3.4.1	Definition.....	53
7.3.4.2	Limit values.....	53
7.3.5	MS link control.....	53
7.3.5.1	Definition.....	53
7.3.5.2	Limit values.....	53
8	Methods of measurement for transmitter parameters.....	54
8.1	Transmitter output power.....	54
8.1.0	Test conditions.....	54
8.1.1	Transmitter output power for phase modulation.....	54
8.1.1.1	MS transmitter output power for phase modulation.....	54
8.1.1.2	BS transmitter output power for phase modulation.....	55
8.1.2	Transmitter output power for QAM.....	55
8.1.2.1	MS transmitter output power for QAM.....	55
8.1.2.2	BS transmitter output power for QAM.....	56
8.2	Unwanted output power in non active transmit state.....	57
8.3	Adjacent channel power due to modulation.....	57
8.4	Adjacent channel power due to switching transients.....	58
8.5	Unwanted emissions far from the carrier.....	58
8.6	Unwanted radiated emissions.....	60
8.7	Unwanted emissions during the BLCH/CLCH and BLCH-Q/CLCH-Q (linearization).....	60
8.7.0	Test conditions.....	60
8.7.1	MS unwanted emissions during the CLCH (linearization).....	60
8.7.2	BS unwanted emissions during the BLCH (linearization).....	61
8.7.3	MS unwanted emissions during the CLCH-Q (linearization).....	61
8.7.4	BS unwanted emissions during the BLCH-Q (linearization).....	61
8.8	Transmitter intermodulation attenuation.....	62
8.8.0	Test procedure.....	62
8.8.1	MS Transmitter intermodulation attenuation.....	62
8.8.2	BS Transmitter intermodulation attenuation.....	62

8.8.3	Intra BS transmitter intermodulation attenuation.....	62
9	Methods of measurement for receiver parameters	63
9.1	General	63
9.2	Nominal error rates for phase modulation.....	63
9.2.0	Test conditions.....	63
9.2.1	MS nominal error rate.....	63
9.2.2	BS nominal error rate.....	63
9.3	Reference sensitivity performance	63
9.3.0	Test conditions.....	63
9.3.1	MS reference sensitivity performance for phase modulation.....	64
9.3.2	BS reference sensitivity performance for phase modulation	64
9.3.3	MS reference sensitivity performance for QAM	64
9.3.4	BS reference sensitivity performance for QAM	64
9.3.5	PUEM performance	65
9.4	Reference interference performance.....	65
9.4.0	Test conditions.....	65
9.4.1	MS reference interference performance for phase modulation	65
9.4.2	BS reference interference performance for phase modulation.....	65
9.4.3	MS reference interference performance for QAM.....	66
9.4.4	BS reference interference performance for QAM.....	66
9.5	Blocking characteristics	66
9.5.0	Test conditions.....	66
9.5.1	MS blocking for phase modulation.....	67
9.5.2	BS blocking for phase modulation.....	67
9.5.3	MS blocking for QAM.....	67
9.5.4	BS blocking for QAM.....	67
9.6	Spurious response rejection.....	68
9.6.0	Test conditions.....	68
9.6.1	Phase Modulation	68
9.6.2	QAM.....	68
9.7	Intermodulation response rejection	68
9.7.0	Test conditions.....	68
9.7.1	MS intermodulation response rejection for phase modulation.....	68
9.7.2	BS intermodulation response rejection for phase modulation	69
9.7.3	MS intermodulation response rejection for QAM	69
9.7.4	BS intermodulation response rejection for QAM	69
9.8	Unwanted emissions.....	70
9.9	Unwanted radiated emissions	70
10	Methods of measurement for transmitter/receiver parameters	70
10.1	Modulation accuracy	70
10.1.0	Test conditions.....	70
10.1.1	MS modulation accuracy for phase modulation.....	71
10.1.2	BS modulation accuracy for phase modulation	71
10.1.3	Vector error magnitude at symbol time for phase modulation.....	71
10.1.4	MS modulation accuracy for QAM	71
10.1.5	BS modulation accuracy for QAM	71
10.1.6	Vector error magnitude at symbol time for QAM	72
10.2	Carrier frequency accuracy.....	72
10.2.0	Test set-up.....	72
10.2.1	MS carrier frequency accuracy for phase modulation	72
10.2.2	BS carrier frequency accuracy for phase modulation	73
10.2.3	MS carrier frequency accuracy for QAM	73
10.2.4	BS carrier frequency accuracy for QAM	74
10.3	MS receiver performance for synchronization acquisition.....	74
10.3.1	CA MS receiver performance for synchronization burst acquisition.....	74
10.3.2	DA MS receiver performance for frequency correction burst acquisition.....	75
10.4	MS Frame alignment performance.....	75
10.5	MS link control.....	75
11	Measurement uncertainty	76
11.0	Tolerances and uncertainties	76

11.1	Transmitter	77
11.2	Receiver.....	80
11.3	Transmitter/receiver parameter definitions and limits.....	82
11.4	Interpretation of measurement results	83
Annex A (normative): TETRA receiver testing.....		84
A.1	Frequencies of spurious response.....	84
A.2	Test cases and test conditions for BS and MS receivers	84
A.3	Test signal T1/T4, content of BSCH, BSCH-Q/T, BNCH/T and BNCH-Q/T.....	109
Annex B (normative): Radio test system functions.....		115
B.1	Test transmitter and receiver	115
B.1.1	General	115
B.1.2	Sampling system	115
B.1.2.1	General.....	115
B.1.2.2	TETRA filter.....	115
B.1.2.3	Adjacent channel power measurements.....	116
B.1.2.4	Modulation accuracy measurements.....	116
B.1.2.5	Measurement of unwanted output power in the non-active transmit state.....	116
B.1.3	Spectrum analyser	116
B.1.4	Error rate tester.....	116
B.1.5	Test signal requirements.....	117
B.1.5.1	On channel test signal T1.....	117
B.1.5.2	Interfering test signal T2.....	117
B.1.5.2.1	Phase Modulated	117
B.1.5.2.2	QAM Modulated	117
B.1.5.3	Interfering test signal T3.....	117
B.1.5.4	On channel test signal T4.....	118
B.1.6	Propagation simulators	118
B.1.7	Timing measurement unit.....	118
B.1.8	Passive test system components	118
B.1.9	Test system controller	118
Annex C (normative): TETRA Test Connector Interface (TTCI).....		119
C.1	General	119
C.2	Formal aspects.....	119
C.3	TTCI, layer 1	120
C.3.1	Mechanical and electrical characteristics	120
C.3.2	Transmission and reception characteristics	120
C.4	TTCI, Layer 2.....	120
C.4.1	General structure	120
C.4.2	Frame structure.....	120
C.4.3	Flow of I-frames on layer 2	121
C.4.3.1	Transmission of frames.....	121
C.4.3.2	Reception of frames	121
C.4.3.3	Parameters on layer 2.....	122
C.5	TTCI, Layer 3.....	122
C.5.1	Message structure	122
C.5.2	Definitions of the messages.....	122
C.5.2.1	DATO	122
C.5.2.1.0	Decoded information.....	122
C.5.2.1.1	Test equipment error handling	124
C.5.2.2	Bi-directional operation of the TPCI	124
C.5.2.3	Codec conformance testing.....	125
C.5.2.4	ST indicator	126
C.6	Control of MS/BS.....	126

C.6.0	Options	126
C.6.1	Manual intervention of MS/BS	126
C.6.2	Bi-directional operation of the test interface	126
C.6.3	MS controlled by T1.....	126
C.7	Characteristics of the interface	126
C.7.0	General	126
C.7.1	Mechanical characteristics of the interface.....	126
C.7.2	Electric characteristics of the interface.....	127
C.8	Codec testing using the TTCL.....	127
C.8.0	Options	127
C.8.1	Codec test methodology using the TTCL.....	127
Annex D (normative): RF test facility using RF loop back.....		129
D.0	Definitions	129
D.1	Introduction to the TETRA Test (TT) protocol for RF loop back test.....	130
D.1.0	General	130
D.1.1	Outline requirements	130
D.1.2	Test modes.....	131
D.1.3	Switching for loop back test mode	132
D.2	TETRA test entity	132
D.3	TETRA RF loop back test protocol.....	133
D.3.0	Introduction	133
D.3.1	Setting the TETRA MS into TETRA test mode.....	133
D.3.2	TETRA test protocol	134
D.3.2.0	TETRA Test (TT) protocol discriminator.....	134
D.3.2.1	Confirming that TETRA test mode is set.....	134
D.3.2.2	Operating TETRA loop back.....	135
D.3.2.3	Ending TETRA test mode.....	135
D.3.3	Bad frame indication	136
D.3.4	Channels required to be looped back.....	136
D.3.5	TETRA loop back test scenarios	136
D.4	TETRA Test (TT) PDU descriptions	137
D.4.0	General	137
D.4.1	TT PDU description tables downlink	137
D.4.1.1	D-LOOP COMMAND	137
D.4.1.2	D-OPEN LOOP COMMAND	137
D.4.1.3	D-TEST MODE CONFIRM COMMAND.....	137
D.4.1.4	D-TEST MODE END COMMAND	138
D.4.2	TT PDU description tables uplink.....	138
D.4.2.1	U-LOOP CONFIRM.....	138
D.4.2.2	U-OPEN LOOP CONFIRM	138
D.4.2.3	U-TEST MODE CONFIRM	139
D.4.2.4	U-TEST MODE END CONFIRM.....	139
D.4.3	Information elements coding.....	139
D.4.3.0	General applicability.....	139
D.4.3.1	Loopback type	139
D.4.3.2	Confirm.....	140
D.4.3.3	MS power class.....	140
D.4.3.4	PDU	140
D.4.3.5	Receiver class	141
D.5	TT use of MLE, LLC and MAC.....	141
D.6	Message sequence charts and operation of TETRA loop back	141
D.7	Introduction to the T1 and T4 test modes for RF loop back test.....	142
D.7.0	General	142
D.7.1	Outline requirements	142
D.7.2	T1/T4 Test Modes	142

D.7.3	Switching for loop back test mode	143
D.8	TETRA RF loop back T1 test mode (phase modulation).....	144
D.8.0	Applicability.....	144
D.8.1	Setting TETRA equipment into T1 test mode	144
D.8.2	T1 loop back test mode operation.....	144
D.8.3	Logical channels to be looped back.....	145
D.8.4	Return channel for logical channel loop back	145
D.8.4.0	Return data.....	145
D.8.4.1	Type 1: TCH/7,2 + AACH	146
D.8.4.2	Type 2: SCH/F + AACH	146
D.8.4.3	Type 3: BSCH + SCH/HD + AACH	146
D.8.4.4	Type 4: TCH/2,4 N = 1 + AACH	147
D.8.4.5	Type 7: TCH/7,2 (uplink)	147
D.8.4.6	Type 8: SCH/F (uplink)	147
D.8.4.7	Type 9: STCH + STCH (uplink).....	147
D.8.4.8	Type 10: TCH/2,4 N = 1 (uplink)	148
D.8.4.9	Type 11: SCH/HU + SCH/HU.....	148
D.8.4.10	Type 15: TCH/S + TCH/S + AACH.....	148
D.8.4.11	Type 16: TCH/S + TCH/S (uplink)	148
D.8.4.12	Type 17: TCH/4,8 N = 1 + AACH	149
D.8.4.13	Type 18: TCH/4,8 N = 1 (uplink)	149
D.8.4.14	Type 19: TCH/S speech codec test (downlink).....	149
D.8.4.15	Type 20: TCH/S speech codec test (uplink)	149
D.8.4.16	Type 21: TCH-P8/10,8 (downlink).....	150
D.8.4.17	Type 22: SCH-P8/HD + SCH-P8/HD.....	150
D.8.4.18	Type 24: SCH-P8/F (downlink).....	150
D.8.4.19	Type 21: TCH-P8/10,8 (uplink).....	150
D.8.4.20	Type 24: SCH-P8/F (uplink).....	151
D.8.4.21	Type 23: SCH-P8/HU + SCH-P8/HU.....	151
D.8.5	Loop back test scenarios.....	151
D.9	TETRA RF loop back T4 test mode (QAM).....	153
D.9.0	Applicability.....	153
D.9.1	Setting TETRA equipment into T4 test mode	153
D.9.2	T4 loop back test mode operation.....	154
D.9.3	Logical channels to be looped back.....	154
D.9.4	Return channel for logical channel loop back	155
D.9.4.0	Return data.....	155
D.9.4.1	Type 27: SCH-Q/D with coding rates of 1/2 or 2/3 and error correction enabled	156
D.9.4.2	Type 27: SCH-Q/D with error correction disabled or when the coding rate is 1	156
D.9.4.3	Type 26: SCH-Q/U with coding rates of 1/2 or 2/3 and error correction enabled	157
D.9.4.4	Type 26: SCH-Q/U with coding rate of 1 or error correction disabled.....	158
D.9.4.5	Type 25: SCH-Q/HU with coding rates of 1/2 or 2/3 and error correction enabled	158
D.9.4.6	Type 25: SCH-Q/HU with coding rate of 1 or error correction disabled.....	159
D.9.4.7	Type 28: SCH-Q/RA with error correction enabled	159
D.10	Direct Mode Operation (DMO).....	160
D.10.0	Definitions.....	160
D.10.1	Direct mode only mobile station (DO-MS).....	160
D.10.2	Dual mode switchable mobile station (DU-MS)	160
D.10.3	Dual watch mobile station (DW-MS).....	160
D.10.4	Direct mode repeater (DM-REP).....	160
D.10.5	Direct mode gateway (DM-GATE).....	161
D.10.6	Direct mode repeater/gateway combination (DM-REP/GATE).....	161
D.10.7	DMO summary.....	161
Annex E (normative): Using RF loop back to test a TETRA MS		162
E.0	Applicability.....	162
E.1	Introduction	162
E.2	Expected mode of operation for testing a MS	163

E.3	Recognition of TETRA Test mode by MS.....	166
E.4	Using loop back to test traffic channels	167
E.4.0	Loop back commands.....	167
E.4.1	TCH/7,2.....	169
E.4.2	TCH/S	170
E.4.3	TCH/2,4, N = 8.....	170
E.4.4	Control messages during loop back of traffic channels	171
Annex F (normative): Direct Mode (DM) Testing.....		172
F.1	Scope	172
F.2	Definitions, symbols and abbreviations	172
F.3	General	172
F.4	Radio test modes	172
F.5	Test conditions	173
F.6	Additional tests for equipment which is capable of Direct Mode Operation	174
F.6.1	DMO test transmit mode	174
F.6.2	DMO transmitter output power profile.....	174
F.6.2.1	DMO transmitter output power profile, limit values	174
F.6.2.2	DMO transmitter output power profile, method of measurement.....	174
F.6.3	DMO Carrier frequency accuracy	175
F.6.3.1	DMO Carrier frequency accuracy, limit values	175
F.6.3.2	DMO Carrier frequency accuracy, method of measurement	175
F.6.4	DM-MS Slave synchronization accuracy	175
F.6.4.1	DM-MS Slave synchronization accuracy, definition	175
F.6.4.2	DM-MS Slave synchronization accuracy, limit values	175
F.6.4.3	DM-MS Slave synchronization accuracy, method of measurement	175
Annex G (informative): Change requests.....		177
History		178

Intellectual Property Rights

Essential patents

IPRs essential or potentially essential to normative deliverables may have been declared to ETSI. The information pertaining to these essential IPRs, if any, is publicly available for **ETSI members and non-members**, and can be found in ETSI SR 000 314: "*Intellectual Property Rights (IPRs); Essential, or potentially Essential, IPRs notified to ETSI in respect of ETSI standards*", which is available from the ETSI Secretariat. Latest updates are available on the ETSI Web server (<https://ipr.etsi.org/>).

Pursuant to the ETSI IPR Policy, no investigation, including IPR searches, has been carried out by ETSI. No guarantee can be given as to the existence of other IPRs not referenced in ETSI SR 000 314 (or the updates on the ETSI Web server) which are, or may be, or may become, essential to the present document.

Trademarks

The present document may include trademarks and/or tradenames which are asserted and/or registered by their owners. ETSI claims no ownership of these except for any which are indicated as being the property of ETSI, and conveys no right to use or reproduce any trademark and/or tradename. Mention of those trademarks in the present document does not constitute an endorsement by ETSI of products, services or organizations associated with those trademarks.

Foreword

This Technical Specification (TS) has been produced by ETSI Technical Committee TETRA and Critical Communications Evolution (TCCE).

The present document contains text concerning testing of the equipment to which it relates. This text should be considered only as guidance and does not make the present document mandatory.

The present document is part 1 of a multi-part deliverable covering the testing specification, as identified below:

Part 1: "Radio";

Part 2: "Protocol testing specification for Voice plus Data (V+D)";

Part 4: "Protocol testing specification for Direct Mode Operation (DMO)";

Part 5: "Security".

NOTE: Part 2, part 4 and part 5 of this multi-part deliverable are in status "historical" and are not maintained.

Modal verbs terminology

In the present document "**shall**", "**shall not**", "**should**", "**should not**", "**may**", "**need not**", "**will**", "**will not**", "**can**" and "**cannot**" are to be interpreted as described in clause 3.2 of the [ETSI Drafting Rules](#) (Verbal forms for the expression of provisions).

"**must**" and "**must not**" are **NOT** allowed in ETSI deliverables except when used in direct citation.

Introduction

The present document includes Direct Access and multislot receiver testing in addition to the earlier Release 2 tests and is aligned with ETSI EN 300 392-2 [1].

1 Scope

The present document recommends methods for testing whether TETRA Voice plus Data (V+D) Base Station (BS) and Mobile Station (MS) equipment and TETRA Direct Mode Operation (DMO) equipment achieve the performance specified in ETSI EN 300 392-2 [1]. Specific test methods for DMO equipment are recommended in annex F of the present document. The purpose of these specifications is to provide a sufficient quality of radio transmission and reception for equipment operating in a TETRA system and to minimize harmful interference to other equipment. The present document is applicable to TETRA systems operating at radio frequencies in the range of 137 MHz to 1 GHz.

Versions V3.3.1 [i.5] and earlier of the present document specified the methods used for type testing. The minimum technical characteristics of TETRA Voice plus Data (V+D) Base Station (BS) and Mobile Station (MS) equipment and TETRA Direct Mode Operation (DMO) equipment and radio test methods to be used for providing presumption of conformity, are now specified in ETSI EN 303 758 [i.4].

2 References

2.1 Normative references

References are either specific (identified by date of publication and/or edition number or version number) or non-specific. For specific references, only the cited version applies. For non-specific references, the latest version of the referenced document (including any amendments) applies.

Referenced documents which are not found to be publicly available in the expected location might be found at <https://docbox.etsi.org/Reference/>.

NOTE: While any hyperlinks included in this clause were valid at the time of publication, ETSI cannot guarantee their long term validity.

The following referenced documents are necessary for the application of the present document.

- [1] ETSI EN 300 392-2: "Terrestrial Trunked Radio (TETRA); Voice plus Data (V+D); Part 2: Air Interface (AI)" / ETSI TS 100 392-2: "Terrestrial Trunked Radio (TETRA); Voice plus Data (V+D); Part 2: Air Interface (AI)".

NOTE: The references ETSI EN 300 392-2 and ETSI TS 100 392-2 are two instances of the same document and the latest version of those is used as the normative reference. For a shorter presentation only ETSI EN 300 392-2 is used as the reference in the present document.

- [2] Recommendation ITU-T O.153: "Basic parameters for the measurement of error performance at bit rates below the primary rate".
- [3] ETSI EN 300 113-1: "Electromagnetic compatibility and Radio spectrum Matters (ERM); Land mobile service; Radio equipment intended for the transmission of data (and/or speech) using constant or non-constant envelope modulation and having an antenna connector; Part 1: Technical characteristics and methods of measurement".
- [4] Recommendation ITU-T V.1: "Equivalence between binary notation symbols and the significant conditions of a two-condition code".
- [5] ISO 2110:1989: "Information technology - Data communication - 25-pole DTE/DCE interface connector and contact number assignments".
- [6] ETSI EN 300 395-4: "Terrestrial Trunked Radio (TETRA); Speech codec for full-rate traffic channel; Part 4: Codec conformance testing".
- [7] ETSI EN 300 396-2: "Terrestrial Trunked Radio (TETRA); Technical requirements for Direct Mode Operation (DMO); Part 2: Radio aspects".
- [8] ETSI EN 300 392-1: "Terrestrial Trunked Radio (TETRA); Voice plus Data (V+D); Part 1: General Network Design".

- [9] ETSI EN 300 392-7: "Terrestrial Trunked Radio (TETRA); Voice plus Data (V+D); Part 7: Security".
- [10] ETSI ETS 300 392-11-22: "Terrestrial Trunked Radio (TETRA); Voice plus Data (V+D); Part 11: Supplementary services stage 2; Sub-part 22: Dynamic Group Number Assignment (DGNA)".
- [11] ETSI EN 300 392-12-22: "Terrestrial Trunked Radio (TETRA); Voice plus Data (V+D); Part 12: Supplementary services stage 3; Sub-part 22: Dynamic Group Number Assignment (DGNA)".
- [12] ETSI EN 300 395-2 (V3.3.1): "Terrestrial Trunked Radio (TETRA); Speech codec for full-rate traffic channel; Part 2: TETRA codec".

2.2 Informative references

References are either specific (identified by date of publication and/or edition number or version number) or non-specific. For specific references, only the cited version applies. For non-specific references, the latest version of the referenced document (including any amendments) applies.

NOTE: While any hyperlinks included in this clause were valid at the time of publication, ETSI cannot guarantee their long term validity.

The following referenced documents are not necessary for the application of the present document but they assist the user with regard to a particular subject area.

- [i.1] ETSI ETR 028: "Radio Equipment and Systems (RES); Uncertainties in the measurement of mobile radio equipment characteristics".
- [i.2] ETSI EN 300 396-1: "Terrestrial Trunked Radio (TETRA); Technical requirements for Direct Mode Operation (DMO); Part 1: General network design".
- [i.3] ETSI TS 101 293: "Digital cellular telecommunications system (Phase 2+); Individual equipment type requirements and interworking; Special conformance testing functions (3GPP TS 04.14)".
- [i.4] ETSI EN 303 758: "TETRA radio equipment using non-constant envelope modulation operating in a channel bandwidth of 25 kHz, 50 kHz, 100 kHz or 150 kHz; Harmonised Standard for access to radio spectrum".
- [i.5] ETSI EN 300 394-1 (V3.3.1): "Terrestrial Trunked Radio (TETRA); Conformance testing specification; Part 1: Radio".

3 Definition of terms, symbols and abbreviations

3.1 Terms

For the purposes of the present document, the terms given in ETSI EN 300 392-2 [1] and the following apply:

receive band of the equipment: maximum frequency range (declared by the manufacturer) over which the receiver can be operated without reprogramming or realignment

test facility: organisation with the means and equipment needed to perform tests

transmit band of the equipment: maximum frequency range (declared by the manufacturer) over which the transmitter can be operated without reprogramming or realignment

3.2 Symbols

For the purposes of the present document, the symbols given in ETSI EN 300 392-2 [1] and the following apply:

f_{lo}	local oscillator frequency applied to first receiver mixer
$if_1...if_n$	receiver intermediate frequencies

P_{MS}	access power
P_Q	power level of test QAM burst
E	Stop bit
Message	Information on layer 3

3.3 Abbreviations

For the purposes of the present document, the abbreviations given in ETSI EN 300 392-2 [1] and the following apply:

AACH	Access Assignment CHannel
AACH-Q	Access Assignment CHannel, QAM
AC	Alternating Current
ACCH-Q	Access Assignment CHannel, QAM
AGC	Automatic Gain Control
AI	Air Interface
ASSI	Alias Short Subscriber Identity
BBK	Broadcast BloCk
BCC	Base station Colour Code
BCCH	Broadcast Control CHannel
BER	Bit Error Rate
BFI	Bad Frame Indication
BLCH	Base station Linearization CHannel
BLCH-Q	Base station Linearization CHannel, QAM
BNCH	Broadcast Network CHannel
BNCH/T	Broadcast Network CHannel, Test mode
BSCH	Broadcast Synchronization CHannel
BSCH/T	Broadcast Synchronization CHannel, Test mode
BSCH-Q	Broadcast Synchronization CHannel, QAM
BW	BandWidth
C/I	Carrier to Interference ratio
C/Ia	Carrier to Interference ratio for adjacent channel
C/Ic	Carrier to Interference ratio for co-channel
CA MS	Conventional Access Mobile Station
CA	Conventional Access
CCK	Common Cipher Key
CLCH	Common Linearization CHannel
CLCH-Q	Common Linearization CHannel, QAM
CP	Control Physical channel
CR	Change Request
CRC	Cyclic Redundancy Check
DA MS	Direct Access Mobile Station
DA	Direct Access
DATO	DATa Output
dBc	deciBels relative to carrier power
dBm	deciBels relative to one mW
DC	Direct Current
DGNA	Dynamic Group Number Assignment
DM	Direct Mode
DM-GATE	Direct Mode operation - GATEway
DM-MS	Direct Mode - Mobile Station
DMO	Direct Mode Operation
DM-REP	Direct Mode - REPeater
DM-REP/GATE	Direct Mode - REPeater/GATEway
DNB	Direct mode Normal Burst
DO-MS	Direct mode Only Mobile Station
DQPSK	Differential Quadrature Phase Shift Keying
DSB	Direct Synchronization Burst
DTX	Discontinuous Transmission
DU-MS	DUAl mode Mobile Station
DUT	Device Under Test

DW-MS	Dual Watch - Mobile Station
ETX	End of data
FCB	Frequency Correction downlink Burst
FCS	Frame Check Sequence
FER	Frame Erasure Rate
FN	Frame Number
HTHV	High Temperature High Voltage
HTLV	High Temperature Low Voltage
IE	Information Element
IMM	IMMediate access parameter
ISSI	Individual Short Subscriber Identity
ITSI	Individual TETRA Subscriber Identity
IUT	Implementation Under Test
LCH	Linearization CHannel
LDB	Linearization Downlink Burst
LLC	Logical Link Control
LTHV	Low Temperature High Voltage
LTLV	Low Temperature Low Voltage
LTT-SAP	Service Access Point for TT entity to access Mobile Link Entity (MLE)
MAC	Medium Access Control
MCC	Mobile Country Code
MCCH	Main Control CHannel
MER	Message Erasure Rate
MI	Message Identifier
MIN	Minimum
MLE	Mobile Link Entity
MM	Mobility Management
MMI	Man Machine Interface
MN	Multiframe Number
MNC	Mobile Network Code
MS/BS	MS or BS
OTAR	Over The Air Rekeying
PACQ	Probability of synchronization burst ACQuisition
PCM	Pulse Code Modulation
PDU	Protocol Data Unit
PL	Power Level
PRBS	Pseudo Random Bit Sequence
PUEM	Probability of Undetected Erroneous Message
QAM	Quadrature Amplitude Modulation
RCPC	Rate Compatible Punctured Convolutional
RDC	Radio Downlink Counter
RF	Radio Frequency
RM	Reed-Muller
RMS	Root Mean Square
RMSVE	Root Mean Square Vector Error
RSSI	Received Signal Strength Indicator
Rx	Receiver
SAP	Service Access Point
SB	Synchronization downlink Burst
SCH/F	Signalling CHannel Full
SCH/H	Half-Slot Signalling Channel
SCH/HD	Signalling CHannel, Half size Downlink
SCH/HU	Signalling CHannel, Half size Uplink
SCH/S	Synchronization Channel
SDU	Service Data Unit
SICH	Slot Information CHannel
SICH-Q	Slot Information CHannel, QAM
SIM	Subscriber Identity Module
SNDCP	SubNetwork Dependent Convergence Protocol
SN-Q	Symbol Number in QAM
SS	Supplementary Service
SSI	Short Subscriber Identity

ST	Status indicator
STCH	STealing CHannel
STX	Start of data
TCH	Traffic CHannel
TCH/S	Traffic CHannel, Speech
TD	Timing Delay
TDMA	Time Division Multiple Access
TEDS	TETRA Enhanced Data Service
TEI	TETRA Equipment Identity
TM	TETRA MAC
TM_SDU	TETRA MAC Service Data Unit
TMV-SAP	TETRA MAC Virtual SAP
TN	Timeslot Number
TP	Traffic Physical channel
TSI	TETRA Subscriber Identity
TSS	TETRA System Simulator
TT	TETRA Test
TTCI	TETRA Test Connector Interface
T-TEST	Layer 3 timer (30s) for confirmation of setting of TETRA Test mode
TTL	Transistor-Transistor Logic
TT-SDU	TETRA Test Service Data Unit
Tx	Transmitter
UP	Unallocated Physical channel
USSI	Unexchanged Short Subscriber Identity
V+D	Voice plus Data
WT	Waiting Time

4 General

4.1 Presentation of equipment for testing purposes

4.1.1 Facilities and information required for testing

For testing according to the present document the following facilities are required:

- at least one antenna connector as a test point;
- for equipment supporting diversity, or for any other reason having more than one antenna connector: coupling and/or terminating devices so that the tests can be performed via a single antenna connector;
- if the TETRA equipment does not have an antenna connector: a suitable jig or adapter which allows the conducted tests to be carried out;
- specific test modes, as defined in clause 5.2;
- a test connector which provides decoded data output for all uplink logical channels in the case of BS and downlink logical channels in the case of MS to be tested. The test connector shall also provide any test signalling data. The use of the term "Test Connector" throughout the present document shall mean either a physical connection, as defined in annex C, or a virtual connection by means of an RF Loopback Facility as defined in annex D. The RF Loopback Facility, when used for QAM, may have a certain residual bit error rate due to the peak power limitation. This should be considered when using the RF Loopback Facility as the "Test Connector" for QAM receiver tests;

- for BS equipment a trigger signal which can be used by the test equipment for uplink synchronization. The trigger signal shall be sent once within a multiframe structure and it shall have an arbitrary but fixed relationship (frame, timeslot), defined by the base station manufacturer, to the multiframe structure. The trigger signal shall have TTL level, the timing uncertainty shall be less than $\pm 2,5 \mu\text{s}$ and the rise time and fall time shall each be less than 50 ns;
- a means to connect the equipment to the test power source according to clause 6.

Equipment to be tested according to the present document shall be capable of performing tests using the T1 Test Signal and T4 Test Signal if QAM is supported, whether or not the optional requirements of the RF Loopback Facility are implemented. It is at the discretion of the test facility whether to implement a test system supporting the optional requirements of the RF Loopback Facility.

The following information is required by the test facility:

- power class of equipment;
- receiver class A, B, D or E (MS only);
- other capabilities and options implemented in equipment, including traffic channels supported;
- information related to radio sub-system of equipment, i.e. transmit and receive frequency bands, first local oscillator frequency (f_{lo}) and intermediate frequencies ($if_1 \dots if_n$) of receiver;
- description how to use equipment in specific test modes and test connector interface details;
- information of power source used in equipment.

4.1.2 Choice of radio frequency channels to be tested

The tests described in clauses 8 to 10 shall be performed on one or more frequency channels selected from the lowest 5, the highest 5 and the middle 5 radio frequency channels of either the transmit or receive band of the equipment, whichever is appropriate. The channels required to be tested are defined in clauses 8 to 10 for each individual test.

The use of the terms "lowest radio frequency channel", "highest radio frequency channel" and "middle radio frequency channel" throughout the present document shall mean one of the lowest 5, one of the highest 5 and one of the middle 5 radio frequency channels respectively.

4.1.3 Interpretation of the measurement results

The interpretation of the results recorded in the test report for the measurements described in the present document shall be as follows:

- a) the measured value related to the corresponding limit will be used to decide whether an equipment meets the minimum requirements of the specification in accordance with the shared risk method;
- b) the actual measurement uncertainty of the test facility carrying out the measurement, for each particular measurement, shall be included in the test report;
- c) the values of the actual measurement uncertainty shall be, for each measurement, equal to or lower than the figures given in clause 11. The measurement uncertainty requirements given in the present document corresponds to a confidence level of 95 %, unless otherwise stated. The confidence level is the probability that the true value of the measured parameter lies within the range of values bounded by the uncertainty as described in ETSI ETR 028 [i.1].

This procedure for using maximum acceptable uncertainty values is valid until superseded by other appropriate ETSI publications covering this subject. The use of the measured value has been chosen because there is no definitive standard allowing for measurement uncertainty at the time of publication of the present document. Therefore, the measurement uncertainty shall be used to assess the quality of the actual measurement. The measurement uncertainty values may also be used by the test facility to assess compliance to ETSI standards.

4.2 Mechanical and electrical design

4.2.1 General

The equipment shall be designed, constructed and manufactured in accordance with sound engineering practice and with the aim to minimize harmful interference to other equipment and services.

4.2.2 Controls

Those controls which if maladjusted might increase the interfering potentialities of the equipment shall not be accessible to the user.

4.2.3 Void

5 Radio test configuration, test signals and test modes

5.0 Outline

This clause outlines, in terms of functional blocks, the test system required to perform the radio test procedures and test modes used in clauses 8 to 10.

5.1 General functional radio test configuration

The radio test system configuration shown in figure 5.1 is presented for information only and is not mandatory. The equipment under test shall be connected to the test system via the antenna connector. For the purposes of testing, all TETRA stations shall have at least one antenna connector as specified by the manufacturer.

The base station equipment under test may include, at the discretion of the manufacturer, some optional items if they are necessary to meet the requirements of the present document, such as receiver splitters/low noise amplifiers, transmitter combiners and duplex filtering. In the case of equipment comprising several transmitters, only one transmitter shall be transmitting during all measurements, except for measuring intermodulation attenuation. Depending on the configuration of an equipment the antenna connection may be common for both the transmitter and receiver (at the input to a duplex filter for example) or separate. The equipment shall comply with the present document at the antenna connector specified.

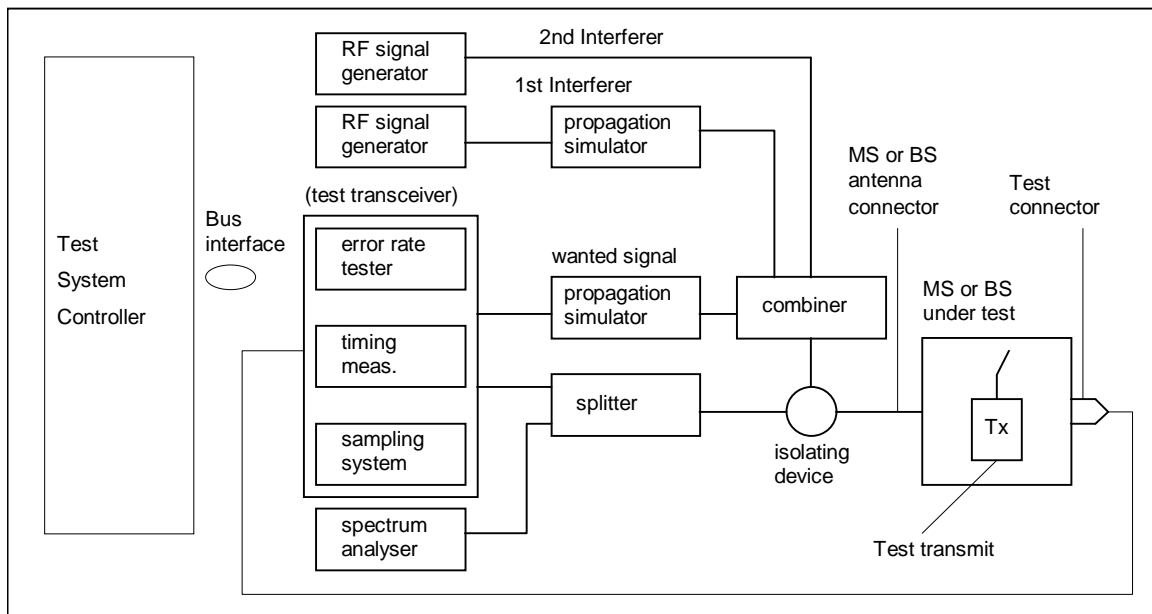

Figure 5.1: Radio test configuration

5.2 Radio test modes

5.2.0 Manufacturer provisions

The manufacturer shall provide the means to operate the equipment under test in either test transmit or test receive modes. The MS under test shall be instructed which test mode to operate in using the Tx_on parameter contained in the BNCH/T and BSCH-Q/T channels of test signal T1 or T4 transmitted by the test system. Further details of test signal T1 and T4 and the contents of BNCH/T and BSCH-Q/T are found in clauses 5.3.2, 5.3.5 and A.3. For a BS under test the manufacturer shall provide the means to configure the BS operation for all tests to be conducted.

5.2.1 Test receive mode

5.2.1.0 Slot width requirements

In test receive mode the equipment shall support one slot wide test data and may support four slots wide test data. Whether one slot or four slots are used for MS receiver testing is defined by the element 'test signal width' in BNCH/T as defined in table A.20 and BSCH-Q/T as defined in table A.21. If four slots test signal is used, then the pseudo random bit sequence continues from one slot to another.

NOTE 1: Configuring to use either one slot or four slots for BS receiver testing is out of scope of the present document.

NOTE 2: When four slots testing is made the test connection TTCI needs to support higher data rate.

NOTE 3: Four slots testing is not compatible with the RF loopback tests.

5.2.1.1 MS test receive mode for phase modulation

The manufacturer shall provide the means to operate the MS under test in MS test receive mode over the frequency range which includes at least the declared V+D downlink RF carrier frequency range and, in the case of an MS with DMO capability, the declared DMO RF carrier frequency range. The receiver of the MS under test shall be set to the same frequency as test signal T1 using the method provided by the manufacturer.

In test receive mode the MS under test shall provide at the test connector a decoded data output for each downlink logical channel (control, traffic) to be tested and for the AACH logical channel received in the same burst. The logical channel type to be decoded is indicated using the T1_T4_burst_type parameter in the BNCH/T.

In all cases whenever the MS decodes a timeslot containing BSCH and BNCH/T the MS shall provide the data decoded from these channels and from the AACH channel received on the same burst at the test connector. In the case where the MS detects an erroneous message on the BSCH or BNCH/T transmitted by the test equipment during frame 18, the MS shall remain in the same state as it was on frames 1 to 17.

5.2.1.2 BS test receive mode for phase modulation

Using the method provided by the manufacturer, the BS in test receive mode shall be configured to receive the desired logical channel type from the test system. The BS shall operate in its normal mode and provide at the test connector the decoded data output of each uplink logical channel tested.

The BS shall be configured to receive the desired logical channel on timeslot 1 of each uplink frame 1 ... 17. During testing the test system shall use the down link BS transmissions to synchronize its uplink burst frequency and timing. The BS may transmit in timeslot 1 of frame 18 a downlink synchronization burst according to table 5.1.

Table 5.1: Base Station down link synchronization burst

Burst type	Block 1	Block 2	Broadcast Block
synchronization	BSCH	BNCH/T	AACH

The downlink synchronization burst contains both BSCH and BNCH/T channels, which includes the T1_T4_burst_type parameter indicating the logical channel the BS is expecting to receive. The BNCH/T is a logical channel specific to the test mode. The contents of the BSCH and BNCH/T channels used during testing are defined in clause A.3. For a BS in continuous mode time slots 1 to 4 of downlink frames 1 to 17 and time slots 2 to 4 of downlink frame 18 are filled with a channel type 1 signal, see clause 5.3.2 for details of channel types. For a BS in discontinuous mode time slot 1 of downlink frames 1 to 17 are filled with a channel type 1 signal.

The values of MCC + MNC + BCC in the BSCH shall form the 30 bits of the extended colour code which is used to generate the scrambling sequence for all downlink and uplink logical channels, except for the BSCH itself where the 30 bits shall be set equal to zero. The test equipment shall use the scrambling sequence indicated by the BS under test.

Unless otherwise specified the following configuration shall be used:

- channel type 1 (see clause 5.3.2 for details);
- the parameters MS_TXPWR_MAX_CELL shall be set to 15 dBm;
- the parameter ACCESS_PARAMETER shall be set to -53 dBm.

The downlink synchronization burst shall be used by the test system to synchronize its uplink sub burst frequency and timing.

In the case of testing a receive-only BS, the manufacturer shall also provide a BS transmitter and the required interconnections with the receive-only BS for synchronization purposes.

5.2.1.3 MS test receive mode for QAM (where supported)

The manufacturer shall provide the means to operate the MS under test in MS QAM test receive mode over the frequency range which includes at least the declared V+D downlink RF carrier frequency. The receiver of the MS under test shall be set to the same frequency and bandwidth as test signal T4 using the method provided by the manufacturer. The MS under test may synchronize to T4 by means of the phase modulation synchronization burst in slot 3 of frame 18 (clause 5.3.5), when testing CA MS performance on a QAM channel. This synchronization burst contains the BSCH and the BNCH/T logical channels.

The MS under test may synchronize to T4 by means of the QAM Frequency Correction Burst (FCB) in slot 1 of frame 18 (clause 5.3.5) when testing DA MS performance on a QAM channel. FCB contains the BSCH-Q/T logical channel.

In test receive mode the MS under test shall provide at the test connector a decoded data output for the downlink payload logical channel to be tested (SCH-Q/D) and for the downlink header logical channels received in the same burst (SICH-Q/D and AACH-Q). The logical channel type to be decoded in the burst payload is indicated using the T1_T4_burst_type parameter in the BNCH/T or BSCH-Q/T. The modulation and code rate information of the payload logical channel is indicated using the QAM_payload_type parameter in the BNCH/T or BSCH-Q/T (i.e. not indicated in SICH-Q/D). The payload logical channel (SCH-Q/D) and the slot information channel (SICH-Q/D) each contain an independent pseudo random bit sequence for testing purposes; the SICH-Q/D therefore does not provide control information to the MS under test.

In the case where the CA MS detects an erroneous message on the BSCH or BNCH/T transmitted by the test equipment during frame 18, slot 3, the MS shall remain in the same state as it was on frames 1 to 17. In the case where the DA MS detects an erroneous message on the BSCH-Q/T transmitted by the test equipment during frame 18, slot 1, the MS shall remain in the same state as it was on frames 1 to 17.

5.2.1.4 BS test receive mode for QAM (where supported)

Using the method provided by the manufacturer, the BS in test receive mode shall be configured to receive the desired logical channel type from the test system. The BS shall operate in its normal mode and provide at the test connector the decoded data output of the uplink payload logical channel to be tested (SCH-Q/U or SCH-Q/HU) and for the uplink header logical channel received in the same burst (SICH-Q/U).

The BS shall be configured to receive the desired logical channel either on timeslot 1 or on all four of each uplink frame 1 ... 17. The BS equipment shall provide a trigger signal which can be used by the test equipment for uplink synchronization (clause 4.1.1).

NOTE 1: Configuring to use either one slot or four slots for BS receiver testing is out of scope of the present document.

Frame 18, slot 1 may contain the BNCH-Q/T channels, which includes the T1_T4_burst_type parameter indicating the logical channel the BS is expecting to receive in the burst payload and the QAM_payload_type parameter indicating the modulation and code rate information the BS is expecting to be used in the received burst payload. The BNCH-Q/T is a logical channel specific to the test mode. The contents of the BNCH-Q/T channels used during testing are defined in clause A.3. Time slots 1 through 4 of downlink frames 1 to 17 and slots 2 through 4 of downlink frame 18 are filled with a channel type 27 signal, see clause 5.3.5 for details of channel types.

NOTE 2: BNCH-Q/T is sent on 25 kHz QAM channel using 4-QAM modulation level with coding rate $r=1/2$. The test equipment will ignore the received SICH-Q, which is scrambled by using the normal scrambling sequence.

The values of MCC + MNC + BCC in the BNCH-Q/T shall form the 30 bits of the extended colour code which is used to generate the scrambling sequence for all downlink and uplink logical channels, except for the BNCH-Q/T itself where the 30 bits shall be set equal to zero. The test equipment shall use the scrambling sequence indicated by the BS under test.

Unless otherwise specified the following configuration shall be used:

- channel type 27 (see clause 5.3.2 for details);
- the parameters MS_TXPWR_MAX_CELL shall be set to 15 dBm;
- the parameter ACCESS_PARAMETER shall be set to -53 dBm.

In the case of testing a receive-only BS, the manufacturer shall also provide a BS transmitter and the required interconnections with the receive-only BS for synchronization purposes.

5.2.2 Test transmit mode

5.2.2.1 MS testing for phase modulation

The manufacturer shall provide the means to operate the MS under test in MS test transmit mode using phase modulation over the frequency range which includes at least the declared V+D uplink RF carrier frequency range and, in the case of an MS with DMO capability, the declared DMO RF carrier frequency range. In test transmit mode, the MS under test may use the Main Carrier, Frequency Band, Offset, Duplex Spacing and Reverse Operation parameters contained in the BNCH/T channel of test signal T1 to set its transmit frequency. If the MS duplex spacing or reverse operation capabilities are fixed, the MS shall ignore these parameters. In test transmit mode the MS under test shall transmit either a normal uplink burst or control uplink burst, as indicated by the Tx_Burst_type parameter of the BNCH/T. The MS shall transmit a $\pi/4$ -DQPSK modulated signal type if the T1_T4_burst_type is a $\pi/4$ -DQPSK modulated signal type. Where supported, a $\pi/8$ -D8PSK modulated signal type shall be used by the MS if the T1_T4_burst_type is a $\pi/8$ -D8PSK modulated signal type. The MS shall be synchronized in time and frequency to the test signal T1 and shall transmit only on timeslot 1.

In test transmit mode the MS shall begin by transmitting a typical CLCH burst on subslot 1 of frame 18 followed by transmission of TCH/7,2 or TCH-P8/10,8 normal uplink bursts on frames 1 to 17, or SCH/HU or SCH-P8/HU control uplink burst on subslot 1 of frames 1 to 17, the sequence then repeating. Further CLCH opportunities are therefore available every multiframe. A bit stream, produced by repeating a pseudo random sequence with a length of 511 bits according to Recommendation ITU-T O.153 [2], shall be used as the information to be transmitted over the logical channel, the sequence then continues across multiframes without breaks after the CLCH slots. The MS shall set its transmit power according to the measured signal strength of signal T1 and the decoded power control parameters in the BNCH/T channel.

In all MS transmitter testing the test system shall continuously transmit test signal T1 with channel type 1 (TCH/7,2) or channel type 21 (TCH-P8/10,8) in timeslot 1 of frames 1 to 17 and synchronization burst containing a BSCH and BNCH/T in timeslot 1 of frame 18. In timeslots 2 to 4 of frames 1 to 18 channel type 0 shall be transmitted.

In test transmission mode the MS shall continue to monitor the BSCH and BNCH/T transmitted by the test equipment on frame 18.

5.2.2.2 Void

5.2.2.3 BS testing for phase modulation

Using the method provided by the manufacturer, the BS in test transmit mode shall be configured to transmit the desired down link logical channel and burst/sub burst type. The BS shall operate in its normal mode e.g. continuous or discontinuous mode. For a BS in discontinuous mode the BS shall transmit only in time slot 1 of each frame. A bit stream, produced by repeating a pseudo random sequence with a length of 511 bits according to Recommendation ITU-T O.153 [2], shall be used as the information to be transmitted over the logical channel. The BS transmission may begin with a BLCH burst and, if required, shall include further BLCH bursts not exceeding one occurrence per four multiframe periods, which shall only occur in block 2 of a Normal Downlink Burst with SCH/HD in block 1 (using Normal Training sequence 2) defined in ETSI EN 300 392-2 [1], clause 9.

The BS shall transmit in timeslot 1 of frame 18, a synchronization burst containing BSCH and BNCH/T information. A BS operating in continuous mode shall transmit a channel type 1 signal in time slots 1 to 4 of frames 1 to 17 and time slots 2 to 4 in frame 18. A BS operating in discontinuous mode shall transmit a channel type 1 signal in timeslot 1 of frames 1 to 17 only.

5.2.2.4 MS testing for QAM (where supported)

The manufacturer shall provide the means to operate the MS under test in MS test transmit mode using QAM over the frequency range which includes at least the declared V+D uplink RF carrier frequency range. The MS under test shall be able to transmit the 8, 16, 32, or 48 subcarrier control up-link burst or normal up-link burst. In test transmit mode, the MS under test may use the Main Carrier, Frequency Band, Offset, Duplex Spacing and Reverse Operation parameters contained in the BNCH/T or BSCH-Q/T channel of test signal T4 to set its transmit frequency. If the MS duplex spacing or reverse operation capabilities are fixed, the MS shall ignore these parameters.

NOTE 1: BNCH/T is used when CA MS performance on a QAM channel is tested. BSCH-Q/T is used when DA MS performance on a QAM channel is tested.

In test transmit mode the MS under test shall transmit either a normal uplink burst or control uplink burst, as indicated by the Tx_Burst_type parameter of the BNCH/T or BSCH-Q/T. The MS shall be synchronized in time and frequency to the test signal T4 and shall transmit only on timeslot 1.

In test transmit mode the MS may begin by transmitting a typical CLCH-Q burst on subslot 1 of uplink timeslots 1 or 3 of frame 18 followed by transmission of SCH-Q/U normal uplink bursts on frames 1 to 17, or SCH-Q/HU control uplink burst on subslot 1 of frames 1 to 17, the sequence then repeating. The SCH-Q/U or SCH-Q/HU logical channel contains K_4 type-4 bits and they are only scrambled as in ETSI EN 300 392-2 [1], clause 8.3.2.5 or clause 8.3.2.4, i.e. only encoding of type-4 bits into type-5 bits is applicable, excluding coding of type-1 bits into type-4 bits. The SICH-Q/U logical channel is encoded normally as in ETSI EN 300 392-2 [1], clause 8.3.2.1, i.e. 5 type-1 bits are encoded into 16 type-5 bits. Further CLCH-Q opportunities are therefore available every multiframe. A bit stream, produced by repeating a pseudo random sequence with a length of 511 bits according to Recommendation ITU-T O.153 [2], shall be used as the information to be transmitted over the logical channel, the sequence then continues across multiframe without breaks after the CLCH-Q slots.

NOTE 2: Continuing the pseudo random bit sequence without breaks from one multiframe to the next is required for randomization of the data patterns across multiple transmitted burst measurements. The 'PRBS continuation' element in the BNCH/T or BSCH-Q/T does not provide control information to the MS in test transmission mode.

The SICH-Q/U logical channel does not provide valid slot information but carries a separate continuous pseudo random bit sequence of length 511 bits which is independent of the bit sequence in the SCH-Q/U or SCH-Q/HU logical channel. The MS shall set its transmit power according to the measured signal strength of signal T4 and the decoded power control parameters in the BNCH/T or BSCH-Q/T channel. The MS shall set its transmit bandwidth and QAM type the same as the received downlink T4 signal according to the 'carrier bandwidth' and 'QAM_payload_type' parameters in the BNCH/T or BSCH-Q/T channel, always transmitting uncoded (only scrambled) regardless of the indication of the downlink rate as 1/2, 2/3 or 1.

NOTE 3: When linearizing the amplifier on the subslot 1 of frame 18, the CA MS is not able to receive and decode the BSCH and BNCH/T and therefore the MS may need to postpone the linearization to the next multiframe. The CA MS may also choose to linearize immediately on subslot 1 of uplink timeslot 3 of frame 18; in this case the CA MS is not able to receive and decode the downlink timeslot 1 of frame 1, but is able to receive and decode the BSCH and BNCH/T.

In all MS transmitter testing the test system shall continuously transmit test signal T4 with channel type 27 (SCH-Q/D) in timeslot 1 of frames 1 to 17 and a synchronization containing a BSCH and BNCH/T, or a BSCH-Q/T, in frame 18 (clause 5.3.5).

In test transmission mode the MS shall continue to monitor the BSCH and BNCH/T, or a BSCH-Q/T, transmitted by the test equipment on frame 18, except when the MS needs to linearize the amplifier and is thus unable to monitor BSCH and BNCH/T, or BSCH-Q/T in the same frame 18.

5.2.2.5 BS testing for QAM (where supported)

Using the method provided by the manufacturer, the BS in test transmit mode shall be configured to transmit the SCH-Q/D logical channel type with 8, 16, 32, or 48 subcarriers and 4-QAM, 16-QAM, or 64-QAM modulation. A bit stream, produced by repeating a pseudo random sequence with a length of 511 bits according to Recommendation ITU-T O.153 [2], shall be used as the information to be transmitted over the logical channel. The pseudo random sequence shall continue without breaks from one multiframe to another.

The BS transmission may begin with a BLCH-Q burst and, if required, shall include further BLCH-Q bursts not exceeding one occurrence per four multiframe periods.

The BS shall transmit in frame 18, slot 1 a BNCH-Q/T logical channel (see clause A.3). The BS equipment shall provide a trigger signal which can be used by the test equipment synchronization (clause 4.1.1). A BS shall transmit a channel type 27 signal in time slots 1 to 4 of frames 1 to 17 and slot 2 to 4 of frame 18.

5.3 Radio test signals

5.3.1 General

In principle the modulation of the test signals T1, to be described below, shall comply with ETSI EN 300 392-2 [1], clause 5. The modulation filter is specified by a set of windowed discrete impulse response samples, $\{g'_j\}$, where $j = 0 \dots N-1$; and

$$g'_j = w_j g \left(TN_s \left(\frac{j}{N-1} - \frac{1}{2} \right) \right)$$

where $g(t)$ is the symbol waveform defined in ETSI EN 300 392-2 [1], clause 5, N_s is the number of symbols spanned by the filter and T is the symbol duration as defined in ETSI EN 300 392-2 [1], clause 5. N_s shall be at least 15. The window coefficients, w_j , are defined by:

$$w_j = 1 - \left(\frac{j - \frac{1}{2}(N-1)}{\frac{1}{2}(N+1)} \right)^2$$

The test transmitter shall be sufficiently linear with respect to amplitude and phase (active linearization should be avoided whenever possible) to meet the requirements in clause B.1.

5.3.2 Test signal T1 (TETRA wanted signal, phase modulation)

5.3.2.0 T1 signal requirements

The T1 signal sequence shall comply with the TETRA air interface multiframe, frame and slot/burst/sub burst structure and is the wanted signal transmitted by the test system during frames 1 to 17 in all receiver tests. The modulation type shall be $\pi/4$ -DQPSK or $\pi/8$ -D8PSK (where supported). The information transmitted by the test system in frame 18 of T1 is used for test control purposes. The slot structure of T1 in frames 1 to 17 is dependent upon the type of receiver test being conducted, defined by the channel type number.

5.3.2.1 MS testing

During MS receiver testing, the test system shall transmit in timeslot 1 of T1 continuous down link burst and channel types according to tables 5.2 and 5.3.

On frame 18 according to table 5.2.

Table 5.2: Test system transmission

Burst type	Block 1	Block 2	Broadcast Block
synchronization	BSCH	BNCH/T	AACH

The BNCH/T is a logical channel specific to the test mode. The contents of the BSCH and BNCH/T to be used during the test are given in clause A.3. The Main Carrier, Frequency Band and Offset parameters contained in the BNCH/T shall indicate the downlink frequency of the T1 test signal being generated. The Duplex Spacing and Reverse Operation parameters contained in the BNCH/T shall indicate the required uplink frequency with respect to the indicated downlink frequency. These parameters are defined in ETSI EN 300 392-2 [1], clause 21.

On frame 1 to 17 one of the following channel types according to table 5.3.

Table 5.3: Channel types

Channel type	Burst type	Block 1	Block 2	Broadcast Block
0	normal	TCH/7,2		AACH
1	normal	TCH/7,2		AACH
2	normal	SCH/F		AACH
3	synchronization	BSCH	SCH/HD	AACH
4	normal	TCH/2,4, N = 1		AACH
21	normal	TCH-P8/10,8		AACH
22	normal	SCH-P8/HD		AACH
24	normal	SCH-P8/F		AACH

The T1 signal shall be scrambled according to ETSI EN 300 392-2 [1], clause 8, using the scrambling sequence generated from the 30 bits of the extended colour code, except for the BSCH where the 30 bits shall be set equal to zero. The extended colour code shall be formed from the values of MCC + MNC + BCC which are transmitted in the T1 signal BSCH information defined in table A.15. The MS under test shall use the scrambling sequence indicated by the T1 signal.

A bit stream, produced by repeating a pseudo random sequence with a length of 511 bits according to Recommendation ITU-T O.153 [2], shall be used as the information to be transmitted over the logical channel to be tested. Unless otherwise specified the contents of any logical channels not currently being tested is undefined. The test system shall support at least one of the pseudo random bit sequence alternatives:

- sequence continues without breaks from one multiframe to another; or
- sequence is repeated for each multiframe starting with frame 1, timeslot 1.

The indication of the sequence type may be defined in BNCH/T, see table A.20.

NOTE: For channel type 3, the logical channels BNCH and STCH have the same coding, interleaving format and performance specification as SCH/HD and are not, therefore, specifically tested.

Channel types 1, 2, 3, 4, 21, 22 and 24 shall be tested in continuous transmission mode where channel type 0 is inserted in time slots 2 to 4 of frames 1 to 18.

For MS synchronization burst acquisition performance testing, the normal multiframe structure shall not be respected and the synchronization continuous downlink bursts (including start and stop bursts) carrying BSCH/T shall be transmitted randomly. The period between the start of two synchronization bursts shall be randomly selected in the range between 800 and 25 000 symbol durations, with a step less than or equal to $\frac{1}{4}$ symbol duration. Nothing shall be transmitted in the time interval between synchronization bursts. This special transmission mode is defined as channel type 13.

5.3.2.2 BS testing

During BS receiver testing the test system shall transmit in timeslot 1 of T1 up link burst and channel types according to tables 5.4 and 5.5.

On frame 18 according to table 5.4.

Table 5.4: Test system transmission

Channel type	Burst type	Block 1	Block 2
8	normal	SCH/F	

On frame 1 to 17 one of the following channel types according to table 5.5.

Table 5.5: Channel types

Channel type	Burst type	Block 1 / Sub slot 1	Block 2 / Sub slot 2
7	normal	TCH/7,2	
8	normal	SCH/F	
9	normal	STCH	STCH
10	normal	TCH/2,4, N = 1	
11	control	SCH/HU	SCH/HU
21	normal	TCH-P8/10,8	
23	normal	SCH-P8/HU	
24	normal	SCH-P8/F	

For BS receiver testing, channel type 7 shall be inserted in time slots 2 to 4 of all uplink frames 1 to 18. A bit stream, produced by repeating a pseudo random sequence with a length of 511 bits according to Recommendation ITU-T O.153 [2], shall be used as the information to be transmitted over the logical channel.

5.3.2.3 Void

5.3.2.4 Void

5.3.3 Test signal T2 (TETRA interferer)

The phase modulated test signal T2 is a $\pi/4$ -DQPSK modulated continuous radio signal following the structure of TETRA signals, but with all modulating bits (including training sequences) derived directly from pseudo random bit sequence (with a length of 511 bits according to Recommendation ITU-T O.153 [2]).

The QAM modulated test signal T2 is a 4-QAM, 16-QAM, or 64-QAM modulated continuous signal with a bandwidth of 25 kHz, 50 kHz, 100 kHz, or 150 kHz following the structure of TEDS signals, but with all modulating symbols' underlying bits (including synchronization and pilot symbols) derived directly from pseudo random bit sequence (with a length of 511 bits according to Recommendation ITU-T O.153 [2]).

T2 is used as an unwanted (modulated) signal.

5.3.4 Test signal T3 (unmodulated interferer)

Test signal T3 is an unmodulated continuous sinusoidal radio signal. T3 is used as an unwanted (unmodulated) signal.

5.3.5 Test signal T4 (TETRA wanted signal, QAM)

5.3.5.0 T4 signal requirements

The T4 signal sequence shall comply with the TETRA air interface multiframe, frame and slot/burst/sub burst structure and is the wanted signal transmitted by the test system during all QAM receiver tests.

The bandwidth of T4 shall be 25 kHz, 50 kHz, 100 kHz, or 150 kHz during QAM modulation, and 25 kHz during $\pi/4$ -DQPSK modulation.

5.3.5.1 MS testing

5.3.5.1.0 Test transmission requirements

The slot structure of T4 for downlink in frames 1 to 17 is that of the normal downlink burst for QAM modulation.

a) CA MS testing

In the case that CA MS performance is tested, $\pi/4$ -DQPSK modulation shall be transmitted in part of frame 18. The $\pi/4$ -DQPSK information transmitted by the test system in frame 18 slot 3 of T4 is used for test control purposes. The structure of the $\pi/4$ -DQPSK transmission in frame 18 is defined in clause 5.3.5.1.1.

During CA MS receiver testing, the test system shall transmit T4 continuous down link burst and channel types according to the tables 5.2 and 5.5b.

On timeslot 3 of frame 18 according to table 5.2.

On frame 1 to 17 one of the channel types according to table 5.5b.

b) DA MS testing

In the case that DA MS performance is tested, QAM modulation shall be transmitted in part of frame 18. The 4-QAM information transmitted by the test system in frame 18 slot 1 of T4 is used for test control purposes. The structure of the QAM transmission in frame 18 is defined in clause 5.3.5.1.1a.

During DA MS receiver testing, the test system shall transmit T4 continuous down link burst and channel types according to the tables 5.5a and 5.5b.

On timeslot 1 of frame 18 according to table 5.5a.

Table 5.5a: Test system transmission

Burst type	Frequency correction data set A	Slot header
frequency correction	BSCH-Q/T	AACH-Q and SICH-Q/D

The BSCH-Q/T is a logical channel specific to the test mode. The contents of the BSCH-Q/T to be used during the test are given in clause A.3. The Main Carrier, Frequency Band and Offset parameters contained in the BSCH-Q/T shall indicate the downlink frequency of the T4 test signal being generated. The Duplex Spacing and Reverse Operation parameters contained in the BSCH-Q/T shall indicate the required uplink frequency with respect to the indicated downlink frequency. These parameters are defined in ETSI EN 300 392-2 [1], clause 21.

On frame 1 to 17 one of the channel types according to table 5.5b.

c) CA and DA MS testing

During both CA MS receiver testing and DA MS receiver testing, the test system shall continuously transmit test signal T4 with channel type 27 (SCH-Q/D) in timeslot 1 of frames 1 to 17, if one slot testing is used, and in timeslots 1 to 4 of frames 1 to 17, if four slots testing is used.

Table 5.5b: Channel types

Channel type	Burst type	Downlink data set	Slot header
27	normal	SCH-Q/D	AACH-Q and SICH-Q/D
27a	normal	SCH-Q/D	AACH-Q and SICH-Q/D

The pseudo random bit sequence continues from one used slot to another. If one slot testing is used, the test system shall continuously transmit test signal T4 with channel type 27a (SCH-Q/D) in timeslots 2 to 4 of frames 1 to 17. Channel type 27a is not intended to be received and decoded by the MS under test; its content is undefined and is independent of the content of channel type 27. The test system shall transmit on frame 18 according to clause 5.3.5.1.1. The T4 signal shall be scrambled according to ETSI EN 300 392-2 [1], clause 8, using the scrambling sequence generated from the 30 bits of the extended colour code, except for the BSCH or BSCH-Q/T where the 30 bits shall be set equal to zero. The extended colour code shall be formed from the values of MCC + MNC + BCC which are transmitted in the T4 signal BSCH information defined in table A.19 or BSCH-Q/T information defined in table A.21. The MS under test shall use the scrambling sequence indicated by the T4 signal.

A bit stream, produced by repeating a pseudo random sequence with a length of 511 bits according to Recommendation ITU-T O.153 [2], shall be used as the information to be transmitted over the logical channel to be tested. The test system shall support at least one of the pseudo random bit sequence alternatives:

- sequence continues without breaks from one multiframe to another; or
- sequence is repeated for each multiframe starting with frame 1, timeslot 1.

The indication of the sequence type may be defined in BNCH/T, see table A.20 and in BSCH-Q/T, see table A.21.

The SICH-Q/D logical channel and the AACH-Q logical channel do not provide valid control information in the T4 test signal: each logical channel carries a separate continuous pseudo random bit sequence of length 511 bits which is independent of the bit sequence in the SCH-Q/D logical channel. Unless otherwise specified the contents of any logical channels not currently being tested is undefined.

NOTE 1: QAM-SLOTINFO has no meaning in the slot header of data stream, which follows the T4 signal. Modulation and code rate information in these slots is indicated by the information element QAM_payload_type in BSCH-Q/T, BNCH-Q/T or BNCH/T channel.

One or four slots may be used for test data, when MS is tested. Whether one slot or four slots are used for testing is defined by the element "test signal width" in BNCH/T as defined in Table A.20 and BSCH-Q/T as defined in table A.21.

NOTE 2: When four slots testing is made the test connection TPCI needs to support higher data rate.

NOTE 3: Four slots testing is not compatible with the RF loopback tests.

5.3.5.1.1 Use of synchronization burst in frame 18 when testing CA MSs

Figure 5.2 illustrates the method in which the test equipment's power, modulation type and RF bandwidth vary with time in the T4 signal.

In figure 5.2, a phase modulation synchronization continuous downlink burst is transmitted during frame 18 slot 3. The QAM signal under test is transmitted during all slots of frames 1 to 17.

The MS under test shall monitor the BNCH/T logical channel transmitted in frame 18 slot 3 in order to detect any changes in the type of test being indicated.

Figure 5.2 shows that frame 17 slot 4 contains a QAM burst transmitted at the RF power level P_Q required for the particular QAM FER and BER measurement in QAM bandwidth f_Q (which may be 25 kHz, 50 kHz, 100 kHz or 150 kHz, according to the test in progress).

Frame 18 slot 1 contains the first two symbols $SN-Q1$ and $SN-Q2$ of a new QAM burst at the same RF power level and RF bandwidth - these contain synchronization pilot symbols and are provided to allow the MS to interpolate back into frame 17 slot 4 for channel estimation purposes.

From just after the symbol time of $SN-Q2$ until 0,5 QAM symbol periods after symbol time $SN-Q4$ the test equipment may ramp its QAM signal down to zero RF level (i.e. from 3 750/9 μ s until 13 125/9 μ s after the start of slot 1). After ramping down the RF output shall then remain at zero power until symbol time $SN133$ of slot 2).

NOTE: A slot starts at symbol times $SN0$ and $SN-Q1$ (ETSI EN 300 392-2 [1], clauses 7.3.2 and 7.5.1).

Frame 18 slot 1 after $SN-Q2$ is used for the QAM frequency correction burst (FCB) when DA MS performance is tested, see clause 5.3.5.1.1a. A CA MS is not required to decode any transmissions it receives in frame 18 slot 1 after $SN-Q2$.

After the symbol time $SN133$ of slot 2 (i.e. 66 500/9 μ s after the start of slot 2), the test equipment shall ramp up and transmit $\pi/4$ -DQPSK symbols. This transmission shall be at the same power as frame 18 slot 3 and may be used by the MS for AGC purposes. The test equipment shall transmit a synchronization continuous down-link burst in slot 3, commencing with the first five symbols of the $\pi/4$ -DQPSK normal training sequence 3 as symbols $SN251$ to $SN255$ of frame 18 slot 2 (slot 2 symbol time $SN251$ occurs 125 500/9 μ s after the start of slot 2).

The synchronization continuous downlink burst sent in slot 3 has the form shown for the T1 test signal in clause 5.3.2.1 for frame 18 slot 1 of the T1 test signal. It contains BSCH in block 1 and BNCH/T in block 2. The synchronization continuous downlink burst includes the $\pi/4$ -DQPSK normal training sequence 3 at the start and end of slot 3. The last six symbols of the $\pi/4$ -DQPSK normal training sequence 3 at the end of slot 3 extend into slot 4, comprising symbols $SN1$ to $SN6$ of slot 4. The $\pi/4$ -DQPSK signalling shall be transmitted in a 25 kHz bandwidth.

The phase modulation transmission shall be aligned so that symbol time $SN0$ for slot 3 occurs $255\,000/9\ \mu\text{s} \pm 125/9\ \mu\text{s}$ after the start of frame 18 slot 1. The centre frequency of the phase modulation transmission shall be the same as the centre frequency of the QAM channel.

The mean power level of the phase modulation transmission should be user-adjustable in the range -115 dBm to -20 dBm. The mean power level of the QAM transmission in frames 1 to 17 may be above or below this level, depending on the type of test.

Transmission of phase modulation stops at the end of the $\pi/4$ -DQPSK normal training sequence 3 that terminates on symbol $SN6$ of frame 18 slot 4 (i.e. at $3\,000/9\ \mu\text{s}$ after the start of slot 4). The phase modulation is ramped down to zero RF power from symbol times $SN6$ until $SN21$ (i.e. from $3\,000/9\ \mu\text{s}$ until $10\,500/9\ \mu\text{s}$ after the start of slot 4).

The phase modulation signal completes its ramp down 0,2 QAM symbol periods ($750/9\ \mu\text{s}$) before symbol time $SN-Q4$ of slot 4 (i.e. at $10\,500/9\ \mu\text{s}$ after the start of slot 4). Starting at symbol time $SN-Q25$ the test generator shall ramp up and transmit QAM symbols. The mean power of this transmission shall be same as in frame 1 slot 1. This transmission may be used by the MS for AGC purposes.

The QAM transmission commencing at $SN-Q25$ of frame 18 slot 4 shall be aligned so that $SN-Q1$ of frame 1 slot 1 occurs at $510\,000/9\ \mu\text{s} \pm 125/9\ \mu\text{s}$ after the start of frame 18 slot 1 and $255\,000/9\ \mu\text{s} \pm 125/9\ \mu\text{s}$ after the symbol time of the $SN0$ symbol that was transmitted in frame 18 slot 3.

The MS under test may use the phase modulation synchronization bursts to obtain initial frequency and time synchronization to an accuracy of $\pm 100\ \text{Hz}$ and $\pm 125/9\ \mu\text{s}$ (1/4 of a phase modulation symbol). It may then maintain this synchronization until frame 1 slot 1, and obtain fine synchronization from the QAM pilot symbols. Normally the MS is expected to maintain QAM synchronization, so it should not be necessary for the MS to resynchronize on subsequent phase modulation bursts.

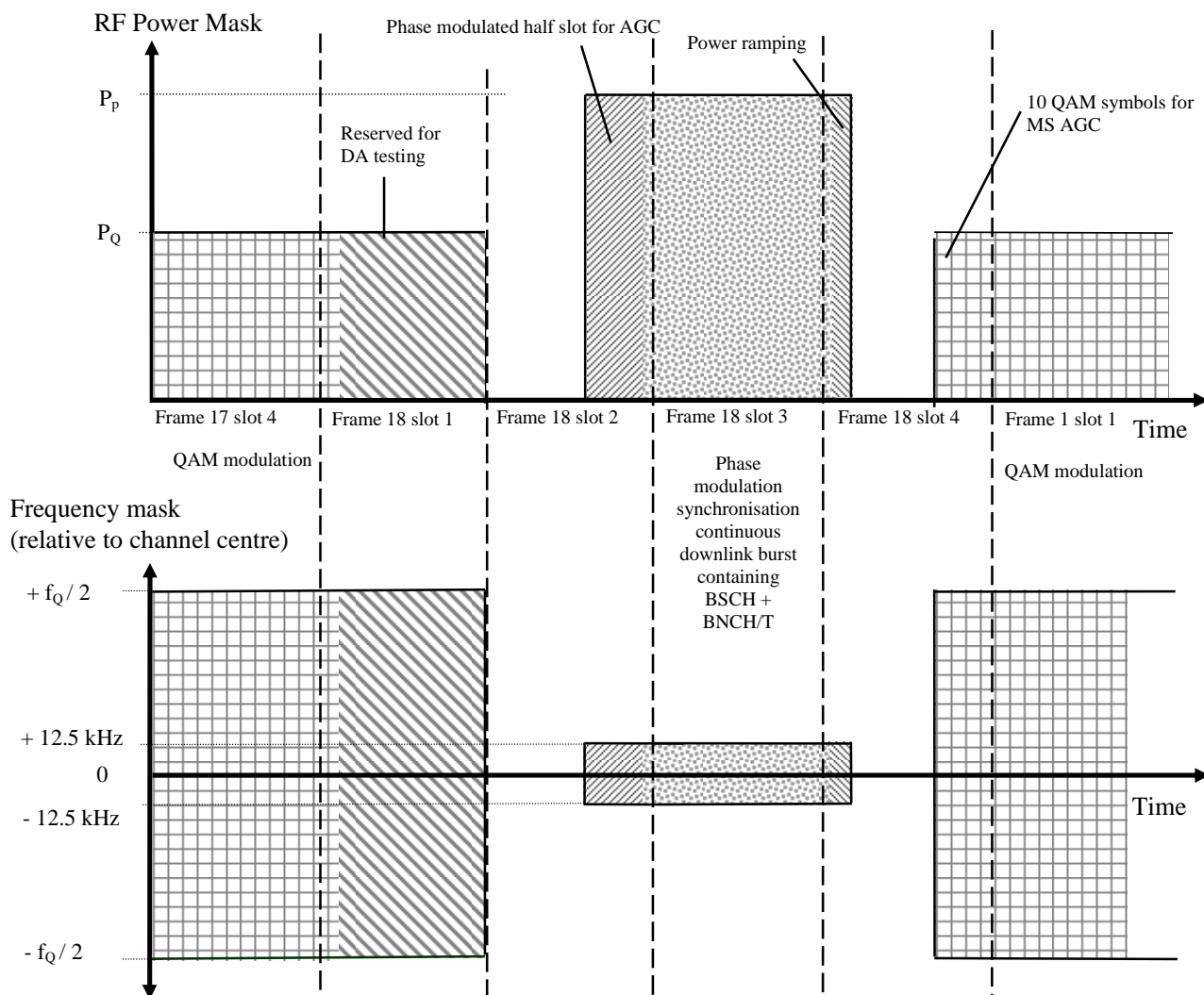

Figure 5.2: Variation of power, modulation type and frequency in a T4 signal for CA testing

5.3.5.1.1a Use of frequency correction burst in frame 18 when testing DA MSs

Figure 5.2a illustrates the method in which the test equipment's power, modulation type and RF bandwidth vary with time in the T4 signal.

In figure 5.2a, a QAM frequency correction burst (FCB) is transmitted during frame 18 slot 1. The QAM signal under test is transmitted during all slots of frames 1 to 17.

The MS under test shall monitor the BSCH-Q/T logical channel transmitted in frame 18 slot 1 in order to detect any changes in the type of test being indicated. In case continuous QAM transmission is used, the slots 2 to 4 in frame 18 include SCH-Q/D without any useful information.

Figure 5.2a shows that frame 17 slot 4 contains a QAM burst transmitted at the RF power level P_Q required for the particular QAM FER and BER measurement in QAM bandwidth f_Q (which may be 25 kHz, 50 kHz, 100 kHz or 150 kHz, according to the test in progress).

The FCB shall be transmitted with the same RF bandwidth, frequency and mean power level as the transmissions in frames 1 to 17.

During the period between symbol time of $SN-Q2$ of slot 2 and 0,5 QAM symbol periods after symbol time $SN-Q4$ of slot 2 (i.e. from $3\ 750/9\ \mu\text{s}$ until $13\ 125/9\ \mu\text{s}$ after the start of slot 2) the QAM transmission may ramp down to zero RF level. The RF output shall then remain at zero power until at least symbol time $SN133$ of slot 2 (i.e. $66\ 500/9\ \mu\text{s}$ after the start of slot 2). Alternatively, the QAM transmission may be continuous over the frame 18.

NOTE 1: A slot starts at symbol times SN_0 and $SN-Q_1$ (ETSI EN 300 392-2 [1], clauses 7.3.2 and 7.5.1).

In frame 18 slot 4 starting at symbol time $SN-Q_{25}$ the test generator shall ramp up (if not already transmitting) and shall transmit QAM symbols. The mean power of this transmission shall be same as in frame 1 slot 1. This transmission may be used by the MS for AGC purposes.

The QAM transmission commencing at $SN-Q_{25}$ of frame 18 slot 4 shall be aligned so that $SN-Q_1$ of frame 1 slot 1 occurs at $510\,000/9\ \mu\text{s} \pm 125/9\ \mu\text{s}$ after the start of frame 18 slot 1.

The MS under test may use the FCB to obtain initial frequency and time synchronization to an accuracy of $\pm 100\ \text{Hz}$ and $\pm 125/9\ \mu\text{s}$. The MS is then expected to maintain QAM synchronization from the QAM pilot symbols in the SCH-Q/D transmissions in frames 1 to 17. It should not be necessary for the MS to resynchronize on subsequent FCBs.

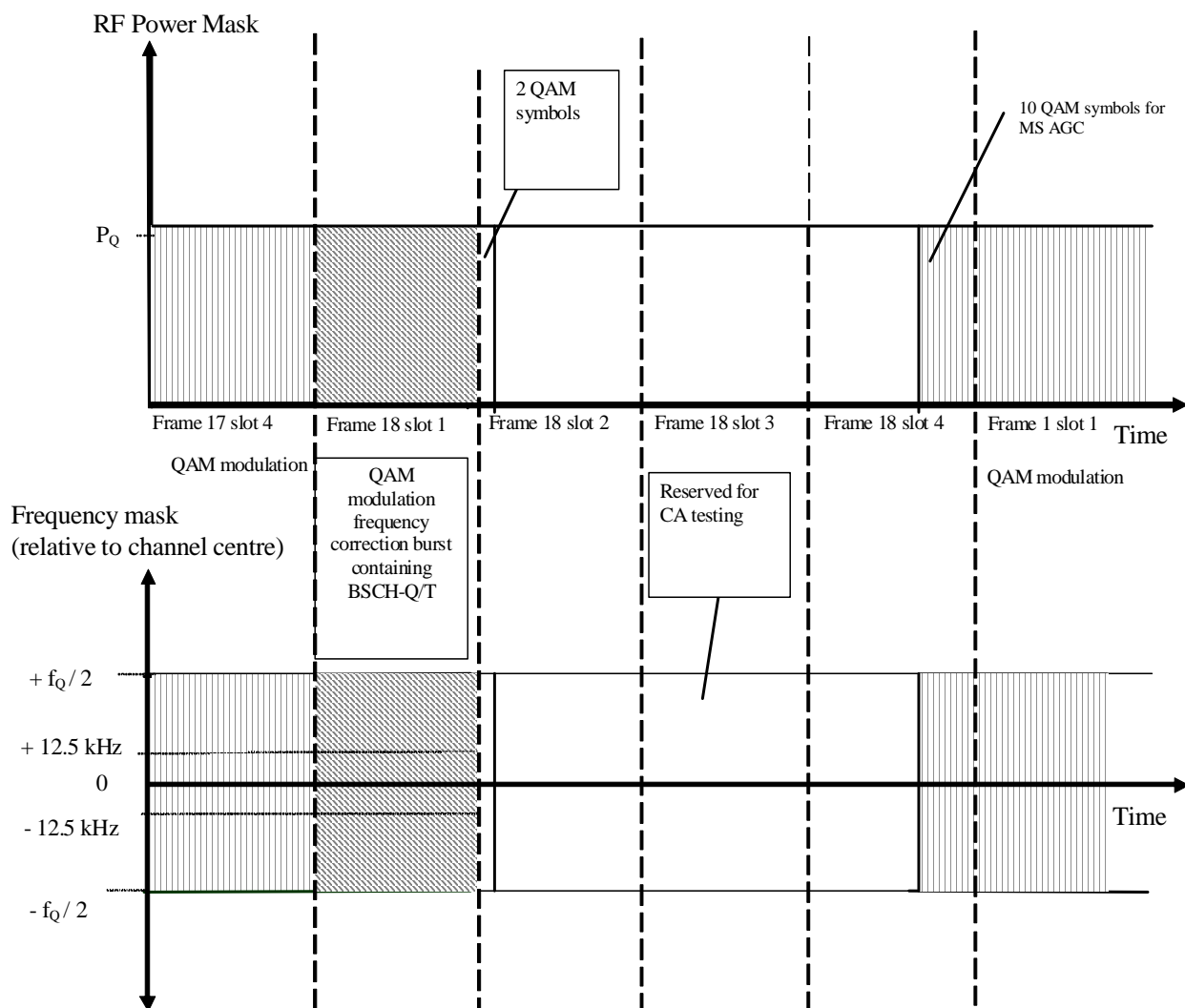

Figure 5.2a: Variation of power, modulation type and frequency in a T4 signal for DA testing

NOTE 2: It is permitted to combine T4 signal in frame 18 slot 1 as described in the figure 5.2 and T4 signal in frame 18 slot 3 as described in the figure 5.2a in a single burst.

5.3.5.2 BS testing

During BS receiver testing the test system shall transmit test signal T4 in uplink timeslot 1, or in case four slots testing is made in all four timeslots, and channel types according to tables 5.6 and 5.7.

On frame 18 according to table 5.6.

Table 5.6: Test system transmission in frame 18

Channel type	Burst type	Sub slot 1	Sub slot 2
26	Normal	SCH-Q/U	

On frame 1 to 17 one of the following channel types according to table 5.7.

Table 5.7: Test system transmission in frames 1 ... 17

Channel type	Burst type	Sub slot 1	Sub slot 2
25	Control	SCH-Q/HU	SCH-Q/HU
26	Normal	SCH-Q/U	

In case channel type 25 is used the data stream is inserted in Sub slot 1 and Sub slot 2.

For BS receiver testing, in case 1 slots testing is made, channel type 26 shall be inserted in time slots 2 to 4 of all uplink frames 1 to 17. A bit stream, produced by repeating a pseudo random sequence with a length of 511 bits according to Recommendation ITU-T O.153 [2], shall be used as the information to be transmitted over the logical channel. The test system shall support at least one of the pseudo random bit sequence alternatives:

- sequence continues without breaks from one multiframe to another; or
- sequence is repeated for each multiframe starting with frame 1, timeslot 1.

NOTE: The selection of the type of pseudo random bit sequence in BS receiver testing is out of scope of the present document.

6 Test conditions

6.1 General

Tests shall be made under normal test conditions and where stated also under extreme test conditions. The test conditions and procedures shall be as specified in clauses 6.2.1 and 6.2.2.

6.2 Power sources and ambient conditions

6.2.0 General

During tests the power source of the equipment shall be replaced by a test power source, capable of producing normal and extreme test voltages as specified in clauses 6.2.1 and 6.2.2. The internal impedance of the test power source shall be low enough for its effect on the test results to be negligible. For the purpose of tests, the voltage of the power source shall be measured at the input terminals of the equipment. If the equipment is provided with a permanently connected power cable, the test voltage shall be that measured at the point of connection of the power cable to the equipment. In equipment with incorporated batteries the test power source shall be applied as close to the battery terminals as practicable. During tests the power source voltages shall be maintained within a tolerance of ± 1 % relative to the voltage at the beginning of each test.

6.2.1 Normal test conditions

The normal temperature and humidity conditions for tests shall be any convenient combination of temperature and humidity within the common range fulfilling all of the following requirements:

- temperature +15 °C to +35 °C (degrees Celsius);
- relative humidity 5 % to 75 %;
- intended operational humidity range of the IUT.

When it is impracticable to carry out the tests under the conditions stated above, the actual temperature and relative humidity during the tests shall be recorded in the test report.

The normal test voltage for equipment to be connected to the mains shall be the nominal mains voltage. For the purpose of these specifications, the nominal voltage shall be the declared voltage or any of the declared voltages for which the equipment was designed. The frequency of the test power source corresponding to the mains shall be between 49 Hz and 51 Hz.

When the radio equipment is intended for operation from the usual types of regulated lead-acid battery power source of vehicles, the normal test voltage shall be 1,1 times the nominal voltage of the battery (6 V, 12 V, etc.).

For operation from other power sources or types of battery (primary or secondary) the normal test voltage shall be that declared by the equipment manufacturer.

6.2.2 Extreme test conditions

For tests on equipment at extreme ambient temperatures measurements shall be made at an upper temperature and a lower temperature defined as follows:

- the lower temperature shall be $-20\text{ }^{\circ}\text{C}$ except for BS equipment where the lowest intended operational temperature of the BS shall apply if this is higher than $-20\text{ }^{\circ}\text{C}$;
- the upper temperature shall be $+55\text{ }^{\circ}\text{C}$ except for BS equipment where the highest intended operational temperature of the BS shall apply if this is lower than $+55\text{ }^{\circ}\text{C}$.

NOTE: The following equipment types are also classified as MS equipment for the purpose of environmental testing: V+D repeater, DM-MS, DW-MS, DM-REP, DM-GATE, DM-REP/GATE.

The extreme humidity conditions shall be the same as the normal humidity conditions specified in clause 6.2.1.

The extreme test voltages for equipment to be connected to an ac mains source shall be the nominal mains voltage $\pm 10\%$.

When the equipment is intended for operation from the usual types of regulated lead-acid battery power sources of vehicles the extreme test voltages shall be 1,3 times and 0,9 times the nominal voltage of the battery (6 V, 12 V, etc.).

The extreme test voltages for equipment with power sources using non regulated batteries shall be as follows. The upper extreme test voltage shall be the normal test voltage. The lower extreme test voltage shall be:

- for the Leclanché, nickel metal hybrid or the lithium-type of battery, 0,85 times the nominal voltage of the battery;
- for the mercury-type or nickel cadmium type of battery, 0,9 times the nominal voltage of the battery;
- for other types of batteries, end point voltage declared by the equipment manufacturer.

However, the lower extreme test source voltages shall be those agreed between the equipment manufacturer and the test facility for the following equipment:

- designed to use other power sources;
- capable of being operated from a variety of power sources;
- designed to include a shut-down facility to ease operation of the equipment at source voltages other than those referred to above.

The conditions shall be recorded in the test report and in the latter case the purpose of including this facility.

The following four extreme test condition combinations are applied while testing TETRA equipment under extreme test conditions:

- LTLV: lower temperature and lower voltage;
- LTHV: lower temperature and higher voltage;

- HTLV: upper temperature and lower voltage;
- HTHV: upper temperature and higher voltage.

Unless otherwise stated tests to be conducted under extreme test conditions shall include all the above temperature and voltage combinations.

6.3 Procedure for tests at extreme temperatures

6.3.0 Thermal balance

Before measurements are made, the equipment shall have reached thermal balance in the test chamber. The equipment shall be switched off during the temperature stabilizing period. In the case of equipment containing temperature stabilization circuits designed to operate continuously, the temperature stabilization circuits may be switched on for 15 minutes after thermal balance has been obtained, the equipment shall then meet the specified requirements. If the thermal balance is not checked by measurements, a temperature stabilizing period of at least one hour, or such period as may be decided by the test facility shall be allowed. The sequence of measurements shall be chosen, and the humidity content in the test chamber shall be controlled so that excessive condensation does not occur.

6.3.1 Equipment designed for continuous operation

Before tests at the upper temperature, the equipment shall be placed in the test chamber and left until thermal balance is attained. The equipment shall then be switched on in the transmit state for a period of 30 minutes after which the equipment shall meet the specified requirements.

Before tests at the lower temperature, the equipment shall be left in the test chamber until thermal balance is attained, then switched to the idle (non-transmit) state for a period of 4 minutes, after which the equipment shall meet the specified requirements.

6.3.2 Equipment designed for intermittent operation

Before tests at the upper temperature, the equipment shall be placed in the test chamber and left until thermal balance is attained. The equipment shall then be switched on in the idle (non-transmit) state for a period of four minutes prior to testing. In the case of transmitter CLCH testing, measurement of unwanted emissions shall take place immediately following this period. Prior to further transmitter testing the equipment shall be operated in the transmit state for a period of one minute followed by four minutes in the idle (non-transmit) state before measurements are made.

Before tests at the lower temperature, the equipment shall be left in the test chamber until thermal balance is attained, then switched to the idle (non-transmit) state for a period of one minute after which the equipment shall meet the specified requirements.

7 Technical characteristics

7.1 Transmitter parameter definitions and limits

7.1.1 Transmitter output power

7.1.1.1 Definition

Power for phase modulation is defined as the average power, measured through TETRA filter, refer to clause B.1.2.2 defined in ETSI EN 300 392-2 [1], clause 5.5, over the useful part of the burst as defined in ETSI EN 300 392-2 [1], clause 9.

Power for QAM is defined as the sum of the powers of each of the sub-carriers within the RF channel bandwidth. For each sub-carrier, reference power is defined as the average power, measured at symbol time through the square root raised cosine filter defined in ETSI EN 300 392-2 [1], clause 5.16, over the pilot and sync symbols within the QAM burst as defined in ETSI EN 300 392-2 [1], clause 9.

For a bursted transmission, power for QAM and phase modulation is further defined by transmitter output power versus time.

7.1.1.2 Limit values for phase modulation and QAM

The following requirements shall be met:

- a) The average transmitter output power measured under the normal test conditions shall be within $\pm 2,0$ dB of the nominal value specified for the BS or MS power class in ETSI EN 300 392-2 [1], clause 6. Under extreme test conditions the average transmitter output power shall be within $+3,0$ dB and $-4,0$ dB of nominal. The average transmitter output power under normal test conditions of the MS at all power control levels below its nominal power class shall be within $\pm 2,5$ dB of the MS power control levels in ETSI EN 300 392-2 [1], clause 6. The difference in level between adjacent power control levels shall be $5,0$ dB $\pm 2,5$ dB ($2,5$ dB $\pm 2,5$ dB for the first step for mobiles with power class modifier L). The average transmitter output power at the minimum power level under extreme test conditions shall be within $\pm 4,0$ dB of the minimum MS power control level in ETSI EN 300 392-2 [1], clause 6.
- b) For an MS or discontinuous BS with phase modulation, the transmitter output power versus time shall be within the power time mask specified in ETSI EN 300 392-2 [1], clause 6, figure 6.3, measured through the TETRA filter, refer to clause B.1.2.2, under normal and extreme test conditions. The time periods t_1 , t_2 and t_3 in ETSI EN 300 392-2 [1], clause 6, figure 6.3 are defined in ETSI EN 300 392-2 [1], clause 6, table 6.8, and in ETSI EN 300 392-2 [1], annex O, figure O.4 and table O.2 for the air to ground service.
- c) For an MS with QAM modulation, the transmitter output power versus time shall be within the power time mask specified in ETSI EN 300 392-2 [1], clause 6, figure 6.4, measured under normal and extreme test conditions. The time periods t_1 , t_2 and t_3 in ETSI EN 300 392-2 [1], clause 6, figure 6.4 are defined in ETSI EN 300 392-2 [1], clause 6, table 6.20.

For BS in discontinuous mode $L_{min} = -40$ dBc and for MS $L_{min} = -70$ dBc.

In any case, no requirement less than -36 dBm shall apply i.e. the maximum power level need not be less than -36 dBm.

7.1.2 Unwanted output power in non-active transmit state

7.1.2.1 Definition

The unwanted output power in non-active transmit state is the average power emitted by a BS operating in discontinuous mode or MS transmitter, as measured through the TETRA filter, refer to clause B.1.2.2, over the non active period of non active timeslots occurring between successive burst transmissions. The non-active period excludes the time periods t_1 and t_3 of active timeslots, defined in ETSI EN 300 392-2 [1], clause 6 table 6.8, and in ETSI EN 300 392-2 [1], annex O, figure O.4 and table O.2 for the air to ground service.

7.1.2.2 Limit values

The unwanted output power in non active transmit state shall not exceed for a BS -40 dBc or MS -70 dBc under normal test conditions. In any case, no requirement less than -36 dBm shall apply i.e. the maximum power level need not be less than -36 dBm.

NOTE: 0 dBc refers to the BS or MS transmit power.

7.1.3 Adjacent channel power due to modulation

7.1.3.1 Definition

The adjacent channel power due to modulation is the average power over the useful part of a burst, as measured through the TETRA filter, refer to clause B.1.2.2, emitted by an active BS or MS transmitter at the frequency offsets specified from the nominal centre frequency of the allocated channel.

7.1.3.2 Limit values for phase modulation

The limit values given in tables 7.1 to 7.3 shall not be exceeded at the listed frequency offsets from the nominal carrier frequency. For frequencies below 700 MHz, tables 7.1 and 7.2 apply. For frequencies above 700 MHz, table 7.3 applies.

Table 7.1: Maximum adjacent channel power levels for MS power classes 4 and 4L

Frequency offset	Maximum level (normal test conditions)	Maximum level (extreme test conditions)
25 kHz	-55 dBc	-45 dBc
50 kHz	-70 dBc	-60 dBc
75 kHz	-70 dBc	-60 dBc

Table 7.2: Maximum adjacent channel power levels for other power classes

Frequency offset	Maximum level (normal test conditions)	Maximum level (extreme test conditions)
25 kHz	-60 dBc	-50 dBc
50 kHz	-70 dBc	-60 dBc
75 kHz	-70 dBc	-60 dBc

Table 7.3: Maximum adjacent channel power levels for frequencies above 700 MHz

Frequency offset	Maximum level (normal test conditions)	Maximum level (extreme test conditions)
25 kHz	-55 dBc	-45 dBc
50 kHz	-65 dBc	-55 dBc
75 kHz	-65 dBc (note 1)	-55 dBc (note 2)
NOTE 1: A level of -70 dBc shall apply for BS Power Classes 1, 2 and 3 and for MS Power Classes 1 and 1L.		
NOTE 2: A level of -60 dBc shall apply for BS Power Classes 1, 2 and 3 and for MS Power Classes 1 and 1L.		

These requirements shall be measured under normal and extreme test conditions. In any case, no requirement less than -36 dBm shall apply i.e. the maximum power level need not be less than -36 dBm.

NOTE: 0 dBc refers to the BS or MS transmit power.

The levels given in ETSI EN 300 392-2 [1], tables 6.4 and 6.5 shall not be exceeded at the listed frequency offsets from the nominal carrier frequency.

7.1.3.3 Limit values for QAM

The levels given in tables 7.4, 7.5, 7.6 and 7.7 shall not be exceeded at the listed frequency offsets from the nominal carrier frequency.

Table 7.4: Maximum adjacent power levels for 25 kHz QAM

Frequency offset	Maximum level for MS and BS
25 kHz	-55 dBc
50 kHz	-65 dBc
75 kHz	-67 dBc

Table 7.5: Maximum adjacent power levels for 50 kHz QAM

Frequency offset	Maximum level for MS and BS
37,5 kHz	-55 dBc
62,5 kHz	-63 dBc
87,5 kHz	-65 dBc

Table 7.6: Maximum adjacent power levels for 100 kHz QAM

Frequency offset	Maximum level for MS and BS
62,5 kHz	-55 dBc
87,5 kHz	-60 dBc
112,5 kHz	-60 dBc

Table 7.7: Maximum adjacent power levels for 150 kHz QAM

Frequency offset	Maximum level for MS and BS
87,5 kHz	-55 dBc
112,5 kHz	-60 dBc
137,5 kHz	-60 dBc

For extreme test conditions, add 10 dB to the maximum level. These requirements shall be measured under normal and extreme test conditions. In any case, no requirement less than -36 dBm shall apply i.e. the maximum power level need not be less than -36 dBm.

7.1.4 Adjacent channel power due to switching transients

7.1.4.1 Definition

The adjacent channel power due to switching transients is the peak power over the ramp-up and ramp-down periods of a burst, as measured through the TETRA filter, refer to clause B.1.2.2, emitted by an active BS transmitter operating in discontinuous mode or an active MS transmitter at frequency offsets specified from the nominal frequency of the allocated channel.

7.1.4.2 Limit values for phase modulation

The adjacent channel peak power level, at a frequency offset of 25 kHz, shall not exceed -45 dBc for MS Power Classes 4 and 4L and -50 dBc for other Power Classes. In any case, no requirement less than -36 dBm shall apply i.e. the maximum power level need not be less than -36 dBm.

This requirement shall be measured under normal test conditions.

NOTE: 0 dBc refers to the BS or MS transmit power.

7.1.4.3 Limit values for QAM

For 25 kHz QAM the maximum hold level of -45 dBc at a frequency offset of 25 kHz shall not be exceeded.

For 50 kHz QAM the maximum hold level of -45 dBc at a frequency offset of 37,5 kHz shall not be exceeded.

For 100 kHz QAM the maximum hold level of -45 dBc at a frequency offset of 62,5 kHz shall not be exceeded.

For 150 kHz QAM the maximum hold level of -45 dBc at a frequency offset of 87,5 kHz shall not be exceeded.

This requirement does not apply to linearization channels.

In any case, no requirement less than -36 dBm shall apply i.e. the maximum power level need not be less than -36 dBm.

This requirement shall be measured under normal test conditions.

NOTE: 0 dBc refers to the BS or MS transmit power.

7.1.5 Unwanted emissions far from the carrier

7.1.5.1 Definition

These unwanted emissions are emissions (discrete, wide-band noise, modulated or unmodulated) occurring at offsets equal or greater than 100 kHz from the carrier frequency, measured in the frequency range 9 kHz to 4 GHz (9 kHz to 12,75 GHz for equipment capable of operating at frequencies above 470 MHz).

7.1.5.2 Limit values for phase modulation

Discrete Spurious:

The maximum allowed power for each spurious emission shall be less than -36 dBm measured in 100 kHz bandwidth in the frequency range 9 kHz to 1 GHz and -30 dBm measured in 1 MHz bandwidth in the frequency range 1 GHz to 4 GHz (1 GHz to 12,75 GHz for equipment capable of operating at frequencies above 470 MHz). Specific measurement methods and lower bandwidths (as defined in table 8.2) are required both when measuring within $\pm f_{rb}$ of carrier frequency, due to the presence of wideband noise, and in the lower part of the spectrum.

Wideband noise:

The following wideband noise levels measured through the TETRA filter, refer to clause B.1.2.2, shall not exceed the limits shown in tables 7.8 and 7.9 for the power classes as stated and at the listed offsets from the nominal carrier frequency. The requirements apply symmetrically to both sides of the transmitter band.

Table 7.8: Wideband noise limits for frequencies below 700 MHz

Frequency offset	Maximum wideband noise level		
	MS Nominal power level \leq PL 4 (1 W)	MS Nominal power level = PL 3 (3 W) or PL 3L (1,8 W)	MS Nominal power level \geq PL 2L (5,6 W) BS (all classes)
100 kHz to 250 kHz	-75 dBc	-78 dBc	-80 dBc
250 kHz to 500 kHz	-80 dBc	-83 dBc	-85 dBc
500 kHz to f_{rb}	-80 dBc	-85 dBc	-90 dBc
$> f_{rb}$	-100 dBc	-100 dBc	-100 dBc

NOTE: f_{rb} denotes the frequency offset corresponding to the near edge of the received band or 5 MHz (10 MHz for frequencies above 520 MHz) whichever is greater. All levels are expressed in dBc relative to the actual transmitted power level, and in any case no limit tighter than -55 dBm for offsets $\leq f_{rb}$ or -70 dBm for offsets $> f_{rb}$ shall apply.

Table 7.9: Wideband noise limits for frequencies above 700 MHz

Frequency offset	Maximum wideband noise level		
	MS Nominal power level ≤ PL 4 (1 W)	MS Nominal power levels from 1,8 W to 10 W and BS Nominal power levels ≤ 10 W	MS and BS Nominal power levels from 15 W to 40 W
100 kHz to 250 kHz	-74 dBc	-74 dBc	-80 dBc
250 kHz to 500 kHz	-80 dBc	-80 dBc	-85 dBc
500 kHz to f_{rb}	-80 dBc	-85 dBc	-90 dBc
> f_{rb}	-100 dBc	-100 dBc	-100 dBc

NOTE: f_{rb} denotes the frequency offset corresponding to the near edge of the received band or 10 MHz whichever is greater. All levels are expressed in dBc relative to the actual transmitted power level, and in any case no limit tighter than -55 dBm for offsets ≤ f_{rb} or -70 dBm for offsets > f_{rb} shall apply.

These requirements shall be measured under normal conditions.

7.1.5.3 Limit values for QAM

Discrete Spurious:

These limits are the same as phase modulation.

Wideband noise:

The wideband noise levels, measured through the modulation filter defined in clause 5.6 of ETSI EN 300 392-2 [1], should not exceed the limits shown in the tables 7.10 to 7.13, for the nominal power levels as stated, and at the listed offsets from the nominal carrier frequency. When applicable, relative measurements (dBc) shall refer to the power level measured at the nominal centre frequency as defined in clause 6.4.8 of ETSI EN 300 392-2 [1]. The requirements apply symmetrically to both sides of the transmitter band.

Table 7.10: Wideband noise limits 25 kHz QAM

Frequency offset	Maximum wideband noise level for MS and BS	
	MS nominal power level ≤ 3 W (class 3)	MS nominal power level ≥ 5,6 W (class 2L) BS all classes
100 kHz to 250 kHz	-70 dBc	-70 dBc
250 kHz to 500 kHz	-74 dBc	-80 dBc
500 kHz to 2 500 kHz	-80 dBc	-80 dBc
2 500 kHz to f_{rb}	-80 dBc	-90 dBc
> f_{rb}	-95 dBc	-95 dBc

NOTE: f_{rb} denotes the frequency offset corresponding to the near edge of the receive band or 5 MHz (10 MHz for frequencies above 520 MHz) whichever is greater.

Table 7.11: Wideband noise limits 50 kHz QAM

Frequency offset	Maximum wideband noise level for MS and BS	
	MS nominal power level ≤ 3 W (class 3)	MS nominal power level ≥ 5,6 W (class 2L) BS all classes
112,5 kHz to 262,5 kHz	-68 dBc	-70 dBc
262,5 kHz to 500 kHz	-72 dBc	-75 dBc
500 kHz to f_{rb}	-78 dBc	-80 dBc
> f_{rb}	-95 dBc	-95 dBc

NOTE: f_{rb} denotes the frequency offset corresponding to the near edge of the receive band or 5 MHz (10 MHz for frequencies above 520 MHz) whichever is greater.

Table 7.12: Wideband noise limits 100 kHz QAM

Frequency offset	Maximum wideband noise level for MS and BS	
	MS nominal power level ≤ 3 W (class 3)	MS nominal power level $\geq 5,6$ W (class 2L) BS all classes
137,5 kHz to 287,5 kHz	-60 dBc	-70 dBc
287,5 kHz to 537,5 kHz	-65 dBc	-70 dBc
537,5 kHz to 1 000 kHz	-73 dBc	-75 dBc
1 000 kHz to f_{rb}	-73 dBc	-80 dBc
$> f_{rb}$	-95 dBc	-95 dBc

NOTE: f_{rb} denotes the frequency offset corresponding to the near edge of the receive band or 5 MHz (10 MHz for frequencies above 520 MHz) whichever is greater.

Table 7.13: Wideband noise limits 150 kHz QAM

Frequency offset	Maximum wideband noise level for MS and BS	
	MS nominal power level ≤ 3 W (class 3)	MS nominal power level $\geq 5,6$ W (class 2L) BS all classes
162,5 kHz to 312,5 kHz	-60 dBc	-60 dBc
312,5 kHz to 562,5 kHz	-63 dBc	-70 dBc
562,5 kHz to 1 500 kHz	-70 dBc	-75 dBc
1 500 kHz to f_{rb}	-70 dBc	-80 dBc
$> f_{rb}$	-95 dBc	-95 dBc

NOTE: f_{rb} denotes the frequency offset corresponding to the near edge of the receive band or 5 MHz (10 MHz for frequencies above 520 MHz) whichever is greater.

All levels in the tables are expressed in dBc relative to the actual transmitted power level, and in any case no limit tighter than -55 dBm for offsets $< f_{rb}$ or -70 dBm for offsets $> f_{rb}$ shall apply.

These requirements shall be measured under normal conditions.

7.1.6 Unwanted radiated emissions

7.1.6.1 Definition

Unwanted radiated emissions are emissions (whether modulated or unmodulated) radiated by the cabinet and structure of the equipment (MS or BS). This is also known as cabinet radiation.

7.1.6.2 Limit values

The limits given in clauses 7.1.5.2 (phase modulation) and 7.1.5.3 (QAM modulation) shall apply for frequencies between 30 MHz and 4 GHz only.

7.1.7 Unwanted emissions during the BLCH/CLCH (linearization)

7.1.7.1 Definition

These unwanted emissions are emissions produced by a BS or MS, measured through a TETRA filter, refer to clause B.1.2.2, at the specified frequency offset from the nominal carrier frequency, while the BS is transmitting a linearization burst on the BS Linearization Channel (BLCH) or a MS transmitting a linearization burst on the Common Linearization Channel (CLCH).

7.1.7.2 Limit values for phase modulation

The sum of the time periods during which the peak power, at a frequency offset of ± 25 kHz during the BLCH/CLCH, is above -45 dBc shall not exceed 1 ms. This peak power shall never exceed -30 dBc.

NOTE: 0 dBc refers to the transmit power during normal operation after the BLCH/CLCH.

These requirements shall be measured under normal and extreme test conditions.

7.1.7.3 Limit values for QAM

For 25 kHz QAM the sum of the time periods during which the peak power, at a frequency offset of ± 25 kHz during the BLCH-Q/CLCH-Q, is above -45 dBc shall not exceed 1 ms. This peak power shall never exceed -30 dBc.

For 50 kHz QAM the sum of the time periods during which the peak power, at a frequency offset of $\pm 37,5$ kHz during the BLCH-Q/CLCH-Q, is above -45 dBc shall not exceed 1 ms. This peak power shall never exceed -30 dBc.

For 100 kHz QAM the sum of the time periods during which the peak power, at a frequency offset of $\pm 62,5$ kHz during the BLCH-Q/CLCH-Q, is above -45 dBc shall not exceed 1 ms. This peak power shall never exceed -30 dBc.

For 150 kHz QAM the sum of the time periods during which the peak power, at a frequency offset of $\pm 87,5$ kHz during the BLCH-Q/CLCH-Q, is above -43 dBc shall not exceed 1 ms. This peak power shall never exceed -30 dBc.

NOTE: 0 dBc refers to the transmit power during normal operation after the CLCH-Q or BLCH-Q.

These requirements shall be measured under normal and extreme test conditions.

7.1.8 Transmitter intermodulation attenuation

7.1.8.1 Definition

Transmitter intermodulation attenuation is the ratio of the power level of the wanted signal to the power level of an intermodulation component. It is a measure of the capability of the transmitter to inhibit the generation of signals in its non-linear elements caused by the presence of the useful carrier and an interfering signal reaching the transmitter via its antenna.

7.1.8.2 Limit values for phase modulation and QAM

7.1.8.2.1 MS Limit values

For an MS transmitter operating at the nominal power defined by its class, the intermodulation attenuation shall be at least 60 dB for any intermodulation component when measured in 30 kHz bandwidth. The interfering signal shall be unmodulated and have a frequency offset of at least 500 kHz from the carrier frequency. The power level of the interfering signal shall be 50 dB below the level of the modulated output signal from the transmitter under test.

This requirement shall be measured under normal test conditions.

7.1.8.2.2 Limit values for single BS transmitter

The intermodulation attenuation of the base station equipment shall be at least 70 dB for any intermodulation component when measured in 30 kHz bandwidth. However, in the case of base station equipment with only one transmitter and which is not intended to be collocated with other radio transmitting equipment, an intermodulation attenuation of at least 40 dB shall be sufficient. The interfering signal shall be unmodulated and have a frequency offset of at least 500 kHz from the carrier frequency. The power level of the interfering signal shall be 30 dB below the power level of the modulated output signal from the transmitter under test.

If the intermodulation attenuation is achieved by additional, internal or external, isolating devices they shall be included in the measurements.

In any case, no requirement less than -36 dBm shall apply i.e. the maximum power level need not be less than -36 dBm.

All power levels stated in the cases above are referring to the antenna connector of the base station.

These requirements shall be measured under normal test conditions.

7.1.8.2.3 Limit values for intra BS intermodulation

In a BS, intermodulation may be caused by combining several transmitters and carriers to feed a single antenna.

For all transmitters of a single TETRA base station, the power of any intermodulation components, when measured in a 30 kHz bandwidth, shall not exceed -60 dBc in the relevant downlink frequency band. In any case, no requirement less than -36 dBm shall apply i.e. the maximum power level need not be less than -36 dBm.

NOTE: The value of -60 dBc refers to the carrier power of the transmitter with the highest power output, measured at the antenna connector of the base station.

In the case where the performance is achieved by additional, internal or external isolating devices (such as circulators) they shall be supplied at the time of testing and shall be used for measurements. The frequencies of the individual transmitters used during testing shall be stated in the test report.

This requirement shall be measured under normal test conditions.

7.2 Receiver parameter definitions and limits

7.2.1 General

The required minimum number of samples (bits in the case of BER measurements and messages in the case of MER and PUEM measurements) and the test limit error rates used in the following receiver tests have been defined such that:

- a) the probability of passing a bad unit is lower than 0,3 %;
- b) the probability of passing a good unit, operating on the limit of performance, is at least 99,5 %.

A unit shall be considered bad if its true BER/MER performance is worse than 1,5 times the specified BER/MER in static conditions and worse than 1,26 times the specified BER/MER in dynamic (fading multipath) conditions. These values have been adopted (taking into account the expected shapes of the BER/MER performance) in order to not to pass a unit with a sensitivity or interference rejection performance, 1 dB worse than that of a unit which just meets the specification.

NOTE: The above definition of a bad unit does not apply to PUEM measurements.

Using at least the minimum number of samples shown in the tables of clause A.2, the MS or BS shall not exceed the test limits shown in the tables of clause A.2. These test limits (with the exception of PUEM measurements) are 1,22 times worse than the specified performance in static conditions, and 1,12 times worse than the specified performance in dynamic conditions, corresponding to a performance 0,5 dB worse than that specified. These values satisfy the requirements of a) and b) above. It is permitted to run the test over more samples than the value stated for minimum number of samples. The effect of increasing the number of samples is always to give a higher probability that a good unit will pass and a lower risk that a bad unit will pass, according to the definitions of good and bad unit in this clause.

All signal levels are referenced to the antenna connector of the equipment under test. The signal level is the available average power into 50 Ω measured over the useful part of a burst through the appropriate filter, refer to clause B.1.2.2.

7.2.2 Nominal error rates

7.2.2.1 Definition

The nominal error rate is a measure of the receiver performance under nominal channel conditions. Nominal channel conditions are defined as a received signal level \geq -85 dBm with no interference under both static and fading conditions.

7.2.2.2 Limit values for phase modulation

The nominal bit error rate shall be measured. The cases to be tested and the corresponding limit values are given in the tables of clause A.2.

These requirements shall be measured under normal test conditions.

7.2.2.3 Limit values for QAM

The nominal bit error rate shall be measured. The cases to be tested and the corresponding limit values are given in the tables of clause A.2.

These requirements shall be measured under normal test conditions.

7.2.3 Reference sensitivity performance

7.2.3.1 Definition

The minimum required reference sensitivity performance is specified for V+D equipment according to test condition, logical channel, propagation condition, BS transmission mode, the receiver class, modulation type and channel bandwidth.

7.2.3.2 Limit values for phase modulation

The maximum dynamic and static reference sensitivity levels for a BS receiver under normal and extreme test conditions shall not exceed the signal levels shown in tables 7.14 and 7.15.

Table 7.14: BS receiver minimum reference sensitivity for $\pi/4$ -DQPSK

Test condition	Dynamic reference sensitivity	Static reference sensitivity
Normal	-106 dBm	-115 dBm
Extreme	-100 dBm	-109 dBm

Table 7.15: BS receiver minimum reference sensitivity for $\pi/8$ -D8PSK

Test condition	Dynamic ref. Sensitivity	Static reference sensitivity
Normal	-100 dBm	-110 dBm
Extreme	-94 dBm	-104 dBm

The maximum dynamic and static reference sensitivity levels for a MS receiver under normal and extreme test conditions shall not exceed the signal levels shown in tables 7.16 and 7.17.

Table 7.16: MS receiver minimum reference sensitivity for $\pi/4$ -DQPSK

Test condition	Dynamic reference sensitivity	Static reference sensitivity
Normal	-103 dBm	-112 dBm
Extreme	-97 dBm	-106 dBm

Table 7.17: MS receiver minimum reference sensitivity $\pi/8$ -D8PSK

Test condition	Dynamic ref. Sensitivity	Static reference sensitivity
Normal	-97 dBm	-107 dBm
Extreme	-91 dBm	-101 dBm

The cases to be tested and the corresponding limit values for BER or MER are given in the tables of clause A.2. Reference sensitivity requirements shall be tested under both normal and in certain cases extreme test conditions

Only in the case where an MS or BS supports protected circuit mode data, shall the TCH/2,4 receiver sensitivity measurement be conducted.

For BSCH, SCH/HD, SCH/HU, SCH/F and BNCH, a PUEM < 0,001 % shall be achieved at the $\pi/4$ -DQPSK dynamic reference sensitivity level. For AACH, a PUEM < 0,01 % shall be achieved at the $\pi/4$ -DQPSK dynamic reference sensitivity level.

For SCH-P8/HD, SCH-P8/HU and SCH-P8/F, a PUEM < 0,001 % shall be achieved at the $\pi/8$ -D8PSK dynamic reference sensitivity level.

The cases to be tested, the number of required samples and the test limit values for PUEM are given in clause A.2. The PUEM tests shall be conducted under normal test conditions only.

7.2.3.3 Limit values for QAM

Tables 7.18 to 7.20 specify dynamic reference sensitivity for 800 MHz frequency band 4-QAM, 16-QAM and 64-QAM respectively for normal test conditions. Add 6 dB for extreme test conditions.

Table 7.18: 800 MHz BS and MS dynamic reference sensitivity for 4-QAM

Channel BW	BS, $r = 1/2$	MS, $r = 1/2$
25 kHz	-111 dBm	-108 dBm
50 kHz	-108 dBm	-105 dBm
100 kHz	-105 dBm	-102 dBm
150 kHz	-104 dBm	-101 dBm

Table 7.19: 800 MHz BS and MS dynamic reference sensitivity for 16-QAM

Channel BW	BS, $r = 1/2$	MS, $r = 1/2$
25 kHz	-107 dBm	-103 dBm
50 kHz	-103 dBm	-100 dBm
100 kHz	-100 dBm	-97 dBm
150 kHz	-99 dBm	-96 dBm

Table 7.20: 800 MHz BS and MS dynamic reference sensitivity for 64-QAM

Channel BW	BS, $r = 1/2$	BS, $r = 2/3$	MS, $r = 1/2$	MS, $r = 2/3$
25 kHz	-102 dBm	-98 dBm	-99 dBm	-95 dBm
50 kHz	-98 dBm	-94 dBm	-95 dBm	-91 dBm
100 kHz	-96 dBm	-92 dBm	-93 dBm	-89 dBm
150 kHz	-94 dBm	-90 dBm	-92 dBm	-88 dBm

Tables 7.21 to 7.23 specify dynamic reference sensitivity for 400 MHz frequency band 4-QAM, 16-QAM and 64-QAM respectively for normal test conditions. Add 6 dB for extreme test conditions.

Table 7.21: 400 MHz BS and MS dynamic reference sensitivity for 4-QAM

Channel BW	BS, $r = 1/2$	MS, $r = 1/2$
25 kHz	-111 dBm	-108 dBm
50 kHz	-108 dBm	-105 dBm
100 kHz	-105 dBm	-102 dBm
150 kHz	-104 dBm	-101 dBm

Table 7.22: 400 MHz BS and MS dynamic reference sensitivity for 16-QAM

Channel BW	BS, $r = 1/2$	MS, $r = 1/2$
25 kHz	-106 dBm	-103 dBm
50 kHz	-102 dBm	-100 dBm
100 kHz	-100 dBm	-97 dBm
150 kHz	-99 dBm	-96 dBm

Table 7.23: 400 MHz BS and MS dynamic reference sensitivity for 64-QAM

Channel BW	BS, $r = 1/2$	BS, $r = 2/3$	MS, $r = 1/2$	MS, $r = 2/3$
25 kHz	-101 dBm	-98 dBm	-98 dBm	-95 dBm
50 kHz	-98 dBm	-94 dBm	-95 dBm	-91 dBm
100 kHz	-95 dBm	-92 dBm	-92 dBm	-88 dBm
150 kHz	-94 dBm	-91 dBm	-91 dBm	-87 dBm

The minimum required static reference sensitivity performance for MS is specified in tables 7.24 and 7.25.

Table 7.24: QAM sensitivity levels for MS

Channel BW	4-QAM 3 % BER Sensitivity	16-QAM 3 % BER Sensitivity	64-QAM 3 % BER Sensitivity
25 kHz	-113 dBm	-106 dBm	-101 dBm
50 kHz	-110 dBm	-103 dBm	-97 dBm
100 kHz	-107 dBm	-100 dBm	-95 dBm
150 kHz	-105 dBm	-99 dBm	-93 dBm

The minimum required static reference sensitivity performance for BS is specified in table 7.25.

Table 7.25: QAM sensitivity levels for BS

Channel BW	4-QAM 3 % BER Sensitivity	16-QAM 3 % BER Sensitivity	64-QAM 3 % BER Sensitivity
25 kHz	-116 dBm	-109 dBm	-104 dBm
50 kHz	-113 dBm	-106 dBm	-100 dBm
100 kHz	-110 dBm	-103 dBm	-98 dBm
150 kHz	-108 dBm	-102 dBm	-96 dBm

The cases to be tested and the corresponding limit values for BER or FER are given in the tables of clause A.2. Reference sensitivity requirements shall be tested under both normal and in certain cases extreme test conditions.

7.2.4 Reference interference performance

7.2.4.1 Definition

The minimum required reference interference performance (for co-channel C/I_c or adjacent channel C/I_a) is specified for V+D equipment with phase modulation according to test condition, channel type, propagation condition and the receiver class of the equipment.

The minimum required reference **adjacent channel** interference performance is specified for V+D equipment with QAM according to the wanted signal number of sub-carriers.

The minimum required reference **co-channel** interference performance is specified for V+D equipment with QAM according to channel bandwidth, modulation, coding rate and propagation conditions.

7.2.4.2 Limit values for phase modulation

The minimum required reference interference performance (for co-channel, C/I_c , or adjacent channel, C/I_a) is specified according to the logical channel, the propagation condition and the receiver class at the reference interference ratio. The reference interference ratio shall be, for BS and all types of MS for $\pi/4$ -DQPSK modulation:

- for co-channel interference $C/I_c = 19$ dB for MS and BS;
- for adjacent channel interference below 700 MHz $C/I_a = -40$ dB for MS; and
 $C/I_a = -45$ dB for BS;
- for adjacent channel interference above 700 MHz $C/I_a = -40$ dB for MS and BS.

The reference interference ratio shall be, for BS and all types of MS for $\pi/8$ -D8PSK modulation:

- for co-channel interference $C/I_c = 25$ dB for MS and BS;
- for adjacent channel interference below 700 MHz $C/I_a = -34$ dB for MS; and
 $C/I_a = 39$ dB for BS;
- for adjacent channel interference above 700 MHz $C/I_a = 34$ dB for MS and BS.

In the case of co-channel interference these specifications apply for a wanted input signal level of -85 dBm, and in the case of adjacent channel interference, for a wanted input signal 3 dB above the dynamic reference sensitivity level under appropriate test conditions. In the case of co-channel interference the interference is a continuous TETRA random modulated signal (test signal T2) subjected to an independent realization of the same propagation condition as the wanted signal. In the case of adjacent channel interference the interference is a continuous TETRA random modulated signal (test signal T2) subjected to static propagation conditions.

The cases to be tested and the corresponding limit values for BER or MER are given in the tables of clause A.2.

These requirements shall be measured under normal and in the case of adjacent channel interference, extreme test conditions.

7.2.4.3 Limit values for QAM

7.2.4.3.1 Adjacent channel interference

The minimum required reference adjacent channel interference performance is specified in table 7.26 according to the wanted signal channel bandwidth.

Table 7.26: Adjacent channel interferer frequency offsets and mean power levels for QAM

QAM Channel bandwidth	TETRA $\pi/4$ -DQPSK Interferer offset from f_0	TETRA $\pi/4$ -DQPSK Interferer level for MS	TETRA $\pi/4$ -DQPSK Interferer level for BS
25 kHz	25 kHz	-63 dBm	-62 dBm
50 kHz	37,5 kHz	-65 dBm	-65 dBm
100 kHz	62,5 kHz	-65 dBm	-65 dBm
150 kHz	87,5 kHz	-65 dBm	-65 dBm

The static reference sensitivity performance shall be met when the following signals are simultaneously input to the receiver:

- a wanted signal at the nominal receive frequency f_0 , 3 dB above the static reference sensitivity level; and
- a TETRA $\pi/4$ -DQPSK random modulated continuous signal at a frequency offset from f_0 and level as defined in table 7.26.

The cases to be tested and the corresponding limit values for BER or FER are given in the tables of clause A.2.

These requirements shall be measured under normal and extreme test conditions.

7.2.4.3.2 Co-channel interference

The minimum required reference co-channel interference performance is specified according to channel bandwidth, modulation, coding rate and propagation conditions. For BS co-channel interference ratio is defined for SCH-Q/U logical channel. For MS co-channel interference ratio is defined for SCH-Q/D logical channel. Co-channel interference specifications apply for a wanted input signal level of 25 dB above dynamic reference sensitivity (as specified in tables 7.18 to 7.23).

Table 7.27 defines co-channel interference ratios C/I_c , for frequencies below 700 MHz. Table 7.28 defines co-channel interference ratios C/I_c , for frequencies above 700 MHz. The maximum permissible FER for reference co-channel interference ratios is 10 %.

Table 7.27: BS and MS minimum dynamic reference interference ratio (C/I_c for 10 % FER) for frequencies below 700 MHz

Modulation	$r = 1/2$ TU50	$r = 1/2$ HT200	$r = 2/3$ TU50	$r = 2/3$ HT200
4-QAM	14 dB	12 dB	-	-
16-QAM	19 dB	17 dB	-	-
64-QAM	23 dB	22 dB	27 dB	26 dB

Table 7.28: BS and MS minimum dynamic reference interference ratio (C/I_c for 10 % FER) for frequencies above 700 MHz

Modulation	$r = 1/2$ TU50	$r = 1/2$ HT200	$r = 2/3$ TU50	$r = 2/3$ HT200
4-QAM	14 dB	12 dB	-	-
16-QAM	19 dB	17 dB	-	-
64-QAM	24 dB	23 dB	27 dB	29 dB

The cases to be tested and the corresponding limit values for BER or FER are given in the tables of clause A.2.

These requirements shall be measured under normal test conditions.

7.2.5 Blocking characteristics

7.2.5.1 Definition

Blocking is a measure of the capability of the receiver to receive a modulated wanted input signal in the presence of an unwanted unmodulated input signal on frequencies other than those of the spurious responses or the adjacent channels, without this unwanted input signal causing a degradation of the performance of the receiver beyond a specified limit. The blocking performance specification shall apply at all frequencies within the relevant receive band of the equipment, except those at which spurious responses occur (see clause 7.2.6).

7.2.5.2 Limit values for phase modulation

The reference sensitivity performance for the TCH/7,2 for V+D equipment, as specified in clause A.2 under static conditions, shall be met when the following signals are simultaneously input to the receiver:

- a wanted signal at nominal receive frequency f_0 , 3 dB above the static reference sensitivity level as specified in clause 7.2.3.2;
- a continuous sine wave signal (test signal T3) at frequency offsets of ± 1 MHz, ± 2 MHz, ± 5 MHz and ± 10 MHz from the nominal receive frequency f_0 and at a minimum level of -25 dBm.

This requirement shall be measured under normal test conditions.

7.2.5.3 Limit values for QAM

The reference sensitivity performance for the SCH-Q/D for V+D equipment, as specified in clause A.2 under static conditions, shall be met when the following signals are simultaneously input to the receiver:

- a wanted signal at the nominal receive frequency f_0 , 3 dB above the static reference sensitivity;
- a continuous sine wave signal at a frequency offset from f_0 and level as defined in tables 7.29, 7.30, 7.31 and 7.32.

This requirement shall be measured under normal test conditions.

Table 7.29: Blocking levels of the 25 kHz (8 subchannels) QAM receiver

Offset from nominal Rx freq.	Level of interfering signal
±75 kHz	-40 dBm
±150 kHz	-35 dBm
±350 kHz	-30 dBm
±1 MHz	-25 dBm
±2 MHz	
±5 MHz	
±10 MHz	

Table 7.30: Blocking levels of the 50 kHz (16 subchannels) QAM receiver

Offset from nominal Rx freq.	Level of interfering signal
±150 kHz	-40 dBm
±350 kHz	-35 dBm
±700 kHz	-30 dBm
±2 MHz	-25 dBm
±5 MHz	
±10 MHz	

Table 7.31: Blocking levels of the 100 kHz (32 subchannels) QAM receiver

Offset from nominal Rx freq.	Level of interfering signal
±250 kHz	-40 dBm
±500 kHz	-35 dBm
±700 kHz	-30 dBm
±2 MHz	-25 dBm
±5 MHz	
±10 MHz	

Table 7.32: Blocking levels of the 150 kHz (48 subchannels) QAM receiver

Offset from nominal Rx freq.	Level of interfering signal
±400 kHz	-40 dBm
±650 kHz	-35 dBm
±900 kHz	-30 dBm
±2 MHz	-25 dBm
±5 MHz	
±10 MHz	

7.2.6 Spurious response rejection

7.2.6.1 Definition

Spurious response rejection is a measure of the capability of a receiver to receive a wanted modulated signal without exceeding a given degradation due to the presence of an unwanted unmodulated signal at any other frequency at which a response is obtained, i.e. for which the blocking limit is not met.

7.2.6.2 Limit values for phase modulation

- a) The reference sensitivity performance for the TCH/7,2 for V+D equipment, as specified in clause A.2 under static conditions, shall be met when the following signals are simultaneously applied to the receiver:
- a wanted signal at nominal receive frequency f_0 , 3 dB above the static reference sensitivity level as specified in clause 7.2.3.2;
 - a continuous sine wave signal (test signal T3) at frequency f as defined in clause A.1 at a level of -45 dBm.
- b) The number of spurious responses where the blocking requirements as defined in a) are not met shall not exceed $0,05 \times$ (number of frequency channels in the limited frequency range, as defined in clause A.1).

This requirement shall be measured under normal test conditions.

7.2.6.3 Limit values for QAM

- a) The static reference sensitivity performance as specified in clause 7.2.3 shall be met when the following signals are simultaneously applied to the receiver:
- a wanted signal at nominal receive frequency f_0 , 3 dB above the static reference sensitivity;
 - a continuous sine wave signal (test signal T3) with any offset from nominal Rx frequency $\geq f_{spur}$ at a level of -45 dBm. The value f_{spur} is defined in table 7.33.

Table 7.33: Continuous sine wave offset frequency f_{spur}

QAM Channel bandwidth	Offset from nominal Rx freq.
25 kHz	50 kHz
50 kHz	100 kHz
100 kHz	200 kHz
150 kHz	300 kHz

- b) The number of spurious responses where the blocking requirements as defined in a) are not met shall not exceed $0,05 \times$ (number of frequency channels in the limited frequency range, as defined in clause A.1).

This requirement shall be measured under normal test conditions.

7.2.7 Intermodulation response rejection

7.2.7.1 Definition

Intermodulation response rejection is a measure of the capability of the receiver to receive a wanted modulated signal without exceeding a given degradation due to the presence of two or more unwanted signals with a specific frequency relationship to the wanted signal frequency.

7.2.7.2 Limit values

The reference sensitivity performance for TCH/7,2, SCH-P8/HD, SCH-P8/F and TCH-P8/10,8 for phase modulation and SCH-Q/D for QAM, for V+D equipment, as specified in clause A.2 under static conditions, shall be met when the following signals are simultaneously input to the receiver:

- a wanted signal at nominal receive frequency f_0 , 3 dB above the static reference sensitivity level as specified in clause 7.2.3.2 for phase modulation and clause 7.2.3.3 for QAM;
- a continuous sine wave signal (test signal T3) at frequency f_1 with level -47 dBm;
- a $\pi/4$ -DQPSK modulated (phase modulated test signal T2) continuous radio signal at frequency f_2 , with level -47 dBm, such that $f_0 = 2f_1 - f_2$ and $|f_2 - f_1| = f_x$. Where $f_x = 200$ kHz for phase modulated wanted signal or where f_x is defined in table 7.34 for QAM wanted signal.

Therefore for any given frequency f_0 .

If $f_2 - f_1 = f_x$

Then $f_1 = f_0 + f_x$ and $f_2 = f_0 + 2f_x$

Else if $f_1 - f_2 = f_x$

Then $f_1 = f_0 - f_x$ and $f_2 = f_0 - 2f_x$.

Table 7.34: f_x definition

QAM Channel bandwidth	Offset from nominal Rx freq.
25 kHz	200 kHz
50 kHz	400 kHz
100 kHz	800 kHz
150 kHz	1 200 kHz

This requirement shall be measured under normal test conditions.

7.2.8 Unwanted conducted emissions

7.2.8.1 Definition

Unwanted emissions from a MS or BS when in reception (non-transmit state) are signals at any frequency emitted by the MS or BS.

7.2.8.2 Limit values

The unwanted conducted emissions shall be less than -57 dBm measured in the frequency range from 9 kHz to 1 GHz as measured in a 100 kHz bandwidth. For equipment only capable of operating at frequencies below 470 MHz, the unwanted conducted emissions shall be less than -47 dBm measured in the frequency range from 1 GHz to 4 GHz, as measured in a bandwidth of 1 MHz. For equipment capable of operating at frequencies above 470 MHz, the unwanted conducted emissions shall be less than -47 dBm from 1 GHz to 12,75 GHz, as measured in a bandwidth of 1 MHz.

These requirements shall be measured under normal test conditions.

7.2.9 Unwanted radiated emissions

7.2.9.1 Definition

Unwanted radiated emissions are emissions (whether modulated or unmodulated) radiated by the cabinet and structure of the equipment (MS or BS), when the equipment is in the non-transmit state.

7.2.9.2 Limit values

The limits given in clause 7.2.8.2 shall apply for frequencies between 30 MHz and 4 GHz only.

7.3 Transmitter/receiver parameter definitions and limits

7.3.1 Modulation accuracy

7.3.1.1 Definition

Modulation accuracy is defined according to ETSI EN 300 392-2 [1], clause 6 as a difference between the actual transmitted signal waveform and the ideal signal waveform. The difference is specified in terms of vector error magnitudes at a symbol time. The parameters to be measured for phase modulation are RMS vector error, peak vector error and the residual carrier magnitude of the transmitter. The only parameter to be measured for QAM is RMS vector error.

7.3.1.2 Limit values for phase modulation

RMS vector error: less than 0,1 in any burst.

Peak vector error: less than 0,3 for any symbol.

Residual carrier magnitude shall be less than 5 % in any burst.

These requirements shall be measured under normal test conditions.

7.3.1.3 Limit values for QAM

The RMS vector error in any burst shall be less than 0,1.

This requirement shall be measured under normal test conditions.

7.3.2 Carrier frequency accuracy

7.3.2.1 Definition

Carrier frequency accuracy (error) is defined as a difference between the actual transmitted carrier frequency and its nominal value.

7.3.2.2 Limit values

The BS carrier frequency error in any burst shall be within $\pm 0,2$ ppm for frequencies up to 520 MHz. At carrier frequencies above 520 MHz the BS frequency error in any burst shall be within $\pm 0,1$ ppm. This requirement shall be measured under normal test conditions.

NOTE: The BS frequency accuracy is specified in ppm due to the requirement for timebase accuracy defined in ETSI EN 300 392-2 [1], clause 7.7.

The MS carrier frequency error in any burst shall be within ± 100 Hz measured under normal test conditions.

7.3.3 MS receiver performance for synchronization burst acquisition

7.3.3.1 Definition for phase modulation

This clause specifies reference sensitivity performance of a MS receiver for the acquisition of the Synchronization (sub) Burst (SB) in V+D standard. The performance is defined in terms of the probability PACQ of detecting a single transmitted SB and correctly decoding its BSCH information for the condition where the MS is listening on the frequency while the SB is transmitted, and where the MS is already frequency synchronized but not synchronized in terms of time slots.

7.3.3.2 Limit values for phase modulation

The MS receiver PACQ performance specified in table 7.35 shall be met with a wanted signal level at the dynamic reference sensitivity level.

Table 7.35: MS receiver PACQ

Receiver Class	Propagation Condition	PACQ
A, E	HT200	0,8
B	TU50	0,8

The propagation models specified (TU50, HT200) are defined in ETSI EN 300 392-2 [1], clause 6.8.3.

For test purposes, with a limited number of samples (20 synchronization bursts) a test limit of 0,55 instead of 0,8 shall apply for both propagation conditions. This corresponds to 11 successful acquisitions. The present document applies to continuous or discontinuous downlink mode.

This requirement shall be measured under normal test conditions.

7.3.3.3 Definition for QAM modulation

This clause specifies reference sensitivity performance of a MS receiver for the acquisition of the Frequency Correction Burst (FCB) in V+D standard. The performance is defined in terms of the probability PACQ of detecting a single transmitted FCB and correctly decoding its BSCH-Q information for the condition where the MS is listening on the frequency while the FCB is transmitted, and where the MS is already frequency synchronized but not synchronized in terms of time slots.

7.3.3.4 Limit values for QAM modulation

The MS receiver PACQ performance specified in table 7.36 shall be met with a wanted signal level at the dynamic reference sensitivity level as defined in ETSI EN 300 392-2 [1], clause 6.7.2.2.

Table 7.36: MS receiver PACQ for QAM Modulation

Propagation Condition	PACQ
HT200	0,8
TU50	0,8

The propagation models specified (TU50, HT200) are defined in ETSI EN 300 392-2 [1], clause 6.8.3.

For test purposes, with a limited number of samples (20 frequency correction bursts) a test limit of 0,55 instead of 0,8 shall apply for both propagation conditions. This corresponds to 11 successful acquisitions.

This requirement shall be measured under normal test conditions.

7.3.4 MS Frame alignment performance

7.3.4.1 Definition

Frame alignment performance is defined as the capability of the MS to adjust its burst transmission time with reference to the signals received from the serving BS, when the MS to BS distance is varying with time.

7.3.4.2 Limit values

The timing of each burst sent by the MS shall not differ by more than $\pm 125/9 \mu\text{s}$ (ETSI EN 300 392-2 [1], clause 7) from the timing reference received from the BS.

This requirement shall be measured under normal test conditions.

7.3.5 MS link control

7.3.5.1 Definition

The MS shall be capable of setting its initial transmit output power based upon the received signal strength measured and the power control parameters broadcast by the serving BS on the BNCH.

7.3.5.2 Limit values

The MS shall use its nominal power control level that is closest to P_{MS} , where P_{MS} is defined by ETSI EN 300 392-2 [1], clause 23:

- $P_{\text{MS}} = \text{MIN}(\text{MS_TXPWR_MAX_CELL}, \text{ACCESS_PARAMETER} - \text{RSSI})$;

where:

- MS_TXPWR_MAX_CELL = maximum MS transmit power allowed in the cell;
- ACCESS_PARAMETER = parameter for access power calculation;
- RSSI = averaged signal level received by the MS or an equivalent signal quality measurement.

All values are expressed in dBm. The nominal MS power control level shall not exceed the maximum MS transmit power indicated in the MS_TXPWR_MAX_CELL parameter for that channel.

NOTE: ACCESS_PARAMETER is based on the BS power and configuration and on the required mean receive power level at the BS. On a QAM channel, it is expected that the BS will set the ACCESS_PARAMETER so that the MS power is not reduced until the MS could use the highest permitted uplink bit rate (with the possible exception of coding rate $r = 1$) for some data categories.

The measured MS transmit power shall be within ± 9 dB of the value P_{MS} defined above, when P_{MS} is within the MS power control range. The tolerances specified above include the contribution of the following sources of error:

- acceptable signal strength measurement uncertainty in the MS (ETSI EN 300 392-2 [1], clause 23): ± 4 dB;
- nominal steps of 5 dB between adjacent MS power control levels: $\pm 2,5$ dB;
- acceptable uncertainty in setting the MS transmit power: $\pm 2,5$ dB.

In any case, when P_{MS} is outside the MS power control range by more than 3,5 dB the highest or lowest power control level supported by the MS shall be used accordingly. In that case the power tolerances specified in clause 7.1.1 shall apply.

In order to reduce the uncertainties contributing to the tolerance specified above, the link control test shall be performed using the test cases shown in table 10.1. For each test case, the measured MS transmit power shall not exceed the maximum power shown in table 10.1.

These requirements shall be measured under normal test conditions.

8 Methods of measurement for transmitter parameters

8.1 Transmitter output power

8.1.0 Test conditions

The test shall be carried out under normal and extreme (LTLV, HTHV) test conditions specified in clause 6. A test configuration as presented in clause 5.1 should be applied. The sampling system described in clause B.1.2 shall be employed.

8.1.1 Transmitter output power for phase modulation

8.1.1.1 MS transmitter output power for phase modulation

- a) The MS shall be connected to the test system. The test system shall transmit test signal T1 as indicated in clause 5.2.2.1. Test signal T1 level and BNCH/T parameters shall be initially set as detailed in table 8.1 and transmitted on the desired downlink frequency.

Table 8.1: T1 initial setup

T1 Signal	Setting
T1 level (dBm)	-100
ACCESS_PARAMETER (dBm)	-23
MS_TXPWR_MAX_CELL	45
T1_T4_burst_type	Type 1
Loopback	Off
Tx_on	Reception on
Tx_burst_type	Normal

- The T1 signal level is referenced to the antenna connector of the equipment under test. The signal level is the available average power into 50 Ω measured over the useful part of a burst through the TETRA filter, refer to clause B.1.2.2.
 - The MS shall be set to test receive mode as indicated in clause 5.2.1.1 for a period of at least 5 s in which it will decode BSCH and BNCH/T information and measure T1 signal strength. The MS shall then be set to test transmit mode as indicated in clause 5.2.2.1. The MS shall use the T1 level, ACCESS_PARAMETER and MS_TXPWR_MAX_CELL parameters to set its transmitter output power to the nominal MS power control levels for the test cases shown in table 8.2, as required by each transmitter test.
- b) The sampling system shall capture a representation of the MS transmit burst's (excluding any CLCH transmissions) amplitude and timing. The procedure shall be repeated for 200 bursts and the test system shall calculate the following two parameters:
- b1) the average power versus time profile during time periods t_1 and t_3 (figure 6.3 in ETSI EN 300 392-2 [1], and in ETSI EN 300 392-2 [1], annex O, figure O.4 and table O.2 for the air to ground service), extended at least 5 symbol periods before the start of t_1 and at least 5 symbol periods after the end of t_3 , sampled at a rate equal to or greater than the symbol rate, where each point represents the average power per sample, as estimated from the 200 arrays;
 - b2) the average power over the useful part of a burst as defined in ETSI EN 300 392-2 [1], sampled at symbol rate at symbol time, further averaged over the 200 burst measurements. This single power value shall be used as the 0 dB reference for the power versus time profile determined in step b1) above.

- c) The steps a) and b) shall be repeated for the MS_TXPWR_MAX_CELL parameters detailed in test cases 2 to 7 of table 8.2 and shall be performed on the lowest, highest and middle radio frequency channel in the MS transmit band.

Table 8.2: Test cases to set nominal MS power control levels

test case	MS_TXPWR_MAX_CELL (dBm)	Nominal MS power control level (note)
1	45	PL1
2	40	PL2
3	35	PL3
4	30	PL4
5	25	PL5
6	20	PL6
7	15	PL7
NOTE: Or MS Power Class if lower.		

- d) The test procedure above shall be repeated with the T1_T4_burst_type information element of the BNCH/T set to type 21 (where supported). The MS under test shall transmit TCH-P8/10,8 signal type ($\pi/8$ -D8PSK modulation).

8.1.1.2 BS transmitter output power for phase modulation

- a) The BS shall be connected to the test system and shall be set to test transmit mode using a $\pi/4$ -DQPSK modulation burst type. The BS shall operate in its normal mode i.e. continuous or discontinuous transmission and transmit at the BS maximum nominal output power level.
- b) The sampling system shall capture a representation of the BS transmit burst's amplitude and timing (excluding any BLCH transmissions by only capturing Normal Downlink Bursts with Normal Training Sequence 1, defined in ETSI EN 300 392-2 [1], clause 9). The procedure shall be repeated for 200 bursts and the test system shall calculate the following parameters:
- b1) in the case of a discontinuous BS the average power versus time profile during time periods t_1 and t_3 (figure 6.3 in ETSI EN 300 392-2 [1]), extended at least 5 symbol periods before the start of t_1 and at least 5 symbol periods after the end of t_3 , sampled at a rate equal to or greater than the symbol rate, where each point represents the average power per sample, as estimated from the 200 arrays;
- b2) the average power over the useful part of a burst as defined in ETSI EN 300 392-2 [1], sampled at symbol rate at symbol time, further averaged over the 200 burst measurements. This single power value shall be used as the 0 dB reference for the power versus time profile determined in step b1) above.
- c) If applicable steps a) and b) shall be repeated at the BS minimum nominal power level.
- d) The tests shall be performed on the lowest, highest and middle radio frequency channel in the BS transmit band.
- e) The tests shall be repeated with $\pi/8$ -D8PSK modulation (where supported).

8.1.2 Transmitter output power for QAM

8.1.2.1 MS transmitter output power for QAM

- a) The MS shall be connected to the test system. The test system shall transmit the QAM test signal T4 as indicated in clause 5.2.2.2 continuously with channel type 27. The test signal level and BNCH/T parameters shall be initially set as detailed in table 8.3 and transmitted on the desired downlink frequency.

Table 8.3: T4 initial setup

T4 Signal	Setting
T4 level (dBm)	-100
ACCESS_PARAMETER (dBm)	-23
MS_TXPWR_MAX_CELL	45
burst_type	Type 27
Loopback	Off
Tx_on	Reception on
Tx_burst_type	Normal
Error correction	0
Bandwidth of QAM channel	25

- The T4 signal level is referenced to the antenna connector of the equipment under test. The signal level is the available average power into 50 Ω measured over the useful part of a burst.
 - The MS shall be set to test receive mode as indicated in clause 5.2.1.3 for a period of at least 5 s in which it will decode BSCH and BNCH/T information and measure T4 signal strength. The MS shall then be set to test transmit mode as indicated in clause 5.2.2.2. The MS shall use the T4 level, ACCESS_PARAMETER and MS_TXPWR_MAX_CELL parameters to set its transmitter output power to the nominal MS power control levels for the test cases shown in table 8.2, as required by each transmitter test.
- b) The sampling system shall capture a representation of the MS transmit burst's (excluding any CLCH transmissions) amplitude and timing. The procedure shall be repeated for 200 bursts and the test system shall calculate the following parameters:
- b1) the average power versus time profile during time periods t_1 and t_3 (figure 6.4 in ETSI EN 300 392-2 [1]), extended at least 2 symbol periods before the start of t_1 and at least 2 symbol periods after the end of t_3 , sampled at a rate equal to or greater than the symbol rate, where each point represents the average power per sample, as estimated from the 200 arrays;
 - b2) the average power over the useful part of a burst as defined in ETSI EN 300 392-2 [1]. This is the sum of the powers of each of the sub-carriers within the RF channel bandwidth. For each sub-carrier, reference power is the average power, measured at symbol time through the square root raised cosine filter defined in ETSI EN 300 392-2 [1], clause 5.16, over the pilot and sync symbols within the QAM burst, further averaged over the 200 burst measurements. The average power value shall be used as the 0 dB reference for the power versus time profile determined in step b1) above;
 - b3) each individual pilot sub-carrier symbol power. This shall be measured to compare with the reference power from that sub-carrier.
- c) The steps a) and b) shall be repeated for the MS_TXPWR_MAX_CELL parameters detailed in test cases 1 to 7 of table 8.2 and shall be performed on the lowest, highest and middle radio frequency channel in the MS transmit band.
- d) This test shall be performed (where supported) using 4-QAM, 16-QAM, and 64-QAM modulation and at 25 kHz, 50 kHz, 100 kHz, and 150 kHz channel bandwidths.

8.1.2.2 BS transmitter output power for QAM

- a) The BS shall be connected to the test system and shall be set to test transmit mode using a QAM normal downlink burst type. The BS shall transmit at the BS maximum nominal output power level.

- b) The sampling system shall capture a representation of the BS transmit burst's amplitude and timing (excluding any linearization down-link burst transmissions by only capturing Normal Downlink Bursts, defined in ETSI EN 300 392-2 [1], clause 9). The procedure shall be repeated for 200 bursts and the test system shall calculate the following parameters:
 - b1) the average power over the useful part of a burst as defined in ETSI EN 300 392-2 [1]. This shall be defined as the sum of the powers of each of the sub-carriers within the RF channel bandwidth. For each sub-carrier, reference power is defined as the average power, measured at symbol time through the square root raised cosine filter, over the pilot and sync symbols within the QAM, further averaged over the 200 burst measurements;
 - b2) each individual pilot sub-carrier symbol power. This shall be measured to compare with the reference power from that sub-carrier.
- c) If applicable steps a) and b) shall be repeated at the BS minimum nominal power level.
- d) This test shall be performed (where supported) using 4-QAM, 16-QAM, and 64-QAM modulation and at 25 kHz, 50 kHz, 100 kHz, and 150 kHz channel bandwidths.

8.2 Unwanted output power in non active transmit state

The test shall be carried out at maximum nominal power level only under the normal test conditions specified in clause 6.

The procedure detailed in clauses 8.1.1.1 a) and 8.1.2.1 a) for MS or clause 8.1.1.2 a) for discontinuous BS shall be used. The sampling system shall be used to measure the average unwanted transmitter output power during the non-active time slots occurring between the successive burst transmissions of the MS or BS operating in discontinuous mode. The equipment under test shall transmit a burst only in one timeslot per frame and, hence each transmitted burst is followed by three non-active time slots.

The test system shall calculate the average power over 200 non active time slots by applying the measurement procedure detailed in step b2) of clause 8.1.1.1 or clause 8.1.2.1 for MS and clause 8.1.1.2 for discontinuous BS to the active time slots, and by continuing to sample at a rate equal to or greater than the symbol rate during the whole non-active period of the non active time slots. The transmitter output power measured during active bursts shall be used as the 0 dB reference for the unwanted output power in non active transmit state measured here. The test shall be performed on the lowest, highest and middle radio frequency channels of the equipment's transmit band.

In the case of $\pi/8$ -D8PSK modulation (where supported), this test shall be repeated as indicated in clauses 8.1.1.1 d) and 8.1.1.2 e).

In the case of QAM modulation, this test shall be performed (where supported) using 4-QAM, 16-QAM, and 64-QAM modulation and at 25 kHz, 50 kHz, 100 kHz, and 150 kHz channel bandwidths.

8.3 Adjacent channel power due to modulation

The test shall be carried out at maximum and minimum nominal power levels only under normal and extreme (LTLV, HTHV) test conditions specified in clause 6.

The procedure detailed in clauses 8.1.1.1 a) and 8.1.2.1 a) for MS and in clauses 8.1.1.2 a) and 8.1.2.2 a) for BS shall be used. The sampling system shall be set to capture the transmit power (sampled at a rate equal to or greater than the symbol rate) appearing in the adjacent channels at the frequency offsets specified in clause 7.1.3 from the nominal centre frequency of the allocated channel. The power measurements described here shall be timed to occur only during the useful part of Normal Uplink Bursts transmitted by the MS, or Normal Downlink Bursts with Normal Training Sequence 1 (to exclude any BLCH transmissions) transmitted by the BS, defined in ETSI EN 300 392-2 [1], clause 9.

For each adjacent channel, the test system shall calculate the average power by measuring, through the TETRA filter, refer to clause B.1.2.2, the average power in the adjacent channel, sampled at a rate equal to or greater than the symbol rate, during the useful part of the burst in the allocated channel, further averaged over 200 burst measurements. The transmitter output power obtained by using the method described in clause 8.1 shall be used as the 0 dB reference for the adjacent channel power measured here. The test shall be conducted in the middle radio frequency channel of the equipment's transmit band and in the case of MS equipment repeated as per table 8.2 test case 7 (minimum power level) and if applicable at the BS minimum power level. In the case of $\pi/8$ -D8PSK modulation (where supported), this test shall be repeated as indicated in clauses 8.1.1.1 d) and 8.1.1.2 e).

In the case of QAM modulation, this test shall be performed (where supported) using 4-QAM, 16-QAM, and 64-QAM modulation and at 25 kHz, 50 kHz, 100 kHz, and 150 kHz channel bandwidths.

8.4 Adjacent channel power due to switching transients

The test shall be carried out under the normal test conditions specified in clause 6. The procedure detailed in clause 8.1.1.1 a) and in clause 8.1.2.1 a) for MS or in clause 8.1.1.2 a) for BS shall be used. The measurement shall be conducted only in the middle radio frequency channel of the MS or discontinuous mode BS transmit band. This test is carried out at maximum nominal power only.

The test procedure is similar to that described in clause 8.3, except that the measurements are performed only at the frequency offsets specified in clause 7.1.4. In this case, the sampling system shall capture a representation of the adjacent channel power (sampled with a rate of at least 4 times the symbol rate) during the ramp-up and ramp-down periods (t_1, t_3) of a burst transmitted by the equipment.

For each burst the test system shall record the peak power obtained. The procedure shall be repeated for 200 bursts and the results averaged. The transmitter output power obtained by using the method described in clause 8.1 shall be used as the 0 dB reference for the adjacent channel power measured here.

In the case of $\pi/8$ -D8PSK modulation (where supported), this test shall be repeated as indicated in clause 8.1.1.1 d) and in clause 8.1.1.2 e).

In the case of QAM modulation, this test shall be performed (where supported) using 4-QAM, 16-QAM, and 64-QAM modulation and at 25 kHz, 50 kHz, 100 kHz, and 150 kHz channel bandwidths.

8.5 Unwanted emissions far from the carrier

The tests shall be carried out under normal test conditions specified in clause 6. The procedure detailed in clauses 8.1.1.1 a) and 8.1.2.1 a) for MS or in clauses 8.1.1.2 a) and 8.1.2.2 a) for BS shall be used. The tests shall be performed at maximum nominal power level in the middle radio frequency channel only.

In the case of $\pi/8$ -D8PSK modulation (where supported), this test shall be repeated as indicated in clauses 8.1.1.1 d) and 8.1.1.2 e).

In the case of QAM modulation, this test shall be performed (where supported) using 4-QAM, 16-QAM, and 64-QAM modulation and at 25 kHz, 50 kHz, 100 kHz, and 150 kHz channel bandwidths.

Discrete spurious:

Discrete spurious emissions shall be measured as the average power over at least 200 bursts, timed to occur only during the useful part of the burst and covering at least 200 symbols in each phase modulated burst or 26 symbols in each QAM burst. The test system shall be connected to the antenna port of the equipment.

For frequency offsets greater than f_{rb} (where f_{rb} denotes the frequency offset corresponding to the near edge of the receive band or 5 MHz whichever is greater) a spectrum analyser with a resolution bandwidth according to table 8.4 shall be used.

Table 8.4: Measurement bandwidths

Measurement frequency	Resolution bandwidth	Video bandwidth (note 1)
9 kHz to 150 kHz	1 kHz	3 kHz
150 kHz to 30 MHz	10 kHz	30 kHz
30 MHz to 1 GHz (note 2)	100 kHz	300 kHz
1 GHz to 4 GHz	1 MHz	3 MHz
4 GHz to 12,75 GHz (note 3)	1 MHz	3 MHz
NOTE 1: When using a conventional swept frequency spectrum analyser.		
NOTE 2: Excluding frequencies within f_{rb} of the carrier.		
NOTE 3: Only for equipment capable of operating at frequencies greater than 470 MHz.		

For frequency offsets less than f_{rb} , the sampling system using a TETRA filter, refer to clause B.1.2.2, shall be used with a sample rate of at least 4 times the symbol rate. When a discrete spurious signal with a level greater than -36 dBm is detected, care shall be taken to subtract the maximum permitted level of wideband noise at that frequency (see tables 7.4 and 7.5) from the measured level before deciding whether it exceeds the specification.

A pre-scan may be performed to identify any potential discrete spurious emissions, using an appropriate technique.

Wideband noise:

Wideband noise level at selected frequency offsets from the on channel shall be measured through the TETRA filter, refer to clause B.1.2.2. In the case of phase modulated bursts, the selected frequency offsets shall cover at least 112,5 kHz, 262,5 kHz, 512,5 kHz and $f_{rb} + 12,5$ kHz where f_{rb} denotes the frequency offset corresponding to the near edge of the receive band or 5 MHz whichever is greater. For QAM modulated bursts, the selected frequency offsets shall cover at least the frequencies indicated in table 8.5. If a discrete spurious lies in one of these bands, then the closest discrete spurious free frequency which is higher shall be chosen. For each selected frequency offset the test system shall calculate the average power over at least 200 bursts, timed to occur only during the useful part of the burst and covering at least 200 symbols in each phase modulated burst or 26 symbols in each QAM burst. The Tx output power obtained by using the method described in clause 8.1 shall be used as the 0 dB reference for the unwanted emissions measured here.

Table 8.5: Selected frequency offsets for QAM Modulated bursts

QAM Bandwidth (kHz)	Frequency offset (kHz)
25	112,5
25	262,5
25	512,5
25	2 512,5
25	$f_{rb} + 12,5$
50	125
50	275
50	512,5
50	$f_{rb} + 12,5$
100	150
100	300
100	550
100	1 012,5
100	$f_{rb} + 12,5$
150	175
150	325
150	575
150	1 512,5
150	$f_{rb} + 12,5$

8.6 Unwanted radiated emissions

The test shall be carried out under normal test conditions specified in clause 6. The test shall be performed at maximum nominal power level in the middle radio frequency channel only.

Using the measurement arrangement shown in ETSI EN 300 113-1 [3], figure 9, on a test site fulfilling the requirements of ETSI EN 300 113-1 [3], clause A.2, the MS or BS under test shall be placed at the specified height on the support. For BS testing, the test shall be carried out using an artificial antenna which shall be a substantially non-reactive non-radiating load of $50\ \Omega$ connected to the antenna connector. For MS testing, the test may be carried out using an artificial antenna which shall be a substantially non-reactive non-radiating load of $50\ \Omega$ connected to the antenna connector, or the test may be carried out with a non-radiating cable connecting the MS antenna connector to the test system, located outside the test site, in order to provide the T1 signal to the MS.

The MS or BS shall be operated in test transmit mode at maximum nominal power; the procedure detailed in clauses 8.1.1.1 a) and 8.1.2.1 a) for MS or in clauses 8.1.1.2 a) and 8.1.2.2 a) for BS may be used. Emissions from the cabinet of the MS or BS under test shall be received by the test antenna connected to the test receiver.

The radiation of any discrete spurious emissions in the range 30 MHz to 4 GHz, occurring at offsets equal to or greater than 100 kHz from the carrier frequency, shall be measured over 200 bursts as the peak power level of any discrete signal delivered to the test receiver connected to the test antenna. The resolution bandwidth of the measuring instrument shall be the smallest bandwidth available which is greater than the spectral width of the spurious component being measured. This shall be considered to be achieved when the next highest bandwidth causes less than 1 dB increase in amplitude.

At each frequency at which a discrete spurious emission is detected, the MS or BS under test shall be rotated to obtain maximum response and the effective radiated power of that component determined by a substitution measurement, using the measurement arrangement of ETSI EN 300 113-1 [3], figure 10, where the substitution signal is T3.

The measurements shall be repeated with the test antenna in the orthogonal polarization plane.

A pre-scan may be performed to identify any potential discrete spurious emissions, using a suitable technique.

In the case of $\pi/8$ -D8PSK modulation (where supported), this test shall be repeated as indicated in clauses 8.1.1.1 d) and 8.1.1.2 e).

In the case of QAM modulation, this test shall be performed (where supported) using 4-QAM, 16-QAM, and 64-QAM modulation and at 25 kHz, 50 kHz, 100 kHz, and 150 kHz channel bandwidths.

8.7 Unwanted emissions during the BLCH/CLCH and BLCH-Q/CLCH-Q (linearization)

8.7.0 Test conditions

The test shall be carried out under normal test and extreme (LTLV, HTHV) conditions specified in clause 6. All normal transmissions from the equipment (excluding linearization bursts) shall meet the on-channel power requirements of clause 7.1.1.2 and the adjacent channel power requirements of clauses 7.1.3.2 and 7.1.4.2.

8.7.1 MS unwanted emissions during the CLCH (linearization)

The test shall be performed at maximum nominal power level in the middle radio frequency channel only, using the procedure detailed in clause 8.1.1.1 a).

Prior to any CLCH measurement the MS shall operate in the non-transmit (receive) state for a period of four minutes. Once the Tx_on parameter in the T1 BNCH/T information has been activated, only the transmitter emissions in the adjacent channel during the first CLCH period shall be measured.

For the CLCH measurement the sampling system shall be set to capture the transmit power appearing in either of the adjacent channels at the frequency offsets of ± 25 kHz from the nominal centre frequency of the allocated channel. The adjacent channel measurement shall be made using a TETRA filter, refer to clause B.1.2.2. Appropriate triggering shall be used to capture the adjacent channel transmissions during the first CLCH period. The measurement instrument shall capture a 7,5 ms time record in order to provide the peak adjacent channel power (dBm) vs. time domain response of the signal. It is recommended that a sampling rate of at least 4 samples per symbol duration is used.

The measurement instrument provides a peak adjacent channel power "dBm" reading for CLCH period measured. To obtain a "dBC" reading the measured "dBm" value is then subtracted from the normal average on-channel "dBm" power level, as measured at maximum nominal power level in clause 8.1 under the appropriate test conditions.

8.7.2 BS unwanted emissions during the BLCH (linearization)

The test shall be performed at maximum nominal power level in the middle radio frequency channel only, using the procedure detailed in clause 8.1.1.2 a).

Prior to any BLCH measurement, the BS shall be operating in BS test transmit mode as defined in clause 5.2.2.3.

For the BLCH measurement the sampling system shall be set to capture the transmit power appearing in either of the adjacent channels at the frequency offsets of ± 25 kHz from the nominal centre frequency of the allocated channel. The adjacent channel measurement shall be made using a TETRA filter, refer to clause B.1.2.2. The adjacent channel transmissions during a BLCH period shall be captured by timing the measurement to occur during block 2 of a Normal Downlink Burst with Normal Training Sequence 2, defined in ETSI EN 300 392-2 [1], clause 9. The measurement instrument shall capture a 6,0 ms time record in order to provide the peak adjacent channel power (dBm) vs. time domain response of the signal. It is recommended that a sampling rate of at least 4 samples per symbol duration is used.

The measurement instrument provides a peak adjacent channel power "dBm" reading for BLCH period measured. To obtain a "dBC" reading the measured "dBm" value is then subtracted from the normal average on-channel "dBm" power level, as measured at maximum nominal power level in clause 8.1 under the appropriate test conditions.

8.7.3 MS unwanted emissions during the CLCH-Q (linearization)

The test shall be performed at maximum nominal power level in the middle radio frequency channel only, using the procedure detailed in clause 8.1.2.1 a).

Prior to any CLCH-Q measurement the MS shall operate in the non-transmit (receive) state for a period of four minutes. Once the Tx_on parameter in the T1 BNCH/T information has been activated, only the transmitter emissions in the adjacent channel during the first CLCH-Q period shall be measured.

For the CLCH-Q measurement the sampling system shall be set to capture the transmit power appearing in either of the adjacent channels at the frequency offsets specified in clause 7.1.7.3 from the nominal centre frequency of the allocated channel. The adjacent channel measurement shall be made using a TETRA filter, refer to clause B.1.2.2. Appropriate triggering shall be used to capture the adjacent channel transmissions during the first CLCH period. The measurement instrument shall capture a 7,5 ms time record in order to provide the peak adjacent channel power (dBm) vs. time domain response of the signal. It is recommended that a sampling rate of at least 4 samples per symbol duration is used.

The measurement instrument provides a peak adjacent channel power "dBm" reading for CLCH-Q period measured. To obtain a "dBC" reading the measured "dBm" value is then subtracted from the normal average on-channel "dBm" power level, as measured at maximum nominal power level in clause 8.1 under the appropriate test conditions.

This test shall be performed (where supported) at 25 kHz, 50 kHz, 100 kHz, and 150 kHz channel bandwidths.

8.7.4 BS unwanted emissions during the BLCH-Q (linearization)

The test shall be performed at maximum nominal power level in the middle radio frequency channel only, using the procedure detailed in clause 8.1.2.2 a).

Prior to any BLCH-Q measurement, the BS shall be operating in BS test transmit mode as defined in clause 5.2.2.3.

For the BLCH-Q measurement the sampling system shall be set to capture the transmit power appearing in either of the adjacent channels at the frequency offsets specified in clause 7.1.7.3 from the nominal centre frequency of the allocated channel. The adjacent channel measurement shall be made using a TETRA filter, refer to clause B.1.2.2. The adjacent channel transmissions during a BLCH-Q period shall be captured by timing the measurement to occur during the linearization portion of the Linearization Downlink Burst (LDB), defined in ETSI EN 300 392-2 [1], clause 9. The measurement instrument shall capture the samples over the middle 20 symbols of linearization in order to provide the peak adjacent channel power (dBm) vs. time domain response of the signal. It is recommended that a sampling rate of at least 4 samples per symbol duration is used.

The measurement instrument provides a peak adjacent channel power "dBm" reading for BLCH-Q period measured. To obtain a "dBc" reading the measured "dBm" value is then subtracted from the normal average on-channel "dBm" power level, as measured at maximum nominal power level in clause 8.1 under the appropriate test conditions.

This test shall be performed (where supported) at 25 kHz, 50 kHz, 100 kHz, and 150 kHz channel bandwidths.

8.8 Transmitter intermodulation attenuation

8.8.0 Test procedure

The test shall be carried out under normal test conditions specified in clause 6. Referring to the test configuration presented in clause 5.1, the following equipment shall be employed:

- A spectrum analyser with 30 kHz measurement bandwidth as a power detecting device in frequency domain (clause B.1.3) and an unmodulated signal generator as an interfering signal source (test signal T3, clause 5.3.4). In addition, a directional coupler and RF attenuators shall be used to complete the measurement arrangement.
- Using the procedure detailed in clauses 8.1.1.1 a) and 8.1.2.1 a) for MS and in clauses 8.1.1.2 a) and 8.1.2.2 a) for BS, the equipment under test shall be set to test transmit mode and transmit at its maximum nominal power level on the middle radio frequency channel. The interfering (unmodulated) signal generator shall be set to deliver the desired output power level detailed below, at a frequency of 500 kHz above the transmitter under test frequency. The frequency of signal T3 shall if necessary be adjusted in steps of 25 kHz such that the intermodulation components to be measured do not coincide with other spurious components. The spectrum analyser shall be used to measure the power of any intermodulation component occurring at offsets equal to or less than 10 MHz from the carrier frequency. The test shall be repeated with the T3 signal generator frequency set to 5 MHz above, 500 kHz below and 5 MHz below the frequency of the transmitter under test.

The transmitter shall be set to produce 4-QAM modulation. This test shall be performed (where supported) at 25 kHz, 50 kHz, 100 kHz, and 150 kHz channel bandwidths.

8.8.1 MS Transmitter intermodulation attenuation

The signal generator level shall be set to deliver at the antenna connector of the transmitter under test an interfering signal (T3) at a power level 50 dB below the transmitter transmit level.

8.8.2 BS Transmitter intermodulation attenuation

The signal generator level shall be set to deliver at the antenna connector of the transmitter under test an interfering signal (T3) at a power level 30 dB below the transmitter transmit level.

8.8.3 Intra BS transmitter intermodulation attenuation

In the case of intra BS intermodulation, the individual transmitters shall be set to their nominal power levels and test signal T3 shall be switched off.

9 Methods of measurement for receiver parameters

9.1 General

Unless otherwise stated the equipment under test shall be operated in either the non-transmit state or the non-active transmit state.

9.2 Nominal error rates for phase modulation

9.2.0 Test conditions

The test shall be carried out under normal test conditions specified in clause 6. A test configuration as presented in clause 5.1 should be applied. The equipment under test shall be connected to the test system via its antenna connector.

NOTE: There are no nominal error rates for QAM.

9.2.1 MS nominal error rate

- a) The MS is set up to receive a T1 signal with channel type 1 burst in the middle radio frequency channel of the MS receive band. The propagation simulator function is set to TU50, defined in ETSI EN 300 392-2 [1], clause 6.8.3. The test system shall transmit test signal T1 such that the power level at the antenna connector of the MS is -85 dBm.
- b) At the test connector the error events in the received data shall be captured and the appropriate BER shall be calculated (refer to clause A.2).
- c) Step b) shall be repeated for all test cases (where supported) defined in clause 7.2.2.

9.2.2 BS nominal error rate

- a) The BS shall operate in its normal mode and shall transmit on timeslot 1 of frame 18 a synchronization burst containing BNCH/T information. The BNCH/T is used to indicate which channel type the BS expects the test system to send on timeslot 1 of the corresponding uplink channel in frames 1 to 18. A BS in continuous mode shall in time slots 1 to 4 of frames 1 to 17 and time slots 2 to 4 of frame 18, send a channel type 1 signal. For a discontinuous BS a channel type 1 signal shall be sent on timeslot 1 of frames 1 to 17 only.
- b) The BS is set up to receive a T1 signal with channel type 7 burst in the middle radio frequency channel of the BS receive band. The propagation simulator function is set to TU50, defined in ETSI EN 300 392-2 [1], clause 6.8.3. The test system shall transmit test signal T1 such that the power level at the antenna connector of the BS is -85 dBm.
- c) At the test connector the error events in the received data shall be captured and the appropriate BER shall be calculated (refer to clause A.2).
- d) Step b) shall be repeated for all test cases (where supported) defined in clause 7.2.2.

9.3 Reference sensitivity performance

9.3.0 Test conditions

The test shall be carried out under normal and where applicable extreme (LTLV, HTHV) test conditions specified in clause 6. A test configuration as presented in clause 5.1 should be applied. The equipment shall be connected to the test system via its antenna connector.

9.3.1 MS reference sensitivity performance for phase modulation

- a) Using test signal T1 the MS is set up to receive one of the logical channels defined in clause 7.2.3.2. The propagation simulator function shall be set according to clause 7.2.3.2. The test system shall provide the test signal T1, under normal test conditions, at a power level of -103 dBm.
- b) At the test connector the error events in the received data shall be captured and the appropriate error rate shall be calculated.
- c) Step b) shall be repeated for all test cases defined in clause 7.2.3.2.

In order to reduce test time, only the MS receiver sensitivity test using channel type 2, shall be conducted under both normal and extreme test conditions. Under extreme test conditions the test system shall provide the test signal T1, at a power level of -97 dBm. Channel type 2 receiver sensitivity measurements shall also be repeated in the highest, middle and lowest channels of the receive band. In all other MS test cases the receiver sensitivity test shall only be performed in the middle channel of the receive band under normal conditions.

9.3.2 BS reference sensitivity performance for phase modulation

- a) Using the test set-up outlined in clause 9.2.2 the BS shall be set up to receive one of the logical channels defined in clause 7.2.3.2. The test system shall provide the test signal T1 at a power level of -106 dBm:
 - In order to reduce test time, only the BS receiver sensitivity test using channel type 8, shall be conducted under both normal and extreme test conditions. Under extreme test conditions the test system shall provide the test signal, at a power level of -100 dBm. Channel type 8 receiver sensitivity measurements shall also be repeated in the highest, middle and lowest channels of the receive band. In all other BS test cases the receiver sensitivity test shall only be performed in the middle channel of the receive band under normal conditions.
- b) At the test connector the error events in the received data shall be captured and the appropriate error rate shall be calculated.
- c) Step b) shall be repeated for all test cases defined in clause 7.2.3.2.

9.3.3 MS reference sensitivity performance for QAM

- a) Using the test set-up described in clause 5.2.1.3 for QAM MS test receive mode, the MS is set up to receive one of the logical channels defined in clause 7.2.3.3. The propagation simulator function shall be set according to clause 7.2.3.3. The test system shall provide the test signal T4 at a power level based on the modulation type and channel bandwidth from clause 7.2.3.3.
- b) At the test connector the error events in the received data shall be captured and the appropriate error rate shall be calculated.
- c) Step b) shall be repeated (where supported) for all test cases defined in clause 7.2.3.3.

9.3.4 BS reference sensitivity performance for QAM

- a) Using the test set-up described in clause 5.2.1.4 for QAM BS test receive mode, the BS shall be set up to receive one of the logical channels defined in clause 7.2.3.3. The propagation simulator function shall be set according to clause 7.2.3.3. The test system shall provide the test signal T4 at a power level based on the modulation type and channel bandwidth from clause 7.2.3.3.
- b) At the test connector the error events in the received data shall be captured and the appropriate error rate shall be calculated.
- c) Step b) shall be repeated (where supported) for all test cases defined in clause 7.2.3.3.

9.3.5 PUEM performance

The PUEM performance of the receiver under test at reference sensitivity shall be measured, the test cases and conditions are detailed in the PUEM test table in clause A.2. The receiver under test shall provide along with the recovered data a message error flag at the test connector. The test system shall record those instances when a message error occurred, but the message error flag was not set. Following the completion of PUEM testing on the equipment, the test system shall generate a PUEM figure for each test case.

9.4 Reference interference performance

9.4.0 Test conditions

The tests shall be carried out under normal and in the case of adjacent channel interference, also extreme (LTLV, HTHV) test conditions specified in clause 6. A test configuration as presented in clause 5.1 should be applied. The equipment shall be connected to the test system.

9.4.1 MS reference interference performance for phase modulation

- a) The MS is set up to receive one of the logical channels defined for co-channel interference in clause 7.2.4.2 on a radio frequency channel in the middle of the MS receive band. The propagation simulator functions (for wanted and unwanted signals) shall be set according to clause 7.2.4.2. The test system shall provide the test signal T1 (wanted signal at the nominal frequency of the MS receiver) with a power level of -85 dBm at the antenna connector of the MS.
- b) The interfering signal source shall provide the phase modulated test signal T2 (unwanted signal) at the nominal frequency of the MS receiver and with a power level of -104 dBm at the antenna connector of the MS.
- c) At the test connector the error events in the received data shall be captured and the appropriate error rate calculated.
- d) Step c) shall be repeated for all co-channel interference test cases defined in clause 7.2.4.2.
- e) The test system shall provide the wanted test signal T1 with a power level of -100 dBm (normal test conditions) or -94 dBm (extreme test conditions). The interfering signal source shall be set to provide the unwanted phase modulated test signal T2 at the frequency offsets of ± 25 kHz from the nominal frequency of the MS receiver and with a power level of -60 dBm (normal) or -64 dBm (extreme).
- f) Step c) shall be repeated for all adjacent channel interference test cases defined in clause 7.2.4.2.

9.4.2 BS reference interference performance for phase modulation

- a) Using the test set-up outlined in clause 9.2.2 the BS shall be set up to receive one of the logical channels defined for co-channel interference in clause 7.2.4.2. on a radio frequency channel in the middle of the BS receive band. The propagation simulator functions (for wanted and unwanted signals) shall be set according to clause 7.2.4.2. The test system shall provide the test signal T1 (wanted signal at the nominal frequency of the BS receiver) with a power level of -85 dBm at the antenna connector of the BS.
- b) The interfering signal source shall provide the phase modulated test signal T2 (unwanted signal) at the nominal frequency of the BS receiver and with a power level of -104 dBm at the antenna connector of the BS.
- c) At the test connector the error events in the received data shall be captured and the appropriate error rate calculated.
- d) Step c) shall be repeated for all co-channel interference test cases defined in clause 7.2.4.2.
- e) The test system shall provide the wanted test signal at a power level of -103 dBm (normal test conditions) or -97 dBm (extreme test conditions). The interfering signal source shall be set to provide the unwanted phase modulated test signal T2 at the frequency offsets of ± 25 kHz from the nominal frequency of the BS receiver and with a power level of -58 dBm (normal) or -62 dBm (extreme) for frequencies less than 700 MHz, and -63 dBm (normal) or -67 dBm (extreme) for frequencies above 700 MHz.

- f) Step c) shall be repeated for all adjacent channel interference test cases defined in clause 7.2.4.2.

9.4.3 MS reference interference performance for QAM

- a) Using the test set-up described in clause 5.2.1.3 for QAM MS test receive mode, the MS shall be set up to receive one of the logical channels defined for co-channel interference in clause 7.2.4.3 on a radio frequency channel in the middle of the MS receive band. The propagation simulator functions (for wanted and unwanted signals) shall be set according to clause 7.2.4.3. The test system shall provide the test signal T4 (wanted signal at the nominal frequency of the MS receiver) with the power level indicated in clause 7.2.4.3 at the antenna connector of the MS.
- b) The interfering signal source shall provide the QAM modulated test signal T2 (unwanted signal) at the nominal frequency of the MS receiver and with the power level indicated in clause 7.2.4.3 at the antenna connector of the MS. The bandwidth and modulation shall be the same as the test signal T4.
- c) At the test connector the error events in the received data shall be captured and the appropriate error rate calculated.
- d) Step c) shall be repeated (where supported) for all co-channel interference test cases defined in clause 7.2.4.3.
- e) The test system shall provide the wanted test signal T4 with the power level indicated in clause 7.2.4.3. The interfering signal source shall be set to provide the phase modulated test signal T2 (unwanted signal) at the frequency offset and power level indicated in clause 7.2.4.3.
- f) Step c) shall be repeated (where supported) for all adjacent channel interference test cases defined in clause 7.2.4.3.

9.4.4 BS reference interference performance for QAM

- a) Using the test set-up described in clause 5.2.1.4 for QAM BS test receive mode, the BS shall be set up to receive one of the logical channels defined for co-channel interference in clause 7.2.4.3 on a radio frequency channel in the middle of the BS receive band. The propagation simulator functions (for wanted and unwanted signals) shall be set according to clause 7.2.4.3. The test system shall provide the test signal T4 (wanted signal at the nominal frequency of the BS receiver) with the power level indicated in clause 7.2.4.3 at the antenna connector of the BS.
- b) The interfering signal source shall provide the QAM modulated test signal T2 (unwanted signal) at the nominal frequency of the BS receiver and with the power level indicated in clause 7.2.4.3 at the antenna connector of the BS. The bandwidth and modulation shall be the same as the test signal T4.
- c) At the test connector the error events in the received data shall be captured and the appropriate error rate calculated.
- d) Step c) shall be repeated (where supported) for all co-channel interference test cases defined in clause 7.2.4.3.
- e) The test system shall provide the wanted test signal at the power level indicated in clause 7.2.4.3. The interfering signal source shall be set to provide the unwanted phase modulated test signal T2 (unwanted signal) at the frequency offsets and power level indicated in clause 7.2.4.3.
- f) Step c) shall be repeated (where supported) for all adjacent channel interference test cases defined in clause 7.2.4.3.

9.5 Blocking characteristics

9.5.0 Test conditions

The test shall be carried out under normal test conditions specified in clause 6. The test configuration presented in clause 5.1 is applied. The error rate indication scheme used in clauses 9.3 and 9.4 may be employed. All propagation simulator functions are set to "static". The equipment shall be connected to the test system.

9.5.1 MS blocking for phase modulation

- a) The MS is set up to receive a T1 channel type 1 signal (i.e. TCH/7,2) on a radio frequency channel in the middle of the MS receive band. The test system shall provide the wanted test signal T1 at a power level of -109 dBm at the antenna connector of the MS.
- b) The interfering signal source shall provide the test signal T3 (unmodulated unwanted signal) at frequency offsets of approximately ± 1 MHz, ± 2 MHz, ± 5 MHz and ± 10 MHz from the nominal frequency of the MS receiver at a power level of -25 dBm. The actual values of the offset frequencies shall be adjusted in steps of 25 kHz such that they do not coincide with the frequencies of spurious response to be tested in clause 9.6.
- c) For each of the offset frequencies chosen in step b) the bit error rate shall be indicated.

9.5.2 BS blocking for phase modulation

- a) Using the test set-up outlined in clause 9.2.2 the BS shall be set up to receive a T1 channel type 7, on a radio frequency channel in the middle of the BS receive band. The test system shall provide the wanted test signal T1 at a power level of -112 dBm at the antenna connector of the BS.
- b) The interfering signal source shall provide the test signal T3 (unmodulated unwanted signal) at frequency offsets of ± 1 MHz, ± 2 MHz, ± 5 MHz and ± 10 MHz from the nominal frequency of the BS receiver at a power level of -25 dBm. The actual values of the offset frequencies shall be adjusted in steps of 25 kHz such that they do not coincide with the frequencies of spurious response to be tested in clause 9.6.
- c) For each of the offset frequencies chosen in step b) the bit error rate shall be indicated.

9.5.3 MS blocking for QAM

- a) Using the test set-up described in clause 5.2.1.3 for QAM MS test receive mode, the MS shall be set up to receive a T4 channel type 27 signal (i.e. SCH-Q/D) on a radio frequency channel in the middle of the MS receive band. The test system shall provide the wanted test signal T4 at the power level indicated in clause 7.2.5.3 at the antenna connector of the MS.
- b) The interfering signal source shall provide the test signal T3 (unmodulated unwanted signal) at frequency offsets and power levels from clause 7.2.5.3. The power level of the interfering signal is related to the frequency offset of the interferer and is given in tables 7.28, 7.29, 7.30, and 7.31. The actual values of the offset frequencies shall be adjusted in steps of 25 kHz such that they do not coincide with the frequencies of spurious response to be tested in clause 9.6.
- c) For each of the offset frequencies chosen in step b) the bit error rate shall be indicated.
- d) This test should be repeated (where supported) for each of the test cases in clause 7.2.5.3 at each of 4-QAM, 16-QAM and 64-QAM (where supported).

9.5.4 BS blocking for QAM

- a) Using the test set-up described in clause 5.2.1.4 for QAM BS test receive mode, the BS shall be set up to receive a T4 channel type 26 signal (i.e. SCH-Q/U), on a radio frequency channel in the middle of the BS receive band. The test system shall provide the test signal T4 (wanted signal at the nominal frequency of the BS receiver) with the power level indicated in clause 7.2.5.3 at the antenna connector of the BS.
- b) The interfering signal source shall provide the test signal T3 (unmodulated unwanted signal) at frequency offsets and power levels from clause 7.2.5.3. The power level of the interfering signal is related to the frequency offset of the interferer and is given in tables 7.28 to 7.31. The actual values of the offset frequencies shall be adjusted in steps of 25 kHz such that they do not coincide with the frequencies of spurious response to be tested in clause 9.6.
- c) For each of the offset frequencies chosen in step b) the bit error rate shall be indicated.
- d) This test should be repeated (where supported) for each of the test cases in clause 7.2.5.3.

9.6 Spurious response rejection

9.6.0 Test conditions

The tests shall be carried out under the normal test conditions specified in clause 6. The tests shall be performed in the middle radio frequency channel only.

9.6.1 Phase Modulation

- a) The same test configuration and conditions as in clause 9.5 with exceptions are applied. The frequency of the interfering signal is set to the frequencies as defined in clause A.1, and the power level of the interfering signal is set to the level specified in ETSI EN 300 392-2 [1], table 6.21: Blocking levels of the receiver. For each interfering frequency the error rate shall be measured. An interfering frequency where the blocking bit error rate limits in clause A.2 is not fulfilled is defined as a spurious response frequency.
- b) For each spurious response frequency the error rate shall be measured with a power level of the interfering signal of -45 dBm.
- c) For each of the spurious response frequencies found in step a) the frequency and bit error rate shall be indicated.

9.6.2 QAM

- a) The same test configuration and conditions as in clause 9.5 with exceptions are applied. The frequency of the interfering signal is set to the frequencies as defined in clause A.1, and the power level of the interfering signal is set to the level specified in ETSI EN 300 392-2 [1], tables 6.22 to 6.25. For each interfering frequency the error rate shall be measured. An interfering frequency where the blocking bit error rate limits in clause A.2 is not fulfilled is defined as a spurious response frequency.
- b) For each spurious response frequency the error rate shall be measured with a power level of the interfering signal of -45 dBm.
- c) For each of the spurious response frequencies found in step a) the frequency and bit error rate shall be indicated.
- d) This test should be repeated (where supported) for each of the test cases in clause 7.2.6.3.

9.7 Intermodulation response rejection

9.7.0 Test conditions

The test shall be carried out under normal test conditions specified in clause 6. The test configuration presented in clause 5.1 is applied. The error rate indication scheme used in clauses 9.2 to 9.4 may be employed. All propagation simulator functions are set to "static". The equipment under test shall be connected to the test system.

9.7.1 MS intermodulation response rejection for phase modulation

- a) The MS is set up to receive a T1 channel type 1 signal (i.e. TCH/7,2) on a radio frequency channel f_0 in the middle of the MS receive band. The test system shall provide the wanted test signal T1 at a power level of -109 dBm at the antenna connector of the MS.
- b) The unmodulated interfering signal source shall provide the test signal T3 (unmodulated unwanted signal) at frequency ($f_1 = f_0 - 200$ kHz) and with a power level of -47 dBm. The modulated interfering signal source shall provide the phase modulated test signal T2 (modulated unwanted signal) at frequency ($f_2 = f_0 - 400$ kHz) and with a power level of -47 dBm. Both unwanted power levels refer to the antenna connector of the MS.
- c) The error events in the received data shall be captured and the appropriate error rate shall be calculated.

- d) Step c) shall be repeated with the unwanted signal frequencies set to ($f_1 = f_0 + 200$ kHz) and ($f_2 = f_0 + 400$ kHz).

9.7.2 BS intermodulation response rejection for phase modulation

- a) Using the test set-up outlined in clause 9.2.2 the BS shall be set up to receive a T1 channel type 7, on a radio frequency channel f_0 in the middle of the BS receive band. The test system shall provide the wanted test signal T1 at a power level of -112 dBm at the antenna connector of the BS.
- b) The unmodulated interfering signal source shall provide the test signal T3 (unmodulated unwanted signal) at frequency ($f_1 = f_0 - 200$ kHz) and with a power level of -47 dBm. The modulated interfering signal source shall provide the phase modulated test signal T2 (modulated unwanted signal) at frequency ($f_2 = f_0 - 400$ kHz) and with a power level of -47 dBm. Both unwanted power levels refer to the antenna connector of the BS.
- c) The error events in the received data shall be captured and the appropriate error rate shall be calculated.
- d) Step c) shall be repeated with the unwanted signal frequencies set to ($f_1 = f_0 + 200$ kHz) and ($f_2 = f_0 + 400$ kHz).

9.7.3 MS intermodulation response rejection for QAM

- a) Using the test set-up described in clause 5.2.1.3 for QAM MS test receive mode, the MS shall be set up to receive a T4 channel type 27 signal (i.e. SCH-Q/D) on a radio frequency channel f_0 in the middle of the MS receive band. The test system shall provide the wanted test signal T4 at the power level indicated in clause 7.2.7.2 at the antenna connector of the MS. The modulation should be set to 4-QAM and the bandwidth should be set to 25 kHz.
- b) The unmodulated interfering signal source shall provide the test signal T3 (unmodulated unwanted signal) at frequency ($f_1 = f_0 - f_x$) and with a power level of -47 dBm. The modulated interfering signal source shall provide the phase modulated test signal T2 (modulated unwanted signal) at frequency ($f_2 = f_0 - 2f_x$) and with a power level of -47 dBm. The value f_x comes from table 7.33. Both unwanted power levels refer to the antenna connector of the MS.
- c) The error events in the received data shall be captured and the appropriate error rate shall be calculated.
- d) Step c) shall be repeated with the unwanted signal frequencies set to ($f_1 = f_0 + f_x$) and ($f_2 = f_0 + 2f_x$).
- e) Steps b), c), and d) should be repeated (where supported) using 50 kHz, 100 kHz, and 150 kHz channel bandwidths for the wanted signal T4.

9.7.4 BS intermodulation response rejection for QAM

- a) Using the test set-up described in clause 5.2.1.4 for QAM BS test receive mode, the BS shall be set up to receive a T4 channel type 26 signal (i.e. SCH-Q/U), on a radio frequency channel f_0 in the middle of the BS receive band. The test system shall provide the wanted test signal T4 at a power level indicated in clause 7.2.7.2 at the antenna connector of the BS. The modulation should be set to 4-QAM and the bandwidth should be set to 25 kHz.
- b) The unmodulated interfering signal source shall provide the test signal T3 (unmodulated unwanted signal) at frequency ($f_1 = f_0 - f_x$) and with a power level of -47 dBm. The modulated interfering signal source shall provide the phase modulated test signal T2 (modulated unwanted signal) at frequency ($f_2 = f_0 - 2f_x$) and with a power level of -47 dBm. Both unwanted power levels refer to the antenna connector of the BS. The value f_x comes from table 7.33.
- c) The error events in the received data shall be captured and the appropriate error rate shall be calculated.
- d) Step c) shall be repeated with the unwanted signal frequencies set to ($f_1 = f_0 + f_x$) and ($f_2 = f_0 + 2f_x$).
- e) Steps b), c), and d) should be repeated (where supported) using 50 kHz, 100 kHz, and 150 kHz channel bandwidths for the wanted signal T4.

9.8 Unwanted emissions

The test shall be carried out under normal test conditions specified in clause 6.

The equipment shall be connected to the test system via its antenna connector. The equipment shall be in receive mode in the non-transmit state. For equipment only capable of operating at frequencies below 470 MHz, the test system shall measure the peak power emitted by the equipment in the frequency range 9 kHz to 4 GHz. For equipment capable of operating at frequencies above 470 MHz, the test system shall measure the peak power emitted by the equipment in the frequency range 9 kHz to 12,75 GHz. Discrete spurious emissions shall be measured as a peak power level of any discrete signal delivered to a spectrum analyser suitably connected to the antenna port of the equipment (defined in clause B.1.3). The resolution bandwidth of the spectrum analyser shall be 100 kHz for frequencies up to 1 GHz and 1 MHz for frequencies above 1 GHz. When measuring in the frequency range below 3 MHz the measurement bandwidth shall be reduced according to specifications of the spectrum analyser. The test shall be performed on the middle radio frequency channel only of the equipment's receive band.

9.9 Unwanted radiated emissions

The test shall be carried out under normal test conditions specified in clause 6. The test shall be performed with the equipment in receive mode in the non-transmit state in the middle radio frequency channel only.

Using the measurement arrangement shown in ETSI EN 300 113-1 [3], figure 9, on a test site fulfilling the requirements of ETSI EN 300 113-1 [3], clause A.2, the MS or BS under test shall be placed at the specified height on the support. For BS testing, the test shall be carried out using an artificial antenna which shall be a substantially non-reactive non-radiating load of 50 Ω connected to the antenna connector. For MS testing, the test may be carried out using an artificial antenna which shall be a substantially non-reactive non-radiating load of 50 Ω connected to the antenna connector, or the test may be carried out with a non-radiating cable connecting the MS antenna connector to the test system, located outside the test site, in order to provide the T1 signal to the MS.

The MS or BS shall be operated in test receive mode in the non-transmit state. Emissions from the cabinet of the MS or BS under test shall be received by the test antenna connected to the test receiver.

The radiation of any discrete spurious emissions in the range 30 MHz to 4 GHz, occurring at offsets equal to or greater than 100 kHz from the carrier frequency, shall be measured over 200 bursts as the peak power level of any discrete signal delivered to the test receiver connected to the test antenna. The resolution bandwidth of the measuring instrument shall be the smallest bandwidth available which is greater than the spectral width of the spurious component being measured. This shall be considered to be achieved when the next highest bandwidth causes less than 1 dB increase in amplitude.

At each frequency at which a discrete spurious emission is detected, the MS or BS under test shall be rotated to obtain maximum response and the effective radiated power of that component determined by a substitution measurement, using the measurement arrangement of ETSI EN 300 113-1 [3], figure 10, where the substitution signal is T3.

The measurements shall be repeated with the test antenna in the orthogonal polarization plane.

A pre-scan may be performed to identify any potential discrete spurious emissions, using a suitable technique.

10 Methods of measurement for transmitter/receiver parameters

10.1 Modulation accuracy

10.1.0 Test conditions

The test shall be carried out at maximum nominal power only under normal test conditions specified in clause 6. The test configuration presented in clause 5.1 is applied. The sampling system in clause B.1.2 shall be employed.

10.1.1 MS modulation accuracy for phase modulation

This measurement shall be performed on a Normal Uplink Burst with Normal Training Sequence 1 (to exclude any BLCH transmissions), defined in ETSI EN 300 392-2 [1], clause 9. The MS shall be connected to the test system. The test system shall transmit test signal T1. Test signal T1 BNCH/T parameters and level as detailed in test case 1 of clause 8.1.1.1 a) shall be used. All T1 levels are referenced to the antenna connector of the MS.

The MS shall be set to test receive mode for a period of at least 5 s in which it will decode BSCH and BNCH/T information and measure T1 signal strength. The MS shall then be set to test transmit mode. The modulation accuracy shall be tested by measuring the vector error magnitude as specified in clause 10.1.3.

This test shall be repeated with a $\pi/8$ -D8PSK modulated T1 signal type (where supported) as detailed in clause 8.1.1.1 d).

10.1.2 BS modulation accuracy for phase modulation

This measurement shall be performed on a Normal Downlink Bursts with Normal Training Sequence 1 (to exclude any BLCH transmissions), defined in ETSI EN 300 392-2 [1], clause 9. The BS shall be connected to the test system. The test procedure detailed in clause 8.1.1.2 a) shall be used. The modulation accuracy shall be tested by measuring the vector error magnitude as specified in clause 10.1.3.

This test shall be repeated with a $\pi/8$ -D8PSK modulated T1 signal type (where supported) as detailed in clause 8.1.1.2 e).

10.1.3 Vector error magnitude at symbol time for phase modulation

- a) The sampling system shall capture a representation of the transmit burst's vector error at sampling times t_k (symbol by symbol) where t_k is the symbol time corresponding to the k^{th} symbol. For each symbol the sampling system shall compute the vector error $Z'(k) - S(k)$ defined in ETSI EN 300 392-2 [1], clause 6.6.1.2, where $Z'(k)$ is the normalized modulation symbol transmitted by the MS and $S(k)$ is the modulation symbol which would be transmitted by an ideal MS. The sampling system shall calculate the RMS vector error RMSVE for all symbols of the burst as defined in ETSI EN 300 392-2 [1], clause 6.6.1.2. The sampling system shall also calculate the peak vector error magnitude $|Z'(k)-S(k)|$ and the residual carrier magnitude C_0 as defined in ETSI EN 300 392-2 [1], clause 6.6.1.2 for each symbol of the burst and shall calculate the mean residual carrier magnitude $\langle C_0 \rangle$ averaged over all values C_0 of the burst.
- b) The procedure described in step a) shall be repeated for 200 bursts.
- c) The procedures described in steps a) and b) shall be performed on the lowest, highest and middle radio frequency channel in the transmit band.

10.1.4 MS modulation accuracy for QAM

The MS shall be connected to the test system. The test system shall transmit test signal T4 as detailed in clause 8.1.2.1 a). All T4 levels are referenced to the antenna connector of the MS.

The MS shall be set to test receive mode for a period of at least 5 s in which it will decode BSCH and BNCH/T information and measure T4 signal strength. The MS shall then be set to test transmit mode. The modulation accuracy shall be tested by measuring the vector error magnitude as specified in clause 10.1.6.

This test shall be performed (where supported) using 4-QAM, 16-QAM, and 64-QAM modulation and at 25 kHz, 50 kHz, 100 kHz, and 150 kHz channel bandwidths.

10.1.5 BS modulation accuracy for QAM

The BS shall be connected to the test system and shall be set to test transmit mode using a QAM normal downlink burst type. The BS shall transmit at the BS maximum nominal output power level. The modulation accuracy shall be tested by measuring the vector error magnitude as specified in clause 10.1.6.

This test shall be performed (where supported) using 4-QAM, 16-QAM, and 64-QAM modulation and at 25 kHz, 50 kHz, 100 kHz, and 150 kHz channel bandwidths.

10.1.6 Vector error magnitude at symbol time for QAM

- a) The sampling system shall capture a representation of the transmit burst's vector error at sampling times t_k (symbol by symbol) where t_k is the symbol time corresponding to the k^{th} symbol of the associated sub-carrier. For each symbol the sampling system shall compute the vector error $Z'_m(k) - S_m(k)$ defined in ETSI EN 300 392-2 [1], clause 6.7.1.2, where $Z'_m(k)$ is the normalized modulation symbol transmitted by the MS for an individual sub-carrier and $S_m(k)$ is the modulation symbol which would be transmitted by an ideal MS for an individual sub-carrier. The sampling system shall calculate the RMS vector error RMSVE for all symbols of the burst as defined in ETSI EN 300 392-2 [1], clause 6.7.1.2.
- b) The procedure described in step a) shall be repeated for 200 bursts.
- c) The procedures described in steps a) and b) shall be performed on the lowest, highest and middle radio frequency channel in the transmit band.

10.2 Carrier frequency accuracy

10.2.0 Test set-up

The test set-up shall be according to clause 10.1.

10.2.1 MS carrier frequency accuracy for phase modulation

The sampling system shall be synchronized to the internal timing reference of the test system. The MS shall adjust its frequency by means of BSCH signals received from the test system. The MS shall be connected to the test system and the test system shall transmit test signal T1. Test signal T1 level and BNCH/T parameters as detailed in test case 1 of clause 8.1.1.1 a) shall be used. All T1 levels are referenced to the antenna connector of the MS.

The MS shall be set to test receive mode for a period of at least 5 s in which it will decode BSCH and BNCH/T information and measure T1 signal strength. The MS shall then be set to test transmit mode and the input level applied to the MS shall be the static reference sensitivity level.

- a) The sampling system shall capture a representation of the MS transmit burst's modulation symbol $Z(k)$ at sampling times t_k (symbol by symbol) where t_k is the symbol time corresponding to the k^{th} symbol. For each symbol the sampling system shall measure the phase rotation θ which is caused by the frequency difference between the MS and the sampling system, as defined in ETSI EN 300 392-2 [1], clause 6. The sampling system shall calculate the frequency error df for the burst as follows:

$$df = 1/(2\pi T SNmax) \sum_{k=1}^{SNmax} \theta(k)$$

where df is expressed in Hz, T is the symbol duration in seconds, $\theta(k)$ is expressed in radians, and $SNmax$ is the number of symbols in a burst.

- b) The procedure described in step a) shall be repeated for 200 bursts.
- c) The procedures described in steps a) and b) shall be performed on the lowest, highest and middle radio frequency channel in the MS transmit band.
- d) This test shall be repeated with a $\pi/8$ -D8PSK modulated T1 signal type (where supported) as detailed in clause 8.1.1.1 d).

10.2.2 BS carrier frequency accuracy for phase modulation

The BS shall be connected to the test system. The test procedure detailed in clause 8.1.1.2 a) shall be used. The carrier frequency accuracy shall be tested as follows:

- a) The sampling system shall capture a representation of the BS transmit burst's modulation symbol $Z(k)$ at sampling times t_k (symbol by symbol) where t_k is the symbol time corresponding to the k^{th} symbol. For each symbol the sampling system shall measure the phase rotation θ which is caused by the frequency difference between the BS and the sampling system, as defined in ETSI EN 300 392-2 [1], clause 6. The sampling system shall calculate the frequency error df for the burst as follows:

$$df = 1/(2\pi T SN_{max}) \sum_{k=1}^{SN_{max}} \theta(k)$$

where df is expressed in Hz, T is the symbol duration in seconds, $\theta(k)$ is expressed in radians, and SN_{max} is the number of symbols in a burst.

- b) The procedure described in step a) shall be repeated for 200 bursts.
- c) If applicable the procedures described in steps a) and b) shall be performed on the lowest, highest and middle radio frequency channel in the BS transmit band.
- d) This test shall be repeated with a $\pi/8$ -D8PSK modulated T1 signal type (where supported) as detailed in clause 8.1.1.2 e).

10.2.3 MS carrier frequency accuracy for QAM

The MS shall be connected to the test system. The test system shall transmit test signal T4 as detailed in clause 8.1.2.1 a). All T4 levels are referenced to the antenna connector of the MS.

The MS shall be set to test receive mode for a period of at least 5 s in which it will decode BSCH and BNCH/T information and measure T4 signal strength. The MS shall then be set to test transmit mode.

- a) The sampling system shall capture a representation of the transmit burst's vector error at sampling times t_k (symbol by symbol) where t_k is the symbol time corresponding to the k^{th} symbol of the associated sub-carrier. For each symbol the sampling system shall measure the phase rotation θ which is caused by the frequency difference between the MS and the sampling system, as defined in ETSI EN 300 392-2 [1], clause 6.7.1.2. The sampling system shall calculate the frequency error df for the burst as follows:

$$df = 1/(2\pi T SN_{max}) \sum_{k=1}^{SN_{max}} \theta(k)$$

where df is expressed in Hz, T is the symbol duration in seconds, $\theta(k)$ is expressed in radians, and SN_{max} is the number of symbols in a burst.

- b) The procedure described in step a) shall be repeated for 200 bursts.
- c) The procedures described in steps a) and b) shall be performed on the lowest, highest and middle radio frequency channel in the MS transmit band.
- d) This test shall be performed (where supported) using 4-QAM, 16-QAM, and 64-QAM modulation and at 25 kHz, 50 kHz, 100 kHz, and 150 kHz channel bandwidths.

10.2.4 BS carrier frequency accuracy for QAM

The BS shall be connected to the test system. The test procedure detailed in clause 8.1.2.2 a) shall be used. The carrier frequency accuracy shall be tested as follows:

- a) The sampling system shall capture a representation of the BS transmit burst's modulation symbol $Z(k)$ at sampling times t_k (symbol by symbol) where t_k is the symbol time corresponding to the k^{th} symbol of the associated sub-carrier. For each symbol the sampling system shall measure the phase rotation θ which is caused by the frequency difference between the BS and the sampling system, as defined in ETSI EN 300 392-2 [1], clause 6.7.1.2. The sampling system shall calculate the frequency error df for the burst as follows:

$$df = 1/(2\pi T SN_{max}) \sum_{k=1}^{SN_{max}} \theta(k)$$

where df is expressed in Hz, T is the symbol duration in seconds, $\theta(k)$ is expressed in radians, and SN_{max} is the number of symbols in a burst.

- b) The procedure described in step a) shall be repeated for 200 bursts.
- c) If applicable the procedures described in steps a) and b) shall be performed on the lowest, highest and middle radio frequency channel in the BS transmit band.
- d) This test shall be performed (where supported) using 4-QAM, 16-QAM, and 64-QAM modulation and at 25 kHz, 50 kHz, 100 kHz, and 150 kHz channel bandwidths.

10.3 MS receiver performance for synchronization acquisition

10.3.1 CA MS receiver performance for synchronization burst acquisition

The test shall be carried out under normal test conditions specified in clause 6. A test configuration as presented in clause 5.1 may be applied. The propagation simulator function (wanted signal only) shall be set to TU50 for class B receiver testing and HT200 for class A, class D, and class E receiver testing, defined in ETSI EN 300 392-2 [1], clause 6.8.3. The test system shall transmit discontinuous synchronization bursts (channel type 13) on the middle frequency of the receive band, at a power level of -103 dBm. Before starting the synchronization burst acquisition performance test the MS shall be switched off for a period of at least 60 s, following power on the MS receiver shall be fixed to the middle frequency channel of the receive band, i.e. no scanning required. The MS will now attempt to detect the synchronization burst and decode the BSCH and BNCH/T information. A special T1_T4_burst_type field contained in the BNCH/T, is used to place the MS into synchronization acquisition test mode. During this period the MS may perform some frequency offset correction.

Following the first synchronization burst which is successfully detected and decoded, the MS shall enter synchronization acquisition test mode, this shall be immediately indicated at the test connector to inform the test system that the MS is ready for the synchronization burst acquisition test.

Once in synchronization acquisition mode the MS shall continuously attempt to detect a synchronization burst and decode the BSCH information. Each successful decoding shall be indicated at the MS test connector.

The test system shall transmit 20 synchronization bursts and count the number of successful acquisitions and calculate the PACQ.

10.3.2 DA MS receiver performance for frequency correction burst acquisition

The test shall be carried out under normal test conditions specified in clause 6. A test configuration as presented in clause 5.1 may be applied. The propagation simulator function (wanted signal only) shall be TU50 or HT200, defined in ETSI EN 300 392-2 [1], clause 6.8.3. The test system shall transmit discontinuous frequency correction bursts (channel type 29) on the middle frequency of the receive band, at a power level of -108 dBm, -105 dBm, -102 dBm and -101 dBm for bandwidths of 25 kHz, 50 kHz, 100 kHz and 150 kHz respectively. Before starting the synchronization burst acquisition performance test the MS shall be switched off for a period of at least 60 s, following power on the MS receiver shall be fixed to the middle frequency channel of the receive band, i.e. no scanning required. The MS will now attempt to detect the frequency correction burst and decode the BSCH-Q/T information. A special T1_T4_burst_type field contained in the BSCH-Q/T, is used to place the MS into synchronization acquisition test mode. During this period the MS may perform some frequency offset correction.

Following the first frequency correction burst which is successfully detected and decoded, the MS shall enter synchronization acquisition test mode, this shall be immediately indicated at the test connector to inform the test system that the MS is ready for the frequency correction burst acquisition test.

Once in synchronization acquisition mode the MS shall continuously attempt to detect a frequency correction burst and decode the BSCH-Q/T information. Each successful decoding shall be indicated at the MS test connector.

The test system shall transmit 20 frequency correction bursts and count the number of successful acquisitions and calculate the PACQ.

10.4 MS Frame alignment performance

The test shall be carried out under normal test conditions specified in clause 6. A test configuration as presented in clause 5.1 may be applied. The training sequences transmitted by the test system shall be used as a timing reference during this test procedure. The MS shall be synchronized to the test system (in terms of frequency and time slot).

The test system shall transmit test signal T1 or T4 on a frequency in the middle of the MS receive band, at 3 dB below the dynamic reference sensitivity level, placing the MS into test transmit mode:

- a) For phase modulation testing, the propagation simulator function for phase modulation (T1, wanted signal only) is set to TU50 (class B) or HT200 (class A, class D, class E), defined in ETSI EN 300 392-2 [1], clause 6.8.3. For QAM testing, the test is repeated with the propagation simulator function for QAM (T4, wanted signal only) is set to TU50 and HT200, defined in ETSI EN 300 392-2 [1], clause 6.8.3.
- b) The Timing Delay (TD) of bursts transmitted by the test system shall be set to zero.
- c) The MS shall transmit normal uplink bursts in the radio frequency channel in the middle of the MS transmit band. The timing measurement unit (refer to clause B.1.7) shall compare the timing of each burst received from the MS with that of the slot timing of test signal T1 or T4. The timing measurement shall be repeated for 200 bursts.
- d) The test system shall increase the delay (TD) of its transmission in steps of 55,55 μ s (one $\pi/4$ -DQPSK symbol duration). After setting a new delay value (TD) a settling time of 10 s is required for the MS before starting the next timing measurement. The step c) above shall be repeated for TD values of 55,55 μ s, 111,11 μ s and 166,67 μ s (i.e. 1, 2 and 3 $\pi/4$ -DQPSK symbol durations).
- e) This test shall be performed for all phase modulation and QAM types supported.

10.5 MS link control

The test shall be carried out under normal test conditions specified in clause 6:

- a) The MS shall be connected to the test system. The test system shall transmit test signal T1 or T4. Test signal T1/T4 level and BNCH/T parameters as detailed in test case 1 in table 10.1 shall be used. All test signal levels are referenced to the antenna connector of the MS.

Table 10.1: Test Case

test case	T1 level (dBm)	Access_parameter (dBm)	MS_TXPWR_MAXCELL (dBm)	maximum power (dBm)
1	-80	-53	45	32,5
2	-65	-53	45	17,5
3	-50	-33	45	22,5

- The MS shall be set to test receive mode for a period of at least 5 s in which it will decode BSCH and BNCH/T information and measure T1/T4 signal strength. The MS shall then be set to test transmit mode.
- b) The sampling system shall capture a representation of the MS transmit burst's (excluding any CLCH transmissions) amplitude and timing (sampled at symbol rate at symbol time). The procedure shall be repeated for 200 bursts and the test system shall calculate the average power over the useful part of a burst as defined in ETSI EN 300 392-2 [1], further averaged over the 200 burst measurements.
- c) The steps a) and b) shall be repeated for the parameters detailed in test cases 2 and 3.
- d) The test shall be performed on the lowest, highest and middle radio frequency channels in the MS receive band.
- e) This test shall be performed for all phase modulation and QAM types and bandwidths supported.

The test scenario presented in figure 10.1 is applied. The propagation simulator function (wanted signal only) shall be set to TU50, defined in ETSI EN 300 392-2 [1], clause 6.8.3.

NOTE: The dynamic propagation condition TU50 is used in order to test implicitly the capability of the MS to perform averaged signal strength measurements under the "fading" reception conditions.

The test system shall know the maximum MS power.

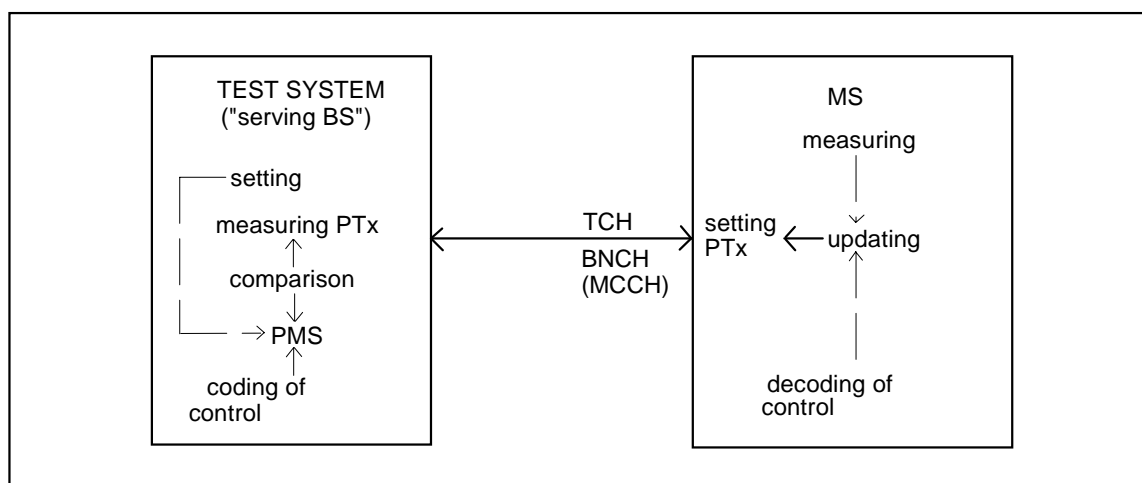

Figure 10.1: MS link control test scenario

11 Measurement uncertainty

11.0 Tolerances and uncertainties

The maximum acceptable uncertainty of measurement equipment is specified separately for each test, where appropriate. The measurement equipment shall enable the stimulus signals in the test case to be adjusted to within the specified tolerance, and the measurement to be made with an uncertainty not exceeding the specified values. All tolerances and uncertainties are absolute values, unless otherwise stated. All test case tolerances and measurement uncertainties are specified through the TETRA filter, refer to clause B.1.2.2, unless otherwise stated.

Clause 6, Test conditions:

- Temperature ± 2 °C (degrees Celsius)
- Relative Humidity ± 5 %
- DC Voltage $\pm 1,0$ %
- AC Voltage $\pm 1,5$ %

The above values shall apply unless the test environment is controlled and the specification for the control of the test environment specifies the uncertainty for the parameter.

11.1 Transmitter

Clause 8.1.1, MS Mean transmitted RF carrier power:

- Test case:
 - T1/T4 level $\pm 3,0$ dB
- Test requirement:
 - RF power $\pm 0,75$ dB

Clause 8.1.1, MS Transmitted RF carrier power versus time:

- Test case:
 - T1/T4 level $\pm 3,0$ dB
 - Inherent noise level:
 - RF power (L_{\min}) ≤ -80 dBc
- Test requirement:
 - RF power relative to 0 dB reference (0 dBc to -45 dBc) $\pm 1,0$ dB
 - RF power relative to 0 dB reference (< -45 dBc to -73 dBc) $\pm 1,5$ dB
 - Timing uncertainty (profile) $\pm 1/16$ symbol

Clause 8.1.2, BS Mean transmitted RF carrier power:

- Test case:
 - T1/T4 level $\pm 3,0$ dB
- Test requirement:
 - RF power $\pm 0,75$ dB

Clause 8.1.2, BS transmitted RF carrier power versus time:

- Test case:
 - T1/T4 level $\pm 3,0$ dB
- Inherent noise level:
 - RF power (L_{\min}) ≤ -50 dBc

- Test requirement:
 - RF power relative to 0 dB reference (0 dBc to -45 dBc) ±1,0 dB
 - RF power relative to 0 dB reference (< -45 dBc to -73 dBc) ±1,5 dB
 - Timing uncertainty (profile) ±1/16 symbol

Clause 8.2, Unwanted output power in non-active transmit state:

- Test case:
 - T1/T4 level ±3,0 dB
- Test requirement:
 - RF power relative to 0 dB reference (0 dBc to -45 dBc) ±1,0 dB
 - RF power relative to 0 dB reference (< -45 dBc to -73 dBc) ±1,5 dB
 - Inherent noise level ≤ -80 dBc

Clause 8.3, Adjacent channel power due to modulation:

- Test case:
 - T1/T4 level ±3,0 dB

Maximum residual adjacent channel level of the test system:

- For a 25 kHz channel:
 - Maximum level at frequency offset 25 kHz -70 dBc
 - Maximum level at frequency offset 50 kHz -80 dBc
 - Maximum level at frequency offset 75 kHz -80 dBc
- For a 50 kHz channel:
 - Maximum level at frequency offset 37,5 kHz -65 dBc
 - Maximum level at frequency offset 62,5 kHz -73 dBc
 - Maximum level at frequency offset 87,5 kHz -75 dBc
- For a 100 kHz channel:
 - Maximum level at frequency offset 62,5 kHz -73 dBc
 - Maximum level at frequency offset 87,5 kHz -75 dBc
 - Maximum level at frequency offset 112,5 kHz -70 dBc
- For a 150 kHz channel:
 - Maximum level at frequency offset 87,5 kHz -75 dBc
 - Maximum level at frequency offset 112,5 kHz -70 dBc
 - Maximum level at frequency offset 137,5 kHz -70 dBc
- Test requirement:
 - RF power (0 dB reference) ±1,0 dB
 - RF power relative to 0 dB reference (0 dBc to -45 dBc) ±1,0 dB

- RF power relative to 0 dB reference (< -45 dBc to -73 dBc) $\pm 1,5$ dB
- RF power (absolute limit values) $\pm 1,0$ dB

Clause 8.4, Adjacent channel power due to switching transients:

- Test case:
 - T1/T4 level $\pm 3,0$ dB

Maximum residual adjacent channel level of the test system:

- For a 25 kHz channel:
 - Maximum level at frequency offset 25 kHz -60 dBc
- For a 50 kHz channel:
 - Maximum level at frequency offset 37,5 kHz -60 dBc
- For a 100 kHz channel:
 - Maximum level at frequency offset 62,5 kHz -60 dBc
- For a 150 kHz channel:
 - Maximum level at frequency offset 87,5 kHz -60 dBc
- Test requirement:
 - RF power (0 dB reference) $\pm 1,0$ dB
 - RF power relative to 0 dB reference (0 dBc to -45 dBc) $\pm 1,0$ dB
 - RF power relative to 0 dB reference (< -45 dBc to -53 dBc) $\pm 1,5$ dB

Clause 8.5, Unwanted emissions far from the carrier; a) discrete spurious:

- Test case:
 - T1/T4 level $\pm 3,0$ dB
- Test requirement:
 - RF power (offsets within f_{rb}) $\pm 1,5$ dB
 - RF power (offsets > f_{rb} , not TETRA filtered):
 - $f \leq 1$ GHz $\pm 1,5$ dB
 - 1 GHz < $f \leq 2$ GHz $\pm 2,0$ dB
 - 2 GHz < $f \leq 4$ GHz $\pm 3,0$ dB
 - 4 GHz < $f \leq 12,75$ GHz $\pm 4,0$ dB

Clause 8.5, Unwanted emissions far from the carrier; b) wideband noise:

- Test case:
 - T1/T4 level $\pm 3,0$ dB
- Test requirement:
 - RF power relative to 0 dB reference (0 dBc to -45 dBc) $\pm 1,0$ dB
 - RF power relative to 0 dB reference (< -45 dBc to -105 dBc) $\pm 1,5$ dB

Clause 8.6, Unwanted radiated emissions:

- Test case:
 - T1/T4 level (conducted) ±3,0 dB
- Test requirement:
 - RF power (not TETRA filtered) ±4,0 dB

Clause 8.7, Unwanted emissions during the BLCH/CLCH (linearization):

- Test case:
 - T1/T4 level ±3,0 dB
- Test requirement:
 - RF power (0 dB reference) ±1,0 dB
 - RF power relative to 0 dB reference (0 dBc to -45 dBc) ±1,0 dB
 - RF power relative to 0 dB reference (< -45 dBc to -73 dBc) ±1,5 dB

Clause 8.8, Tx intermodulation attenuation:

- Test case:
 - T1/T4 level ±3,0 dB
 - T3 level (not TETRA filtered), relative to RF power ±1,0 dB
- Test requirement:
 - RF power (0 dB reference) ±1,0 dB
 - RF power (note) relative to 0 dB reference (0 dBc to -45 dBc) ±1,0 dB
 - RF power (note) relative to 0 dB ref. (< -45 dBc to -73 dBc) ±1,5 dB

NOTE: Not TETRA filtered.

11.2 Receiver

Where a measurement uncertainty of + x, x dB / 0,0 dB is specified for an input signal, the measured value of the input signal should be increased by an amount equal to the uncertainty with which it can be measured. This will ensure that the true value of the input signal is not below the specified nominal.

Clause 9.2, Nominal error rates:

- Test case:
 - T1/T4 level, static ±1,0 dB
 - T1/T4 level, dynamic ±1,5 dB

Clause 9.3, Reference sensitivity performance:

- Test case:
 - T1/T4 level, dynamic +3,0 dB / -0,0 dB

Clause 9.4, Reference interference performance:

- Test case:
 - T1/T4 level, dynamic +3,0 dB / -0,0 dB

- T2 level, static, relative to T1 or T4 ±1,0 dB
- T2 level, dynamic, relative to T1 or T4 ±1,5 dB

Clause 9.5, Blocking characteristics:

- Test case:
 - T1/T4 level, static +2,0 dB / -0,0 dB
 - T3 level (not TETRA filtered) ±1,0 dB
 - T3 noise level (not TETRA filtered):

The interferer shall be of adequate noise performance to enable the test to be performed so that its noise does not increase the noise level at the antenna connector by more than 1,0 dB at the received channel. This may require the use of additional filters to prevent an increase in the noise at the antenna connector.

Clause 9.6, Spurious response rejection:

- Test case:
 - T1/T4 level, static +2,0 dB / -0,0 dB
 - T3 level (not TETRA filtered):
 - $f \leq 1$ GHz ±1,0 dB
 - $1 \text{ GHz} < f \leq 2$ GHz ±1,5 dB
 - $f > 2$ GHz ±2,0 dB
 - T3 noise level (not TETRA filtered):

The interferer shall be of adequate noise performance to enable the test to be performed so that its noise does not increase the noise level at the antenna connector by more than 1,0 dB at the received channel. This may require the use of additional filters to prevent an increase in the noise at the antenna connector.

Clause 9.7, Intermodulation response rejection:

- Test case:
 - T1/T4 level, static +2,0 dB / -0,0 dB
 - T2 level, static ±1,0 dB
 - T3 level (not TETRA filtered) ±1,0 dB
 - T3 noise level (not TETRA filtered) and T2 noise level:

The interferers shall be of adequate noise performance to enable the test to be performed so that their noise does not increase the noise level at the antenna connector by more than 1,0 dB. This may require the use of additional filters to prevent an increase in the noise at the antenna connector.

Clause 9.8, Unwanted conducted emissions:

- Test requirement:
 - RF power (not TETRA filtered):
 - $f \leq 1$ GHz ±1,5 dB
 - $1 \text{ GHz} < f \leq 2$ GHz ±2,0 dB
 - $2 \text{ GHz} < f \leq 4$ GHz ±3,0 dB
 - $4 \text{ GHz} < f \leq 12,75$ GHz ±4,0 dB

Clause 9.9, Unwanted radiated emissions:

- Test case:
 - T1/T4 level (conducted) ±3,0 dB
- Test requirement:
 - RF power (not TETRA filtered) ±4,0 dB

11.3 Transmitter/receiver parameter definitions and limits

Clause 10.1, Modulation accuracy:

- Test case:
 - T1/T4 level ±3,0 dB
- Test requirement:
 - RMS vector error ±1,0 %
 - peak vector error ±3,0 %
 - Residual carrier magnitude ±1,0 %

Clause 10.2, Carrier frequency accuracy:

- Test case:
 - T1/T4 level ±3,0 dB
- Test requirement:
 - Frequency $137 \text{ MHz} \leq f \leq 520 \text{ MHz}$ ±0,02 ppm
 - Frequency $520 \text{ MHz} < f \leq 1 \text{ GHz}$ ±0,01 ppm

Clause 10.3, MS receiver performance for synchronization burst acquisition:

- Test case:
 - T1/T4 level, dynamic +3,0 dB / -0,0 dB

Clause 10.4, MS Frame alignment performance:

- Test case:
 - T1/T4 level, dynamic +3,0 dB / -0,0 dB
- Test requirement:
 - Timing uncertainty ±1/16 symbol

Clause 10.5, MS link control:

- Test case:
 - T1/T4 level, dynamic ±1,5 dB
- Test requirement:
 - RF power ±0,75 dB

11.4 Interpretation of measurement results

The measurement value related to the corresponding limit shall be used to decide whether equipment meets a requirement in the present document. The measurement uncertainty for the measurement of each parameter shall be included in the test report. The recorded value for the measurement uncertainty shall be, for each measurement, equal to or lower than the appropriate value in clause 11 of the present document.

NOTE: This procedure is recommended in ETSI ETR 028 [i.1].

Annex A (normative): TETRA receiver testing

A.1 Frequencies of spurious response

Annex A provides a definition of the interfering frequencies which are used during measurement of the spurious response rejection.

The interfering frequencies which are used during measurement of the spurious response rejection are defined as the combined frequencies of two sets of frequencies:

- a) All frequencies (f_l) in integer steps of the bandwidth of the signal divided by four and within the limited frequency range:

$$f_{lo} - \sum_{i=1}^n f_{ij} - \frac{sr}{2} \leq f_l \leq f_{lo} + \sum_{i=1}^n f_{ij} + \frac{sr}{2}$$

Where (sr) is the switching range of the receive band of the equipment, (f_{lo}) is the frequency of the local oscillator signal applied to the first mixer of the receiver and (f_{i1}, \dots, f_{in}) is the intermediate frequencies of the receiver.

- b) The discrete frequencies at which spurious response can occur outside the range determined in a) above for the remainder of the frequency range of interest up to 4 GHz determined as $nf_{lo} \pm f_{i1}$ and $pf_r \pm f_{i1}$, where n is an integer greater than or equal to 2, p is an integer greater than or equal to 1, (f_r) is the frequency of any other oscillator used to generate reference frequencies in the receiver and (f_{i1}) is the first intermediate frequencies of the receiver.

For the calculations a) and b) above, the manufacturer shall state the frequency of the receiver (f_0), the frequency of the local oscillator signal (f_{lo}) applied to the 1st mixer of the receiver, the frequency (f_r) of any other oscillator used to generate reference frequencies in the receiver, the intermediate frequencies (f_{i1}, \dots, f_{in}) and the switching range (sr) of the receiver (ETSI EN 300 392-2 [1]).

A.2 Test cases and test conditions for BS and MS receivers

Annex A contains receiver test tables A.1 to A.18 for TETRA BS and MS equipment for V+D applications. The tables list test type and provide information on channel type used in each test, test limits, minimum sample size and signal levels. Only in the case where a MS or BS supports protected circuit mode data shall the TCH/2,4 receiver sensitivity measurements be conducted. Test specifications and limits which are **bold** indicate a BER measurement and those which are not, are MER or FER measurements. For those tests measured under both normal and extreme test conditions, signal levels under extreme test conditions are shown in brackets, "()". Test tables for PUEM measurements are given at the end of the annex. The propagation models specified (TU50, HT200, EQ200) are defined in ETSI EN 300 392-2 [1], clause 6.8.3. The minimum sample size is determined from the following equation, from ETSI ETR 028 [i.1].

$$N = \frac{BER \times (1 - BER)}{\sigma_{BER}^2}$$

NOTE: The minimum number of samples refers to the number of bits for BER measurements and number of frames or messages for FER and MER measurements.

Table A.1: Test conditions for MS receiver V+D, class A, phase modulation

Test Type	Channel type	Logical channel	Propagation condition	Signal level (dBm)	Interferer level (dBm)	Spec. BER or MER %	Test limit BER or MER %	Minimum sample size
Nominal error	1	TCH/7,2	TU50	-85		0,4	0,448	3 600 000
Nominal error	1	TCH/7,2	STAT	-20		0,1	0,122	170 000
Sensitivity	2	SCH/F	TU50	-103 (-97)		8	8,96	6 600
Sensitivity	2	AACH	TU50	-103 (-97)		10	11,2	6 600
Sensitivity	3	BSCH	HT200	-103		11	12,32	4 800
Sensitivity	3	SCH/HD	HT200	-103		11	12,32	4 800
Sensitivity	4	AACH	HT200	-103		17	19,04	3 000
Sensitivity	4	TCH/2,4 N = 1	HT200	-103		1,1	1,232	1 290 000
Co-channel interference	2	SCH/F	HT200	-85	-104	9,2	10,304	7 000
Adjacent channel interference	2	SCH/F	TU50	-100 (-94)	-60 (-64)	6,5	7,280	8 000
Inter-modulation	1	TCH/7,2	STAT	-109	-47	3,5	4,270	5 000
Blocking	1	TCH/7,2	STAT	-109	-25	3,5	4,270	5 000
Spurious response	1	TCH/7,2	STAT	-109	-45	3,5	4,270	5 000
Nominal error	21	TCH-P8/10,8	STAT	-85		0,01	0,0122	1 499 775
Nominal error	21	TCH-P8/10,8	STAT	-20		0,1	0,122	149 774
Nominal error	21	TCH-P8/10,8	TU50	-85		0,4	0,448	125 364
Nominal error	21	TCH-P8/10,8	HT200	-85		5	5,6	9 444
Sensitivity	22	SCH-P8/HD	TU50	-97 (-91)		8,3 8,1 (see note)	9,3 9,3	5 474
Sensitivity	22	SCH-P8/HD	HT200	-97 (-91)		21 21 (see note)	23,52 23,52	1 764
Sensitivity	24	SCH-P8/F	TU50	-97 (-91)		10 10 (see note)	11,2 11,2	4 404
Sensitivity	24	SCH-P8/F	HT200	-97 (-91)		29 29 (see note)	32,48 32,48	1 102
Sensitivity	21	TCH-P8/10,8	TU50	-97 (-91)		1,6 1,6 (see note)	1,79 1,79	30 321
Sensitivity	21	TCH-P8/10,8	HT200	-97 (-91)		4,5 4,5 (see note)	5,04 5,04	10 564
Co-channel interference	22	SCH-P8/HD	TU50	-85	-110	7,6 7,9 (see note)	8,51 8,85	5 765
Co-channel interference	22	SCH-P8/HD	HT200	-85	-110	21 21 (see note)	23,52 23,52	1 764
Co-channel interference	24	SCH-P8/F	TU50	-85	-110	10 19 (see note)	11,2 21,28	2 017
Co-channel interference	24	SCH-P8/F	HT200	-85	-110	29 29 (see note)	32,48 32,48	1 102
Co-channel interference	21	TCH-P8/10,8	TU50	-85	-110	1,6 3,5 (see note)	1,79 3,92	13 764
Co-channel interference	21	TCH-P8/10,8	HT200	-85	-110	4,5 4,5 (see note)	5,04 5,04	10 564
Adjacent Channel Interference	22	SCH-P8/HD	TU50	-94 (-88)	-60 (-64)	7,6 7,9 (see note)	8,51 8,85	5 765
Adjacent Channel Interference	22	SCH-P8/HD	HT200	-94 (-88)	-60 (-64)	21 21 (see note)	23,52 23,52	1 764

Test Type	Channel type	Logical channel	Propagation condition	Signal level (dBm)	Interferer level (dBm)	Spec. BER or MER %	Test limit BER or MER %	Minimum sample size
Adjacent Channel Interference	24	SCH-P8/F	TU50	-94 (-88)	-60 (-64)	10 19 (see note)	11,2 21,28	2 017
Adjacent Channel Interference	24	SCH-P8/F	HT200	-94 (-88)	-60 (-64)	29 29 (see note)	32,48 32,48	1 102
Adjacent Channel Interference	21	TCH-P8/10,8	TU50	-94 (-88)	-60 (-64)	1,6 3,5 (see note)	1,79 3,92	13 764
Adjacent Channel Interference	21	TCH-P8/10,8	HT200	-94 (-88)	-60 (-64)	4,5 4,5 (see note)	5,04 5,04	10 564
Intermodulation response rejection	22	SCH-P8/HD	STAT	-104	-47	5,6	6,83	2 447
Intermodulation response rejection	24	SCH-P8/F	STAT	-104	-47	10	12,2	1 275
Intermodulation response rejection	21	TCH-P8/10,8	STAT	-104	-47	3,9	4,76	3 634
Blocking	22	SCH-P8/HD	STAT	-104	-25	5,6	6,83	2 447
Blocking	24	SCH-P8/F	STAT	-104	-25	10	12,2	1 275
Blocking	21	TCH-P8/10,8	STAT	-104	-25	3,9	4,76	3 634
Spurious response	22	SCH-P8/HD	STAT	-104	-45	5,6	6,83	2 447
Spurious response	24	SCH-P8/F	STAT	-104	-45	10	12,2	1 275
Spurious response	21	TCH-P8/10,8	STAT	-104	-45	3,9	4,76	3 634
NOTE: For Sensitivity, Co-channel and Adjacent channel interference tests, the two BER/MER numbers are for continuous/discontinuous downlink mode, respectively.								

Table A.2: Test conditions for MS receiver V+D, class B, phase modulation

Test Type	Channel Type	Logical channel	Propagation condition	Signal level (dBm)	Interferer level (dBm)	Spec. BER or MER %	Test limit BER or MER %	Minimum sample size
Nominal error	1	TCH/7,2	TU50	-85		0,4	0,448	3 600 000
Nominal error	1	TCH/7,2	STAT	-20		0,1	0,122	170 000
Sensitivity	2	SCH/F	TU50	-103 (-97)		8	8,96	6 600
Sensitivity	2	AACH	TU50	-103 (-97)		11	12,32	6 600
Sensitivity	3	BSCH	TU50	-103		8	8,96	6 600
Sensitivity	3	SCH/HD	TU50	-103		8	8,96	6 600
Sensitivity	4	AACH	TU50	-103		11	12,32	5 000
Sensitivity	4	TCH/2,4 N = 1	TU50	-103		0,35	0,392	2 160 000
Co-channel interference	2	SCH/F	TU50	-85	-104	6,5	7,280	8 500
Adjacent channel interference	2	SCH/F	TU50	-100 (-94)	-60 (-64)	6,5	7,280	8 000
Inter-modulation	1	TCH/7,2	STAT	-109	-47	4	4,880	4 500
Blocking	1	TCH/7,2	STAT	-109	-25	4	4,880	4 500
Spurious response	1	TCH/7,2	STAT	-109	-45	4	4,880	4 500
Nominal error	21	TCH-P8/10,8	STAT	-85		0,01	0,0122	1 499 775
Nominal error	21	TCH-P8/10,8	STAT	-20		0,1	0,122	149 774
Nominal error	21	TCH-P8/10,8	TU50	-85		0,4	0,448	125 364
Sensitivity	22	SCH-P8/HD	TU50	-97 (-91)		7,1	7,95	6 437
Sensitivity	24	SCH-P8/F	TU50	-97 (-91)		9,0	10,08	4 964
Sensitivity	21	TCH-P8/10,8	TU50	-97 (-91)		1,4	1,57	36 097
Co-channel interference	22	SCH-P8/HD	TU50	-85	-110	6,6	7,39	6 971
Co-channel interference	24	SCH-P8/F	TU50	-85	-110	8,9	9,97	5 044
Co-channel interference	21	TCH-P8/10,8	TU50	-85	-110	1,4	1,57	36 097
Adjacent Channel Interference	22	SCH-P8/HD	TU50	-94 (-88)	-60 (-64)	6,6	7,39	6 971
Adjacent Channel Interference	24	SCH-P8/F	TU50	-94 (-88)	-60 (-64)	8,9	9,97	5 044
Adjacent Channel Interference	21	TCH-P8/10,8	TU50	-94 (-88)	-60 (-64)	1,4	1,57	36 097
Intermodulation response rejection	22	SCH-P8/HD	STAT	-104	-47	1,6	1,95	9 068
Intermodulation response rejection	24	SCH-P8/F	STAT	-104	-47	9,3	11,35	1 392
Intermodulation response rejection	21	TCH-P8/10,8	STAT	-104	-47	3,2	3,90	4 422
Blocking	22	SCH-P8/HD	STAT	-104	-25	1,6	1,95	9 068
Blocking	24	SCH-P8/F	STAT	-104	-25	9,3	11,35	1 392
Blocking	21	TCH-P8/10,8	STAT	-104	-25	3,2	3,90	4 422
Spurious response	22	SCH-P8/HD	STAT	-104	-45	1,6	1,95	9 068
Spurious response	24	SCH-P8/F	STAT	-104	-45	9,3	11,35	1 392
Spurious response	21	TCH-P8/10,8	STAT	-104	-45	3,2	3,90	4 422

Table A.3: Test conditions for MS receiver V+D, class E, phase modulation

Test type	Channel type	Logical channel	Propagation condition	Signal level (dBm)	Interferer level (dBm)	Spec. BER or MER %	Test limit BER or MER %	Minimum sample size
Nominal error	1	TCH/7,2	TU50	-85		0,4	0,448	3 600 000
Nominal error	1	TCH/7,2	STAT	-20		0,1	0,122	170 000
Sensitivity	2	SCH/F	TU50	-103 (-97)		8	8,96	6 600
Sensitivity	2	AACH	TU50	-103 (-97)		10	11,2	6 600
Sensitivity	3	BSCH	EQ200	-103		22	24,64	2 000
Sensitivity	3	SCH/HD	EQ200	-103		21	23,52	2 000
Sensitivity	4	AACH	EQ200	-103		16	17,92	3 000
Sensitivity	4	TCH/2,4 N = 1	EQ200	-103		0,82	0,918	1 290 000
Co-channel interference	2	SCH/F	EQ200	-85	-104	20	22,4	3 500
Adjacent channel interference	2	SCH/F	TU50	-100 (-94)	-60 (-64)	6,5	7,28	8 000
Inter-modulation	1	TCH/7,2	STAT	-109	-47	3,5	4,27	4 500
Blocking	1	TCH/7,2	STAT	-109	-25	3,5	4,27	4 500
Spurious response	1	TCH/7,2	STAT	-109	-45	3,5	4,27	4 500

Table A.4: Test conditions for MS receiver V+D, class D, $\pi/8$ -D8PSK modulation

Test type	Channel type	Logical channel	Propagation condition	Signal level (dBm)	Interferer level (dBm)	Spec. BER or MER %	Test limit BER or MER %	Minimum sample size
Nominal error	21	TCH-P8/10,8	STAT	-85		0,01	0,0122	1 499 775
Nominal error	21	TCH-P8/10,8	STAT	-20		0,1	0,122	149 774
Nominal error	21	TCH-P8/10,8	TU50	-85		0,4	0,448	125 364
Nominal error	21	TCH-P8/10,8	HT200	-85		5	5,6	9 444
Sensitivity	22	SCH-P8/HD	TU50	-97 (-91)		8,3 8,1 (see note)	9,3 9,3	5 474
Sensitivity	22	SCH-P8/HD	HT200	-97 (-91)		15 15 (see note)	16,8 16,8	2 724
Sensitivity	24	SCH-P8/F	TU50	-97 (-91)		10 10 (see note)	11,2 11,2	4 404
Sensitivity	24	SCH-P8/F	HT200	-97 (-91)		18 18 (see note)	20,16 20,16	2 164
Sensitivity	21	TCH-P8/10,8	TU50	-97 (-91)		1,6 1,6 (see note)	1,79 1,79	30 321
Sensitivity	21	TCH-P8/10,8	HT200	-97 (-91)		3,4 3,6 (see note)	3,81 4,032	13 364
Co-channel interference	22	SCH-P8/HD	TU50	-85	-110	7,6 7,9 (see note)	8,51 8,85	5 765
Co-channel interference	22	SCH-P8/HD	HT200	-85	-110	16 15 (see note)	17,92 16,8	2 514
Co-channel interference	24	SCH-P8/F	TU50	-85	-110	10 19 (see note)	11,2 21,28	2 017
Co-channel interference	24	SCH-P8/F	HT200	-85	-110	19 18 (see note)	21,28 20,16	2 017

Test type	Channel type	Logical channel	Propagation condition	Signal level (dBm)	Interferer level (dBm)	Spec. BER or MER %	Test limit BER or MER %	Minimum sample size
Co-channel interference	21	TCH-P8/10,8	TU50	-85	-110	1,6 3,5 (see note)	1,79 3,92	13 764
Co-channel interference	21	TCH-P8/10,8	HT200	-85	-110	3,5 3,6 (see note)	3,92 4,032	13 364
Adjacent Channel Interference	22	SCH-P8/HD	TU50	-94 (-88)	-60 (-64)	7,6 7,9 (see note)	8,51 8,85	5 765
Adjacent Channel Interference	22	SCH-P8/HD	HT200	-94 (-88)	-60 (-64)	16 15 (see note)	17,92 16,8	2 514
Adjacent Channel Interference	24	SCH-P8/F	TU50	-94 (-88)	-60 (-64)	10 19 (see note)	11,2 21,28	2 017
Adjacent Channel Interference	24	SCH-P8/F	HT200	-94 (-88)	-60 (-64)	19 18 (see note)	21,28 20,16	2 017
Adjacent Channel Interference	21	TCH-P8/10,8	TU50	-94 (-88)	-60 (-64)	1,6 3,5 (see note)	1,79 3,92	13 764
Adjacent Channel Interference	21	TCH-P8/10,8	HT200	-94 (-88)	-60 (-64)	3,5 3,6 (see note)	3,92 4,032	13 364
Intermodulation response rejection	22	SCH-P8/HD	STAT	-104	-47	5,6	6,83	2 447
Intermodulation response rejection	24	SCH-P8/F	STAT	-104	-47	10	12,2	1 275
Intermodulation response rejection	21	TCH-P8/10,8	STAT	-104	-47	3,9	4,76	3 634
Blocking	22	SCH-P8/HD	STAT	-104	-25	5,6	6,83	2 447
Blocking	24	SCH-P8/F	STAT	-104	-25	10	12,2	1 275
Blocking	21	TCH-P8/10,8	STAT	-104	-25	3,9	4,76	3 634
Spurious response	22	SCH-P8/HD	STAT	-104	-45	5,6	6,83	2 447
Spurious response	24	SCH-P8/F	STAT	-104	-45	10	12,2	1 275
Spurious response	21	TCH-P8/10,8	STAT	-104	-45	3,9	4,76	3 634

NOTE: For Sensitivity, Co-channel and Adjacent channel interference tests, the two BER/MER numbers are for continuous/discontinuous downlink mode, respectively.

Table A.5: Test conditions for BS receiver V+D, class A, phase modulation

Test type	Channel type	Logical channel	Propagation condition	Signal level (dBm)	Interferer level (dBm)	Spec. BER or MER %	Test limit BER or MER %	Minimum sample size
Nominal error	7	TCH/7,2	TU50	-85		0,4	0,448	3 600 000
Nominal error	7	TCH/7,2	STAT	-20		0,1	0,122	170 000
Sensitivity	8	SCH/F	TU50	-106 (-100)		11	12,32	6 600
Sensitivity	9	STCH	TU50	-106		9	10,08	6 600
Sensitivity	10	TCH/2,4 N = 1	HT200	-106		1,3	1,456	45 000
Sensitivity	11	SCH/HU	HT200	-106		9,5	10,64	5 000
Co-channel interference	8	SCH/F	HT200	-85	-104	9,2	10,30	7 000
Adjacent channel interference	8	SCH/F	TU50	-103 (-97)	-58 (-62) (see note)	6	6,72	9 000
Inter-modulation	7	TCH/7,2	STAT	-112	-47	3,0	3,66	5 800

Test type	Channel type	Logical channel	Propagation condition	Signal level (dBm)	Interferer level (dBm)	Spec. BER or MER %	Test limit BER or MER %	Minimum sample size
Blocking	7	TCH/7,2	STAT	-112	-25	3,0	3,66	5 800
Spurious response	7	TCH/7,2	STAT	-112	-45	3,0	3,66	5 800
Nominal error	21	TCH-P8/10,8	STAT	-85		0,01	0,0122	1 499 775
Nominal error	21	TCH-P8/10,8	STAT	-20		0,1	0,122	149 774
Nominal error	21	TCH-P8/10,8	TU50	-85		0,4	0,448	125 364
Nominal error	21	TCH-P8/10,8	HT200	-85		5	5,6	9 444
Sensitivity	23	SCH-P8/HU	TU50	-100 (-94)		7,4	8,29	6 199
Sensitivity	23	SCH-P8/HU	HT200	-100 (-94)		19	21,28	2 017
Sensitivity	24	SCH-P8/F	TU50	-100 (-94)		10	11,2	4 404
Sensitivity	24	SCH-P8/F	HT200	-100 (-94)		29	32,48	1 102
Sensitivity	21	TCH-P8/10,8	TU50	-100 (-94)		1,6	1,79	30 321
Sensitivity	21	TCH-P8/10,8	HT200	-100 (-94)		4,5	5,04	10 564
Co-channel interference	23	SCH-P8/HU	TU50	-85	-110	7,3	8,18	6 318
Co-channel interference	23	SCH-P8/HU	HT200	-85	-110	19	21,28	2 017
Co-channel interference	24	SCH-P8/F	TU50	-85	-110	10	11,2	4 404
Co-channel interference	24	SCH-P8/F	HT200	-85	-110	29	21,28	78
Co-channel interference	21	TCH-P8/10,8	TU50	-85	-110	1,6	1,79	30 321
Co-channel interference	21	TCH-P8/10,8	HT200	-85	-110	4,5	5,04	10 564
Adjacent channel interference	23	SCH-P8/HU	TU50	-97 (-91)	-58 (-62) (see note)	7,3	8,18	6 318
Adjacent channel interference	23	SCH-P8/HU	HT200	-97 (-91)	-58 (-62) (see note)	19	21,28	2 017
Adjacent channel interference	24	SCH-P8/F	TU50	-97 (-91)	-58 (-62) (see note)	10	11,2	4 404
Adjacent channel interference	24	SCH-P8/F	HT200	-97 (-91)	-58 (-62) (see note)	29	21,28	78
Adjacent channel interference	21	TCH-P8/10,8	TU50	-97 (-91)	-58 (-62) (see note)	1,6	1,79	30 321
Adjacent channel interference	21	TCH-P8/10,8	HT200	-97 (-91)	-58 (-62) (see note)	4,5	5,04	10 564
Inter-modulation	23	SCH-P8/HU	STAT	-107	-47	4,5	5,49	3 108
Inter-modulation	24	SCH-P8/F	STAT	-107	-47	9,3	11,35	1 392
Inter-modulation	21	TCH-P8/10,8	STAT	-107	-47	3,8	4,64	3 750
Blocking	23	SCH-P8/HU	STAT	-107	-25	4,5	5,49	3 108
Blocking	24	SCH-P8/F	STAT	-107	-25	9,3	11,35	1 392
Blocking	21	TCH-P8/10,8	STAT	-107	-25	3,8	4,64	3 750
Spurious	23	SCH-P8/HU	STAT	-107	-45	4,5	5,49	3 108
Spurious	24	SCH-P8/F	STAT	-107	-45	9,3	11,35	1 392
Spurious	21	TCH-P8/10,8	STAT	-107	-45	3,8	4,64	3 750

NOTE: For frequencies above 700 MHz, the levels are -63 (-67).

Table A.6: Test conditions for BS receiver V+D, class B, phase modulation

Test type	Channel type	Logical channel	Propagation condition	Signal level (dBm)	Interferer level (dBm)	Spec. BER or MER %	Test limit BER or MER %	Minimum sample size
Nominal error	7	TCH/7,2	TU50	-85		0,4	0,448	3 600 000
Nominal error	7	TCH/7,2	STAT	-20		0,1	0,122	170 000
Sensitivity	8	SCH/F	TU50	-106 (-100)		8	8,96	6 600
Sensitivity	9	STCH	TU50	-106		8	8,96	6 600
Sensitivity	10	TCH/2,4 N = 1	TU50	-106		0,35	0,392	160 000
Sensitivity	11	SCH/HU	TU50	-106		8	8,96	6 600
Co-channel interference	8	SCH/F	TU50	-85	-104	6	6,72	7 000
Adjacent channel interference	8	SCH/F	TU50	-103 (-97)	-58 (-62) (see note)	6	6,72	9 000
Inter-modulation	7	TCH/7,2	STAT	-112	-47	4,0	4,88	4 000
Blocking	7	TCH/7,2	STAT	-112	-25	4,0	4,88	4 000
Spurious response	7	TCH/7,2	STAT	-112	-45	4,0	4,88	4 000
Nominal error	21	TCH-P8/10,8	STAT	-85		0,01	0,0122	1 499 775
Nominal error	21	TCH-P8/10,8	STAT	-20		0,1	0,122	149 774
Nominal error	21	TCH-P8/10,8	TU50	-85		0,4	0,448	125 364
Sensitivity	23	SCH-P8/HU	TU50	-100 (-94)		6,3	7,06	7 432
Sensitivity	24	SCH-P8/F	TU50	-100 (-94)		8,9	9,97	5 044
Sensitivity	21	TCH-P8/10,8	TU50	-100 (-94)		1,4	1,57	36 097
Co-channel interference	23	SCH-P8/HU	TU50	-85	-110	6,6	7,39	6 971
Co-channel interference	24	SCH-P8/F	TU50	-85	-110	9,1	10,19	4 888
Co-channel interference	21	TCH-P8/10,8	TU50	-85	-110	1,4	1,57	36 097
Adjacent channel interference	23	SCH-P8/HU	TU50	-97 (-91)	-58 (-62) (see note)	6,6	7,39	6 971
Adjacent channel interference	24	SCH-P8/F	TU50	-97 (-91)	-58 (-62) (see note)	9,1	10,19	4 888
Adjacent channel interference	21	TCH-P8/10,8	TU50	-97 (-91)	-58 (-62) (see note)	1,4	1,57	36 097
Inter-modulation	23	SCH-P8/HU	STAT	-107	-47	4,3	5,25	3 285
Inter-modulation	24	SCH-P8/F	STAT	-107	-47	9,3	11,35	1 392
Inter-modulation	21	TCH-P8/10,8	STAT	-107	-47	3,1	3,78	4 592
Blocking	23	SCH-P8/HU	STAT	-107	-25	4,3	5,25	3 285
Blocking	24	SCH-P8/F	STAT	-107	-25	9,3	11,35	1 392
Blocking	21	TCH-P8/10,8	STAT	-107	-25	3,1	3,78	4 592
Spurious	23	SCH-P8/HU	STAT	-107	-45	4,3	5,25	3 285
Spurious	24	SCH-P8/F	STAT	-107	-45	9,3	11,35	1 392
Spurious	21	TCH-P8/10,8	STAT	-107	-45	3,1	3,78	4 592

NOTE: For frequencies above 700 MHz, the levels are -63 (-67).

Table A.7: Test conditions for BS receiver V+D, class D, $\pi/8$ -D8PSK modulation

Test type	Channel type	Logical channel	Propagation condition	Signal level (dBm)	Interferer level (dBm)	Spec. BER or MER %	Test limit BER or MER %	Minimum sample size
Nominal error	7	TCH/7,2	TU50	-85		0,4	0,448	3 600 000
Nominal error	7	TCH/7,2	STAT	-20		0,1	0,122	170 000
Sensitivity	8	SCH/F	TU50	-106 (-100)		11	12,32	6 600
Sensitivity	9	STCH	TU50	-106		9	10,08	6 600
Sensitivity	10	TCH/2,4 N = 1	HT200	-106		1,3	1,456	45 000
Sensitivity	11	SCH/HU	HT200	-106		9,5	10,64	5 000
Co-channel interference	8	SCH/F	HT200	-85	-104	9,2	10,304	7 000
Adjacent channel interference	8	SCH/F	TU50	-103 (-97)	-58 (-62) (see note)	6	6,72	9 000
Inter-modulation	7	TCH/7,2	STAT	-112	-47	3,0	3,66	5 800
Blocking	7	TCH/7,2	STAT	-112	-25	3,0	3,66	5 800
Spurious response	7	TCH/7,2	STAT	-112	-45	3,0	3,66	5 800
Nominal error	21	TCH-P8/10,8	STAT	-85		0,01	0,0122	1 499 775
Nominal error	21	TCH-P8/10,8	STAT	-20		0,1	0,122	149 774
Nominal error	21	TCH-P8/10,8	TU50	-85		0,4	0,448	125 364
Nominal error	21	TCH-P8/10,8	HT200	-85		5	5,6	9 444
Sensitivity	23	SCH-P8/HU	TU50	-100 (-94)		7,4	8,29	6 199
Sensitivity	23	SCH-P8/HU	HT200	-100 (-94)		14	15,68	2 964
Sensitivity	24	SCH-P8/F	TU50	-100 (-94)		10	11,2	4 404
Sensitivity	24	SCH-P8/F	HT200	-100 (-94)		18	20,16	2 164
Sensitivity	21	TCH-P8/10,8	TU50	-100 (-94)		1,6	1,79	30 321
Sensitivity	21	TCH-P8/10,8	HT200	-100 (-94)		3,6	4,03	13 259
Co-channel interference	23	SCH-P8/HU	TU50	-85	-110	7,3	8,18	6 318
Co-channel interference	23	SCH-P8/HU	HT200	-85	-110	13	14,56	3 241
Co-channel interference	24	SCH-P8/F	TU50	-85	-110	10	11,2	4 404
Co-channel interference	24	SCH-P8/F	HT200	-85	-110	18	20,16	2 164
Co-channel interference	21	TCH-P8/10,8	TU50	-85	-110	1,6	1,79	30 321
Co-channel interference	21	TCH-P8/10,8	HT200	-85	-110	3,7	4,14	12 788
Adjacent channel interference	23	SCH-P8/HU	TU50	-97 (-91)	-58 (-62) (see note)	7,3	8,18	6 318
Adjacent channel interference	23	SCH-P8/HU	HT200	-97 (-91)	-58 (-62) (see note)	13	14,56	3 241
Adjacent channel interference	24	SCH-P8/F	TU50	-97 (-91)	-58 (-62) (see note)	10	11,2	4 404
Adjacent channel interference	24	SCH-P8/F	HT200	-97 (-91)	-58 (-62) (see note)	18	20,16	2 164
Adjacent channel interference	21	TCH-P8/10,8	TU50	-97 (-91)	-58 (-62) (see note)	1,6	1,79	30 321
Adjacent channel interference	21	TCH-P8/10,8	HT200	-97 (-91)	-58 (-62) (see note)	3,7	4,14	12 788
Inter-modulation	23	SCH-P8/HU	STAT	-107	-47	4,5	5,49	3 108
Inter-modulation	24	SCH-P8/F	STAT	-107	-47	9,3	11,35	1 392
Inter-modulation	21	TCH-P8/10,8	STAT	-107	-47	3,8	4,64	3 750

Test type	Channel type	Logical channel	Propagation condition	Signal level (dBm)	Interferer level (dBm)	Spec. BER or MER %	Test limit BER or MER %	Minimum sample size
Blocking	23	SCH-P8/HU	STAT	-107	-25	4,5	5,49	3 108
Blocking	24	SCH-P8/F	STAT	-107	-25	9,3	11,35	1 392
Blocking	21	TCH-P8/10,8	STAT	-107	-25	3,8	4,64	3 750
Spurious	23	SCH-P8/HU	STAT	-107	-45	4,5	5,49	3 108
Spurious	24	SCH-P8/F	STAT	-107	-45	9,3	11,35	1 392
Spurious	21	TCH-P8/10,8	STAT	-107	-45	3,8	4,64	3 750

NOTE: For frequencies above 700 MHz, the levels are -63 (-67).

Table A.8: PUEM test table, phase modulation

Equipment type	Channel type	Logical channel	Propagation condition	Signal level (dBm)	Spec. PUEM	Bad unit (PUEM)	Test limit (Max No. Errors)	Sample size
MS	2	SCH/F AACH	TU50	-103	10^{-5} 10^{-4}	$3,5 \times 10^{-4}$ $6,5 \times 10^{-4}$	2 8	31 200
MS	22	SCH-P8/HD	TU50	-97	10^{-5}	$3,5 \times 10^{-4}$	2	31 200
MS	24	SCH-P8/F	TU50	-97	10^{-5}	$3,5 \times 10^{-4}$	2	31 200
BS	8	SCH/F	TU50	-106	10^{-5}	$3,5 \times 10^{-4}$	2	31 200
BS	23	SCH-P8/HU	TU50	-100	10^{-5}	$3,5 \times 10^{-4}$	2	31 200

Table A.9: Test Conditions for BS receiver V+D, QAM modulation

Test type	Channel type	Logical channel	Payload code rate	Payload modulation	BW (kHz)	Propagation condition	Signal level (dBm)	Interferer level (dBm)	Spec. BER or MER %	Test limit BER or MER %	Minimum sample size
Nominal error	26	SCH-Q/U	1/2	4-QAM	25	Static	-20		10	11,2	4 000
Nominal error	26	SCH-Q/U	1/2	4-QAM	50	Static	-20		10	11,2	4 000
Nominal error	26	SCH-Q/U	1/2	4-QAM	100	Static	-20		10	11,2	4 000
Nominal error	26	SCH-Q/U	1/2	4-QAM	150	Static	-20		10	11,2	4 000
Nominal error	26	SCH-Q/U	1/2	16-QAM	25	Static	-20		10	11,2	4 000
Nominal error	26	SCH-Q/U	1/2	16-QAM	50	Static	-20		10	11,2	4 000
Nominal error	26	SCH-Q/U	1/2	16-QAM	100	Static	-20		10	11,2	4 000
Nominal error	26	SCH-Q/U	1/2	16-QAM	150	Static	-20		10	11,2	4 000
Sensitivity	26	SCH-Q/U	1	4-QAM	25	Static	-116		3	3,66	4 775
Sensitivity	26	SCH-Q/U	1	4-QAM	50	Static	-113		3	3,66	4 775
Sensitivity	26	SCH-Q/U	1	4-QAM	100	Static	-110		3	3,66	4 775
Sensitivity	26	SCH-Q/U	1	4-QAM	150	Static	-108		3	3,66	4 775
Sensitivity	26	SCH-Q/U	1	16-QAM	25	Static	-109		3	3,66	4 775
Sensitivity	26	SCH-Q/U	1	16-QAM	50	Static	-106		3	3,66	4 775
Sensitivity	26	SCH-Q/U	1	16-QAM	100	Static	-103		3	3,66	4 775
Sensitivity	26	SCH-Q/U	1	16-QAM	150	Static	-102		3	3,66	4 775
Sensitivity	26	SCH-Q/U	1	64-QAM	25	Static	-104		3	3,66	4 775
Sensitivity	26	SCH-Q/U	1	64-QAM	50	Static	-100		3	3,66	4 775
Sensitivity	26	SCH-Q/U	1	64-QAM	100	Static	-98		3	3,66	4 775
Sensitivity	26	SCH-Q/U	1	64-QAM	150	Static	-96		3	3,66	4 775
Adjacent channel interference	26	SCH-Q/U	1	4-QAM	25	Static	-113	-62	3	3,66	4 775
Adjacent channel interference	26	SCH-Q/U	1	4-QAM	50	Static	-110	-65	3	3,66	4 775

Test type	Channel type	Logical channel	Payload code rate	Payload modulation	BW (kHz)	Propagation condition	Signal level (dBm)	Interferer level (dBm)	Spec. BER or MER %	Test limit BER or MER %	Minimum sample size
Adjacent channel interference	26	SCH-Q/U	1	4-QAM	100	Static	-107	-65	3	3,66	4 775
Adjacent channel interference	26	SCH-Q/U	1	4-QAM	150	Static	-105	-65	3	3,66	4 775
Adjacent channel interference	26	SCH-Q/U	1	16-QAM	25	Static	-106 (-100)	-62 (-66)	3	3,66	4 775
Adjacent channel interference	26	SCH-Q/U	1	16-QAM	50	Static	-103 (-97)	-65 (-69)	3	3,66	4 775
Adjacent channel interference	26	SCH-Q/U	1	16-QAM	100	Static	-100 (-94)	-65 (-69)	3	3,66	4 775
Adjacent channel interference	26	SCH-Q/U	1	16-QAM	150	Static	-99 (-93)	-65 (-69)	3	3,66	4 775
Adjacent channel interference	26	SCH-Q/U	1	64-QAM	25	Static	-101	-62	3	3,66	4 775
Adjacent channel interference	26	SCH-Q/U	1	64-QAM	50	Static	-97	-65	3	3,66	4 775
Adjacent channel interference	26	SCH-Q/U	1	64-QAM	100	Static	-95	-65	3	3,66	4 775
Adjacent channel interference	26	SCH-Q/U	1	64-QAM	150	Static	-93	-65	3	3,66	4 775
Blocking	26	SCH-Q/U	1	4-QAM	25	Static	-113	-40	3	3,66	4 775
Blocking	26	SCH-Q/U	1	4-QAM	25	Static	-113	-35	3	3,66	4 775
Blocking	26	SCH-Q/U	1	4-QAM	25	Static	-113	-30	3	3,66	4 775
Blocking	26	SCH-Q/U	1	4-QAM	25	Static	-113	-25	3	3,66	4 775
Blocking	26	SCH-Q/U	1	4-QAM	50	Static	-110	-40	3	3,66	4 775
Blocking	26	SCH-Q/U	1	4-QAM	50	Static	-110	-35	3	3,66	4 775
Blocking	26	SCH-Q/U	1	4-QAM	50	Static	-110	-30	3	3,66	4 775
Blocking	26	SCH-Q/U	1	4-QAM	50	Static	-110	-25	3	3,66	4 775
Blocking	26	SCH-Q/U	1	4-QAM	100	Static	-107	-40	3	3,66	4 775
Blocking	26	SCH-Q/U	1	4-QAM	100	Static	-107	-35	3	3,66	4 775
Blocking	26	SCH-Q/U	1	4-QAM	100	Static	-107	-30	3	3,66	4 775
Blocking	26	SCH-Q/U	1	4-QAM	100	Static	-107	-25	3	3,66	4 775
Blocking	26	SCH-Q/U	1	4-QAM	150	Static	-105	-40	3	3,66	4 775
Blocking	26	SCH-Q/U	1	4-QAM	150	Static	-105	-35	3	3,66	4 775
Blocking	26	SCH-Q/U	1	4-QAM	150	Static	-105	-30	3	3,66	4 775
Blocking	26	SCH-Q/U	1	4-QAM	150	Static	-105	-25	3	3,66	4 775
Blocking	26	SCH-Q/U	1	16-QAM	25	Static	-106	-40	3	3,66	4 775
Blocking	26	SCH-Q/U	1	16-QAM	25	Static	-106	-35	3	3,66	4 775
Blocking	26	SCH-Q/U	1	16-QAM	25	Static	-106	-30	3	3,66	4 775
Blocking	26	SCH-Q/U	1	16-QAM	25	Static	-106	-25	3	3,66	4 775
Blocking	26	SCH-Q/U	1	16-QAM	50	Static	-103	-40	3	3,66	4 775
Blocking	26	SCH-Q/U	1	16-QAM	50	Static	-103	-35	3	3,66	4 775
Blocking	26	SCH-Q/U	1	16-QAM	50	Static	-103	-30	3	3,66	4 775
Blocking	26	SCH-Q/U	1	16-QAM	50	Static	-103	-25	3	3,66	4 775
Blocking	26	SCH-Q/U	1	16-QAM	100	Static	-100	-40	3	3,66	4 775
Blocking	26	SCH-Q/U	1	16-QAM	100	Static	-100	-35	3	3,66	4 775
Blocking	26	SCH-Q/U	1	16-QAM	100	Static	-100	-30	3	3,66	4 775
Blocking	26	SCH-Q/U	1	16-QAM	100	Static	-100	-25	3	3,66	4 775
Blocking	26	SCH-Q/U	1	16-QAM	150	Static	-99	-40	3	3,66	4 775
Blocking	26	SCH-Q/U	1	16-QAM	150	Static	-99	-35	3	3,66	4 775
Blocking	26	SCH-Q/U	1	16-QAM	150	Static	-99	-30	3	3,66	4 775
Blocking	26	SCH-Q/U	1	16-QAM	150	Static	-99	-25	3	3,66	4 775
Blocking	26	SCH-Q/U	1	64-QAM	25	Static	-101	-40	3	3,66	4 775

Test type	Channel type	Logical channel	Payload code rate	Payload modulation	BW (kHz)	Propagation condition	Signal level (dBm)	Interferer level (dBm)	Spec. BER or MER %	Test limit BER or MER %	Minimum sample size
Blocking	26	SCH-Q/U	1	64-QAM	25	Static	-101	-35	3	3,66	4 775
Blocking	26	SCH-Q/U	1	64-QAM	25	Static	-101	-30	3	3,66	4 775
Blocking	26	SCH-Q/U	1	64-QAM	25	Static	-101	-25	3	3,66	4 775
Blocking	26	SCH-Q/U	1	64-QAM	50	Static	-97	-40	3	3,66	4 775
Blocking	26	SCH-Q/U	1	64-QAM	50	Static	-97	-35	3	3,66	4 775
Blocking	26	SCH-Q/U	1	64-QAM	50	Static	-97	-30	3	3,66	4 775
Blocking	26	SCH-Q/U	1	64-QAM	50	Static	-97	-25	3	3,66	4 775
Blocking	26	SCH-Q/U	1	64-QAM	100	Static	-95	-40	3	3,66	4 775
Blocking	26	SCH-Q/U	1	64-QAM	100	Static	-95	-35	3	3,66	4 775
Blocking	26	SCH-Q/U	1	64-QAM	100	Static	-95	-30	3	3,66	4 775
Blocking	26	SCH-Q/U	1	64-QAM	100	Static	-95	-25	3	3,66	4 775
Blocking	26	SCH-Q/U	1	64-QAM	150	Static	-93	-40	3	3,66	4 775
Blocking	26	SCH-Q/U	1	64-QAM	150	Static	-93	-35	3	3,66	4 775
Blocking	26	SCH-Q/U	1	64-QAM	150	Static	-93	-30	3	3,66	4 775
Blocking	26	SCH-Q/U	1	64-QAM	150	Static	-93	-25	3	3,66	4 775
Spurious response	26	SCH-Q/U	1	4-QAM	25	Static	-113	-45	3	3,66	4 775
Spurious response	26	SCH-Q/U	1	4-QAM	50	Static	-110	-45	3	3,66	4 775
Spurious response	26	SCH-Q/U	1	4-QAM	100	Static	-107	-45	3	3,66	4 775
Spurious response	26	SCH-Q/U	1	4-QAM	150	Static	-105	-45	3	3,66	4 775
Spurious response	26	SCH-Q/U	1	16-QAM	25	Static	-106	-45	3	3,66	4 775
Spurious response	26	SCH-Q/U	1	16-QAM	50	Static	-103	-45	3	3,66	4 775
Spurious response	26	SCH-Q/U	1	16-QAM	100	Static	-100	-45	3	3,66	4 775
Spurious response	26	SCH-Q/U	1	16-QAM	150	Static	-99	-45	3	3,66	4 775
Spurious response	26	SCH-Q/U	1	64-QAM	25	Static	-101	-45	3	3,66	4 775
Spurious response	26	SCH-Q/U	1	64-QAM	50	Static	-97	-45	3	3,66	4 775
Spurious response	26	SCH-Q/U	1	64-QAM	100	Static	-95	-45	3	3,66	4 775
Spurious response	26	SCH-Q/U	1	64-QAM	150	Static	-93	-45	3	3,66	4 775
Inter-modulation	26	SCH-Q/U	1	4-QAM	25	Static	-113	-47	3	3,66	4 775
Inter-modulation	26	SCH-Q/U	1	4-QAM	50	Static	-110	-47	3	3,66	4 775
Inter-modulation	26	SCH-Q/U	1	4-QAM	100	Static	-107	-47	3	3,66	4 775
Inter-modulation	26	SCH-Q/U	1	4-QAM	150	Static	-105	-47	3	3,66	4 775
Inter-modulation	26	SCH-Q/U	1	16-QAM	25	Static	-106	-47	3	3,66	4 775
Inter-modulation	26	SCH-Q/U	1	16-QAM	50	Static	-103	-47	3	3,66	4 775
Inter-modulation	26	SCH-Q/U	1	16-QAM	100	Static	-100	-47	3	3,66	4 775
Inter-modulation	26	SCH-Q/U	1	16-QAM	150	Static	-99	-47	3	3,66	4 775
Inter-modulation	26	SCH-Q/U	1	64-QAM	25	Static	-101	-47	3	3,66	4 775
Inter-modulation	26	SCH-Q/U	1	64-QAM	50	Static	-97	-47	3	3,66	4 775
Inter-modulation	26	SCH-Q/U	1	64-QAM	100	Static	-95	-47	3	3,66	4 775
Inter-modulation	26	SCH-Q/U	1	64-QAM	150	Static	-93	-47	3	3,66	4 775

Table A.10: Test Conditions for BS receiver V+D, QAM modulation, and frequencies above 700 MHz

Test type	Channel type	Logical channel	Payload code rate	Payload modulation	BW (kHz)	Propagation condition	Signal level (dBm)	Interferer level (dBm)	Spec. MER %	Test limit MER %	Minimum sample size
Sensitivity	25	SICH-Q/U	1/2	4-QAM	25	TU50	-111		4,60	5,15	10 257
Sensitivity	25	SICH-Q/U	1/2	4-QAM	25	HT200	-111		1,00	1,12	49 764
Sensitivity	25	SICH-Q/U	1/2	4-QAM	50	TU50	-108		5,30	5,94	8 970
Sensitivity	25	SICH-Q/U	1/2	4-QAM	50	HT200	-108		1,10	1,23	44 032
Sensitivity	25	SICH-Q/U	1/2	4-QAM	100	TU50	-105		3,00	3,36	16 164
Sensitivity	25	SICH-Q/U	1/2	4-QAM	100	HT200	-105		1,20	1,34	39 463
Sensitivity	25	SICH-Q/U	1/2	4-QAM	150	TU50	-104		4,20	4,7	11 211
Sensitivity	25	SICH-Q/U	1/2	4-QAM	150	HT200	-104		1,40	1,57	36 097
Sensitivity	26	SICH-Q/U	1/2	4-QAM	25	TU50	-111		2,60	2,91	18 545
Sensitivity	26	SICH-Q/U	1/2	4-QAM	25	HT200	-111		1,00	1,12	49 764
Sensitivity	26	SICH-Q/U	1/2	4-QAM	50	TU50	-108		3,20	3,58	14 848
Sensitivity	26	SICH-Q/U	1/2	4-QAM	50	HT200	-108		0,90	1,01	57 165
Sensitivity	26	SICH-Q/U	1/2	4-QAM	100	TU50	-105		1,20	1,34	39 463
Sensitivity	26	SICH-Q/U	1/2	4-QAM	100	HT200	-105		1,00	1,12	49 764
Sensitivity	26	SICH-Q/U	1/2	4-QAM	150	TU50	-104		3,70	4,14	12 788
Sensitivity	26	SICH-Q/U	1/2	4-QAM	150	HT200	-104		1,40	1,57	36 097
Sensitivity	28	SCH-Q/RA	1/2	4-QAM	25	TU50	-111		14,20	15,9	2 902
Sensitivity	28	SCH-Q/RA	1/2	4-QAM	25	HT200	-111		5,90	6,61	7 945
Sensitivity	25	SCH-Q/HU	1/2	4-QAM	25	TU50	-111		14,30	16,02	2 901
Sensitivity	25	SCH-Q/HU	1/2	4-QAM	25	HT200	-111		5,50	6,16	8 528
Sensitivity	25	SCH-Q/HU	1/2	4-QAM	50	TU50	-108		14,20	15,9	2 902
Sensitivity	25	SCH-Q/HU	1/2	4-QAM	50	HT200	-108		4,40	4,93	10 890
Sensitivity	25	SCH-Q/HU	1/2	4-QAM	100	TU50	-105		10,30	11,54	4 281
Sensitivity	25	SCH-Q/HU	1/2	4-QAM	100	HT200	-105		3,50	3,92	13 764
Sensitivity	25	SCH-Q/HU	1/2	4-QAM	150	TU50	-104		13,40	15,01	3 132
Sensitivity	25	SCH-Q/HU	1/2	4-QAM	150	HT200	-104		5,20	5,82	8 958
Sensitivity	25	SCH-Q/HU	1/2	16-QAM	25	TU50	-107 (-101)		16,50	18,48	2 419
Sensitivity	25	SCH-Q/HU	1/2	16-QAM	25	HT200	-107		10,80	12,1	4 053
Sensitivity	25	SCH-Q/HU	1/2	16-QAM	50	TU50	-103 (-97)		14,20	15,9	2 902
Sensitivity	25	SCH-Q/HU	1/2	16-QAM	50	HT200	-103		4,80	5,38	9 983
Sensitivity	25	SCH-Q/HU	1/2	16-QAM	100	TU50	-100 (-94)		11,10	12,43	3 895
Sensitivity	25	SCH-Q/HU	1/2	16-QAM	100	HT200	-100		4,10	4,59	11 576
Sensitivity	25	SCH-Q/HU	1/2	16-QAM	150	TU50	-99 (-93)		13,40	15,01	3 132
Sensitivity	25	SCH-Q/HU	1/2	16-QAM	150	HT200	-99		5,20	5,82	8 958
Sensitivity	25	SCH-Q/HU	1/2	64-QAM	25	TU50	-102		16,00	17,92	2 514
Sensitivity	25	SCH-Q/HU	1/2	64-QAM	25	HT200	-102		11,00	12,32	3 946
Sensitivity	25	SCH-Q/HU	1/2	64-QAM	50	TU50	-98		13,00	14,56	3 241
Sensitivity	25	SCH-Q/HU	1/2	64-QAM	50	HT200	-98		5,70	6,38	8 125
Sensitivity	25	SCH-Q/HU	1/2	64-QAM	100	TU50	-96		12,20	13,66	3 479
Sensitivity	25	SCH-Q/HU	1/2	64-QAM	100	HT200	-96		8,40	9,41	5 383
Sensitivity	25	SCH-Q/HU	1/2	64-QAM	150	TU50	-94		11,30	12,66	3 844
Sensitivity	25	SCH-Q/HU	1/2	64-QAM	150	HT200	-94		5,00	5,6	9 444
Sensitivity	25	SCH-Q/HU	2/3	64-QAM	25	TU50	-98		15,40	17,25	2 642
Sensitivity	25	SCH-Q/HU	2/3	64-QAM	25	HT200	-98		16,60	18,59	2 396
Sensitivity	25	SCH-Q/HU	2/3	64-QAM	50	TU50	-94		12,90	14,45	3 279
Sensitivity	25	SCH-Q/HU	2/3	64-QAM	50	HT200	-94		13,20	14,78	3 169
Sensitivity	25	SCH-Q/HU	2/3	64-QAM	100	TU50	-92		11,70	13,1	3 654
Sensitivity	25	SCH-Q/HU	2/3	64-QAM	100	HT200	-92		16,00	17,92	2 514
Sensitivity	25	SCH-Q/HU	2/3	64-QAM	150	TU50	-90		10,90	12,21	3 999
Sensitivity	25	SCH-Q/HU	2/3	64-QAM	150	HT200	-90		12,10	13,55	3 521
Sensitivity	26	SCH-Q/U	1/2	4-QAM	25	TU50	-111		7,00	7,84	6 564
Sensitivity	26	SCH-Q/U	1/2	4-QAM	25	HT200	-111		2,00	2,24	24 564
Sensitivity	26	SCH-Q/U	1/2	4-QAM	50	TU50	-108		8,50	9,52	5 294
Sensitivity	26	SCH-Q/U	1/2	4-QAM	50	HT200	-108		1,10	1,23	44 032
Sensitivity	26	SCH-Q/U	1/2	4-QAM	100	TU50	-105		6,80	7,62	6 834

Test type	Channel type	Logical channel	Payload code rate	Payload modulation	BW (kHz)	Propagation condition	Signal level (dBm)	Interferer level (dBm)	Spec. MER %	Test limit MER %	Minimum sample size
Sensitivity	26	SCH-Q/U	1/2	4-QAM	100	HT200	-105		0,90	1,01	57 165
Sensitivity	26	SCH-Q/U	1/2	4-QAM	150	TU50	-104		9,10	10,19	4 888
Sensitivity	26	SCH-Q/U	1/2	4-QAM	150	HT200	-104		1,60	1,79	30 321
Sensitivity	26	SCH-Q/U	1/2	16-QAM	25	TU50	-107		9,00	10,08	4 964
Sensitivity	26	SCH-Q/U	1/2	16-QAM	25	HT200	-107		5,70	6,38	8 125
Sensitivity	26	SCH-Q/U	1/2	16-QAM	50	TU50	-103		8,60	9,63	5 208
Sensitivity	26	SCH-Q/U	1/2	16-QAM	50	HT200	-103		1,40	1,57	36 097
Sensitivity	26	SCH-Q/U	1/2	16-QAM	100	TU50	-100		6,30	7,06	7 432
Sensitivity	26	SCH-Q/U	1/2	16-QAM	100	HT200	-100		1,10	1,23	44 032
Sensitivity	26	SCH-Q/U	1/2	16-QAM	150	TU50	-99		8,90	9,97	5 044
Sensitivity	26	SCH-Q/U	1/2	16-QAM	150	HT200	-99		2,50	2,8	19 524
Sensitivity	26	SCH-Q/U	1/2	64-QAM	25	TU50	-102		7,50	8,4	6 084
Sensitivity	26	SCH-Q/U	1/2	64-QAM	25	HT200	-102		6,70	7,5	6 828
Sensitivity	26	SCH-Q/U	1/2	64-QAM	50	TU50	-98		10,00	11,2	4 404
Sensitivity	26	SCH-Q/U	1/2	64-QAM	50	HT200	-98		4,80	5,38	9 983
Sensitivity	26	SCH-Q/U	1/2	64-QAM	100	TU50	-96		8,30	9,3	5 474
Sensitivity	26	SCH-Q/U	1/2	64-QAM	100	HT200	-96		4,40	4,93	10 890
Sensitivity	26	SCH-Q/U	1/2	64-QAM	150	TU50	-94		6,50	7,28	7 118
Sensitivity	26	SCH-Q/U	1/2	64-QAM	150	HT200	-94		2,90	3,25	16 910
Sensitivity	26	SCH-Q/U	2/3	64-QAM	25	TU50	-98		8,00	8,96	5 664
Sensitivity	26	SCH-Q/U	2/3	64-QAM	25	HT200	-98		16,60	18,59	2 396
Sensitivity	26	SCH-Q/U	2/3	64-QAM	50	TU50	-94		7,80	8,74	5 869
Sensitivity	26	SCH-Q/U	2/3	64-QAM	50	HT200	-94		12,50	14	3 396
Sensitivity	26	SCH-Q/U	2/3	64-QAM	100	TU50	-92		7,70	8,62	5 866
Sensitivity	26	SCH-Q/U	2/3	64-QAM	100	HT200	-92		14,00	15,68	2 964
Sensitivity	26	SCH-Q/U	2/3	64-QAM	150	TU50	-90		7,20	8,06	6 314
Sensitivity	26	SCH-Q/U	2/3	64-QAM	150	HT200	-90		15,30	17,14	2 669
Co-channel interference	26	SCH-Q/U	1/2	4-QAM	25	TU50	-86	-100	10	11,2	4 404
Co-channel interference	26	SCH-Q/U	1/2	4-QAM	25	HT200	-86	-98	10	11,2	4 404
Co-channel interference	26	SCH-Q/U	1/2	4-QAM	50	TU50	-83	-97	10	11,2	4 404
Co-channel interference	26	SCH-Q/U	1/2	4-QAM	50	HT200	-83	-95	10	11,2	4 404
Co-channel interference	26	SCH-Q/U	1/2	4-QAM	100	TU50	-80	-94	10	11,2	4 404
Co-channel interference	26	SCH-Q/U	1/2	4-QAM	100	HT200	-80	-92	10	11,2	4 404
Co-channel interference	26	SCH-Q/U	1/2	4-QAM	150	TU50	-79	-93	10	11,2	4 404
Co-channel interference	26	SCH-Q/U	1/2	4-QAM	150	HT200	-79	-91	10	11,2	4 404
Co-channel interference	26	SCH-Q/U	1/2	16-QAM	25	TU50	-82	-101	10	11,2	4 404
Co-channel interference	26	SCH-Q/U	1/2	16-QAM	25	HT200	-82	-99	10	11,2	4 404
Co-channel interference	26	SCH-Q/U	1/2	16-QAM	50	TU50	-78	-97	10	11,2	4 404
Co-channel interference	26	SCH-Q/U	1/2	16-QAM	50	HT200	-78	-95	10	11,2	4 404
Co-channel interference	26	SCH-Q/U	1/2	16-QAM	100	TU50	-75	-94	10	11,2	4 404
Co-channel interference	26	SCH-Q/U	1/2	16-QAM	100	HT200	-75	-92	10	11,2	4 404
Co-channel interference	26	SCH-Q/U	1/2	16-QAM	150	TU50	-74	-93	10	11,2	4 404
Co-channel interference	26	SCH-Q/U	1/2	16-QAM	150	HT200	-74	-91	10	11,2	4 404
Co-channel interference	26	SCH-Q/U	1/2	64-QAM	25	TU50	-77	-101	10	11,2	4 404
Co-channel interference	26	SCH-Q/U	1/2	64-QAM	25	HT200	-77	-100	10	11,2	4 404

Test type	Channel type	Logical channel	Payload code rate	Payload modulation	BW (kHz)	Propagation condition	Signal level (dBm)	Interferer level (dBm)	Spec. MER %	Test limit MER %	Minimum sample size
Co-channel interference	26	SCH-Q/U	1/2	64-QAM	50	TU50	-73	-97	10	11,2	4 404
Co-channel interference	26	SCH-Q/U	1/2	64-QAM	50	HT200	-73	-96	10	11,2	4 404
Co-channel interference	26	SCH-Q/U	1/2	64-QAM	100	TU50	-71	-95	10	11,2	4 404
Co-channel interference	26	SCH-Q/U	1/2	64-QAM	100	HT200	-71	-94	10	11,2	4 404
Co-channel interference	26	SCH-Q/U	1/2	64-QAM	150	TU50	-69	-93	10	11,2	4 404
Co-channel interference	26	SCH-Q/U	1/2	64-QAM	150	HT200	-69	-92	10	11,2	4 404
Co-channel interference	26	SCH-Q/U	2/3	64-QAM	25	TU50	-73	-100	10	11,2	4 404
Co-channel interference	26	SCH-Q/U	2/3	64-QAM	25	HT200	-73	-102	10	11,2	4 404
Co-channel interference	26	SCH-Q/U	2/3	64-QAM	50	TU50	-69	-96	10	11,2	4 404
Co-channel interference	26	SCH-Q/U	2/3	64-QAM	50	HT200	-69	-98	10	11,2	4 404
Co-channel interference	26	SCH-Q/U	2/3	64-QAM	100	TU50	-67	-94	10	11,2	4 404
Co-channel interference	26	SCH-Q/U	2/3	64-QAM	100	HT200	-67	-96	10	11,2	4 404
Co-channel interference	26	SCH-Q/U	2/3	64-QAM	150	TU50	-65	-92	10	11,2	4 404
Co-channel interference	26	SCH-Q/U	2/3	64-QAM	150	HT200	-65	-94	10	11,2	4 404

Table A.11: Test conditions for BS receiver V+D, QAM modulation, and frequencies below 700 MHz

Test type	Channel type	Logical channel	Payload code rate	Payload modulation	BW (kHz)	Propagation condition	Signal level (dBm)	Interferer level (dBm)	Spec. MER %	Test limit MER %	Minimum sample size
Sensitivity	25	SICH-Q/U	1/2	4-QAM	25	TU50	-111		5,50	6,16	8 528
Sensitivity	25	SICH-Q/U	1/2	4-QAM	25	HT200	-111		1,80	2,02	28 254
Sensitivity	25	SICH-Q/U	1/2	4-QAM	50	TU50	-108		3,60	4,03	13 259
Sensitivity	25	SICH-Q/U	1/2	4-QAM	50	HT200	-108		1,60	1,79	30 321
Sensitivity	25	SICH-Q/U	1/2	4-QAM	100	TU50	-105		3,80	4,26	12 820
Sensitivity	25	SICH-Q/U	1/2	4-QAM	100	HT200	-105		1,20	1,34	39 463
Sensitivity	25	SICH-Q/U	1/2	4-QAM	150	TU50	-104		5,30	5,94	8 970
Sensitivity	25	SICH-Q/U	1/2	4-QAM	150	HT200	-104		2,00	2,24	24 564
Sensitivity	26	SICH-Q/U	1/2	4-QAM	25	TU50	-111		3,60	4,03	13 259
Sensitivity	26	SICH-Q/U	1/2	4-QAM	25	HT200	-111		1,40	1,57	36 097
Sensitivity	26	SICH-Q/U	1/2	4-QAM	50	TU50	-108		3,50	3,92	13 764
Sensitivity	26	SICH-Q/U	1/2	4-QAM	50	HT200	-108		1,30	1,46	39 867
Sensitivity	26	SICH-Q/U	1/2	4-QAM	100	TU50	-105		3,60	4,03	13 259
Sensitivity	26	SICH-Q/U	1/2	4-QAM	100	HT200	-105		1,10	1,23	44 032
Sensitivity	26	SICH-Q/U	1/2	4-QAM	150	TU50	-104		3,90	4,37	12 378
Sensitivity	26	SICH-Q/U	1/2	4-QAM	150	HT200	-104		1,60	1,79	30 321
Sensitivity	28	SCH-Q/RA	1/2	4-QAM	25	TU50	-111		11,10	12,43	3 895
Sensitivity	28	SCH-Q/RA	1/2	4-QAM	25	HT200	-111		7,40	8,29	6 199
Sensitivity	25	SCH-Q/HU	1/2	4-QAM	25	TU50	-111		11,00	12,32	3 946
Sensitivity	25	SCH-Q/HU	1/2	4-QAM	25	HT200	-111		7,70	8,62	5 866
Sensitivity	25	SCH-Q/HU	1/2	4-QAM	50	TU50	-108		9,30	10,42	4 813
Sensitivity	25	SCH-Q/HU	1/2	4-QAM	50	HT200	-108		5,60	6,27	8 322
Sensitivity	25	SCH-Q/HU	1/2	4-QAM	100	TU50	-105		9,00	10,08	4 964
Sensitivity	25	SCH-Q/HU	1/2	4-QAM	100	HT200	-105		3,30	3,7	14 894
Sensitivity	25	SCH-Q/HU	1/2	4-QAM	150	TU50	-104		12,90	14,45	3 279
Sensitivity	25	SCH-Q/HU	1/2	4-QAM	150	HT200	-104		7,60	8,51	5 974
Sensitivity	25	SCH-Q/HU	1/2	16-QAM	25	TU50	-106 (-100)		11,90	13,33	3 608

Test type	Channel type	Logical channel	Payload code rate	Payload modulation	BW (kHz)	Propagation condition	Signal level (dBm)	Interferer level (dBm)	Spec. MER %	Test limit MER %	Minimum sample size
Sensitivity	25	SCH-Q/HU	1/2	16-QAM	25	HT200	-106		8,20	9,18	5 473
Sensitivity	25	SCH-Q/HU	1/2	16-QAM	50	TU50	-102 (-96)		7,90	8,85	5 765
Sensitivity	25	SCH-Q/HU	1/2	16-QAM	50	HT200	-102		3,60	4,03	13 259
Sensitivity	25	SCH-Q/HU	1/2	16-QAM	100	TU50	-100 (-94)		9,90	11,09	4 468
Sensitivity	25	SCH-Q/HU	1/2	16-QAM	100	HT200	-100		3,50	3,92	13 764
Sensitivity	25	SCH-Q/HU	1/2	16-QAM	150	TU50	-99 (-93)		13,20	14,78	3 169
Sensitivity	25	SCH-Q/HU	1/2	16-QAM	150	HT200	-99		7,50	8,4	6 084
Sensitivity	25	SCH-Q/HU	1/2	64-QAM	25	TU50	-101		11,00	12,32	3 946
Sensitivity	25	SCH-Q/HU	1/2	64-QAM	25	HT200	-101		7,00	7,84	6 564
Sensitivity	25	SCH-Q/HU	1/2	64-QAM	50	TU50	-98		8,90	9,97	5 044
Sensitivity	25	SCH-Q/HU	1/2	64-QAM	50	HT200	-98		4,80	5,38	9 983
Sensitivity	25	SCH-Q/HU	1/2	64-QAM	100	TU50	-95		8,70	9,74	5 124
Sensitivity	25	SCH-Q/HU	1/2	64-QAM	100	HT200	-95		3,00	3,36	16 164
Sensitivity	25	SCH-Q/HU	1/2	64-QAM	150	TU50	-94		12,10	13,55	3 521
Sensitivity	25	SCH-Q/HU	1/2	64-QAM	150	HT200	-94		6,20	6,94	7 425
Sensitivity	25	SCH-Q/HU	2/3	64-QAM	25	TU50	-98		11,20	12,54	3 845
Sensitivity	25	SCH-Q/HU	2/3	64-QAM	25	HT200	-98		11,20	12,54	3 845
Sensitivity	25	SCH-Q/HU	2/3	64-QAM	50	TU50	-94		7,80	8,74	5 869
Sensitivity	25	SCH-Q/HU	2/3	64-QAM	50	HT200	-94		7,60	8,51	5 974
Sensitivity	25	SCH-Q/HU	2/3	64-QAM	100	TU50	-92		9,90	11,09	4 468
Sensitivity	25	SCH-Q/HU	2/3	64-QAM	100	HT200	-92		7,10	7,95	6 437
Sensitivity	25	SCH-Q/HU	2/3	64-QAM	150	TU50	-91		14,10	15,79	2 933
Sensitivity	25	SCH-Q/HU	2/3	64-QAM	150	HT200	-91		11,80	13,22	3 653
Sensitivity	26	SCH-Q/U	1/2	4-QAM	25	TU50	-111		8,30	9,3	5 474
Sensitivity	26	SCH-Q/U	1/2	4-QAM	25	HT200	-111		3,70	4,14	12 788
Sensitivity	26	SCH-Q/U	1/2	4-QAM	50	TU50	-108		9,40	10,53	4 741
Sensitivity	26	SCH-Q/U	1/2	4-QAM	50	HT200	-108		2,00	2,24	24 564
Sensitivity	26	SCH-Q/U	1/2	4-QAM	100	TU50	-105		9,00	10,08	4 964
Sensitivity	26	SCH-Q/U	1/2	4-QAM	100	HT200	-105		1,50	1,68	32 964
Sensitivity	26	SCH-Q/U	1/2	4-QAM	150	TU50	-104		8,10	9,07	5 567
Sensitivity	26	SCH-Q/U	1/2	4-QAM	150	HT200	-104		3,20	3,58	14 848
Sensitivity	26	SCH-Q/U	1/2	16-QAM	25	TU50	-106		8,80	9,86	5 125
Sensitivity	26	SCH-Q/U	1/2	16-QAM	25	HT200	-106		3,90	4,37	12 378
Sensitivity	26	SCH-Q/U	1/2	16-QAM	50	TU50	-102		7,00	7,84	6 564
Sensitivity	26	SCH-Q/U	1/2	16-QAM	50	HT200	-102		1,10	1,23	44 032
Sensitivity	26	SCH-Q/U	1/2	16-QAM	100	TU50	-100		9,50	10,64	4 670
Sensitivity	26	SCH-Q/U	1/2	16-QAM	100	HT200	-100		1,60	1,79	30 321
Sensitivity	26	SCH-Q/U	1/2	16-QAM	150	TU50	-99		8,90	9,97	5 044
Sensitivity	26	SCH-Q/U	1/2	16-QAM	150	HT200	-99		3,50	3,92	13 764
Sensitivity	26	SCH-Q/U	1/2	64-QAM	25	TU50	-101		7,80	8,74	5 869
Sensitivity	26	SCH-Q/U	1/2	64-QAM	25	HT200	-101		3,70	4,14	12 788
Sensitivity	26	SCH-Q/U	1/2	64-QAM	50	TU50	-98		9,90	11,09	4 468
Sensitivity	26	SCH-Q/U	1/2	64-QAM	50	HT200	-98		3,00	3,36	16 164
Sensitivity	26	SCH-Q/U	1/2	64-QAM	100	TU50	-95		7,70	8,62	5 866
Sensitivity	26	SCH-Q/U	1/2	64-QAM	100	HT200	-95		1,60	1,79	30 321
Sensitivity	26	SCH-Q/U	1/2	64-QAM	150	TU50	-94		6,90	7,73	6 697
Sensitivity	26	SCH-Q/U	1/2	64-QAM	150	HT200	-94		2,70	3,02	17 655
Sensitivity	26	SCH-Q/U	2/3	64-QAM	25	TU50	-98		9,50	10,64	4 670
Sensitivity	26	SCH-Q/U	2/3	64-QAM	25	HT200	-98		7,70	8,62	5 866
Sensitivity	26	SCH-Q/U	2/3	64-QAM	50	TU50	-94		8,30	9,3	5 474
Sensitivity	26	SCH-Q/U	2/3	64-QAM	50	HT200	-94		4,40	4,93	10 890
Sensitivity	26	SCH-Q/U	2/3	64-QAM	100	TU50	-92		9,60	10,75	4 601
Sensitivity	26	SCH-Q/U	2/3	64-QAM	100	HT200	-92		5,10	5,71	9 195
Sensitivity	26	SCH-Q/U	2/3	64-QAM	150	TU50	-91		9,30	10,42	4 813
Sensitivity	26	SCH-Q/U	2/3	64-QAM	150	HT200	-91		8,10	9,07	5 567
Co-channel interference	26	SCH-Q/U	1/2	4-QAM	25	TU50	-86	-100	10	11,2	4 404
Co-channel interference	26	SCH-Q/U	1/2	4-QAM	25	HT200	-86	-98	10	11,2	4 404

Test type	Channel type	Logical channel	Payload code rate	Payload modulation	BW (kHz)	Propagation condition	Signal level (dBm)	Interferer level (dBm)	Spec. MER %	Test limit MER %	Minimum sample size
Co-channel interference	26	SCH-Q/U	1/2	4-QAM	50	TU50	-83	-97	10	11,2	4 404
Co-channel interference	26	SCH-Q/U	1/2	4-QAM	50	HT200	-83	-95	10	11,2	4 404
Co-channel interference	26	SCH-Q/U	1/2	4-QAM	100	TU50	-80	-94	10	11,2	4 404
Co-channel interference	26	SCH-Q/U	1/2	4-QAM	100	HT200	-80	-92	10	11,2	4 404
Co-channel interference	26	SCH-Q/U	1/2	4-QAM	150	TU50	-79	-93	10	11,2	4 404
Co-channel interference	26	SCH-Q/U	1/2	4-QAM	150	HT200	-79	-91	10	11,2	4 404
Co-channel interference	26	SCH-Q/U	1/2	16-QAM	25	TU50	-81	-100	10	11,2	4 404
Co-channel interference	26	SCH-Q/U	1/2	16-QAM	25	HT200	-81	-98	10	11,2	4 404
Co-channel interference	26	SCH-Q/U	1/2	16-QAM	50	TU50	-77	-96	10	11,2	4 404
Co-channel interference	26	SCH-Q/U	1/2	16-QAM	50	HT200	-77	-94	10	11,2	4 404
Co-channel interference	26	SCH-Q/U	1/2	16-QAM	100	TU50	-75	-94	10	11,2	4 404
Co-channel interference	26	SCH-Q/U	1/2	16-QAM	100	HT200	-75	-92	10	11,2	4 404
Co-channel interference	26	SCH-Q/U	1/2	16-QAM	150	TU50	-74	-93	10	11,2	4 404
Co-channel interference	26	SCH-Q/U	1/2	16-QAM	150	HT200	-74	-91	10	11,2	4 404
Co-channel interference	26	SCH-Q/U	1/2	64-QAM	25	TU50	-76	-99	10	11,2	4 404
Co-channel interference	26	SCH-Q/U	1/2	64-QAM	25	HT200	-76	-98	10	11,2	4 404
Co-channel interference	26	SCH-Q/U	1/2	64-QAM	50	TU50	-73	-96	10	11,2	4 404
Co-channel interference	26	SCH-Q/U	1/2	64-QAM	50	HT200	-73	-95	10	11,2	4 404
Co-channel interference	26	SCH-Q/U	1/2	64-QAM	100	TU50	-70	-93	10	11,2	4 404
Co-channel interference	26	SCH-Q/U	1/2	64-QAM	100	HT200	-70	-92	10	11,2	4 404
Co-channel interference	26	SCH-Q/U	1/2	64-QAM	150	TU50	-69	-92	10	11,2	4 404
Co-channel interference	26	SCH-Q/U	1/2	64-QAM	150	HT200	-69	-91	10	11,2	4 404
Co-channel interference	26	SCH-Q/U	2/3	64-QAM	25	TU50	-73	-100	10	11,2	4 404
Co-channel interference	26	SCH-Q/U	2/3	64-QAM	25	HT200	-73	-99	10	11,2	4 404
Co-channel interference	26	SCH-Q/U	2/3	64-QAM	50	TU50	-69	-96	10	11,2	4 404
Co-channel interference	26	SCH-Q/U	2/3	64-QAM	50	HT200	-69	-95	10	11,2	4 404
Co-channel interference	26	SCH-Q/U	2/3	64-QAM	100	TU50	-67	-94	10	11,2	4 404
Co-channel interference	26	SCH-Q/U	2/3	64-QAM	100	HT200	-67	-93	10	11,2	4 404
Co-channel interference	26	SCH-Q/U	2/3	64-QAM	150	TU50	-66	-93	10	11,2	4 404
Co-channel interference	26	SCH-Q/U	2/3	64-QAM	150	HT200	-66	-92	10	11,2	4 404

Table A.12: Test conditions for MS receiver V+D, QAM modulation

Test type	Channel type	Logical channel	Payload code rate	Payload modulation	BW (kHz)	Propagation condition	Signal level (dBm)	Interferer level (dBm)	Spec. BER or MER %	Test limit BER or MER %	Minimum sample size
Nominal error	27	SCH-Q/D	1/2	4-QAM	25	Static	-20		10	11,2	4 000
Nominal error	27	SCH-Q/D	1/2	4-QAM	50	Static	-20		10	11,2	4 000
Nominal error	27	SCH-Q/D	1/2	4-QAM	100	Static	-20		10	11,2	4 000
Nominal error	27	SCH-Q/D	1/2	4-QAM	150	Static	-20		10	11,2	4 000
Nominal error	27	SCH-Q/D	1/2	16-QAM	25	Static	-20		10	11,2	4 000
Nominal error	27	SCH-Q/D	1/2	16-QAM	50	Static	-20		10	11,2	4 000
Nominal error	27	SCH-Q/D	1/2	16-QAM	100	Static	-20		10	11,2	4 000
Nominal error	27	SCH-Q/D	1/2	16-QAM	150	Static	-20		10	11,2	4 000
Sensitivity	27	SCH-Q/D	1	4-QAM	25	Static	-113		3	3,66	4 775
Sensitivity	27	SCH-Q/D	1	4-QAM	50	Static	-110		3	3,66	4 775
Sensitivity	27	SCH-Q/D	1	4-QAM	100	Static	-107		3	3,66	4 775
Sensitivity	27	SCH-Q/D	1	4-QAM	150	Static	-105		3	3,66	4 775
Sensitivity	27	SCH-Q/D	1	16-QAM	25	Static	-106 (-100)		3	3,66	4 775
Sensitivity	27	SCH-Q/D	1	16-QAM	50	Static	-103 (-97)		3	3,66	4 775
Sensitivity	27	SCH-Q/D	1	16-QAM	100	Static	-100 (-94)		3	3,66	4 775
Sensitivity	27	SCH-Q/D	1	16-QAM	150	Static	-99 (-93)		3	3,66	4 775
Sensitivity	27	SCH-Q/D	1	64-QAM	25	Static	-101		3	3,66	4 775
Sensitivity	27	SCH-Q/D	1	64-QAM	50	Static	-97		3	3,66	4 775
Sensitivity	27	SCH-Q/D	1	64-QAM	100	Static	-95		3	3,66	4 775
Sensitivity	27	SCH-Q/D	1	64-QAM	150	Static	-93		3	3,66	4 775
Adjacent channel interference	27	SCH-Q/D	1	4-QAM	25	Static	-110	-63	3	3,66	4 775
Adjacent channel interference	27	SCH-Q/D	1	4-QAM	50	Static	-107	-65	3	3,66	4 775
Adjacent channel interference	27	SCH-Q/D	1	4-QAM	100	Static	-104	-65	3	3,66	4 775
Adjacent channel interference	27	SCH-Q/D	1	4-QAM	150	Static	-102	-65	3	3,66	4 775
Adjacent channel interference	27	SCH-Q/D	1	16-QAM	25	Static	-103 (-97)	-63 (-67)	3	3,66	4 775
Adjacent channel interference	27	SCH-Q/D	1	16-QAM	50	Static	-100 (-94)	-65 (-69)	3	3,66	4 775
Adjacent channel interference	27	SCH-Q/D	1	16-QAM	100	Static	-97 (-91)	-65 (-69)	3	3,66	4 775
Adjacent channel interference	27	SCH-Q/D	1	16-QAM	150	Static	-96 (-90)	-65 (-69)	3	3,66	4 775
Adjacent channel interference	27	SCH-Q/D	1	64-QAM	25	Static	-98	-63	3	3,66	4 775
Adjacent channel interference	27	SCH-Q/D	1	64-QAM	50	Static	-94	-65	3	3,66	4 775

Test type	Channel type	Logical channel	Payload code rate	Payload modulation	BW (kHz)	Propagation condition	Signal level (dBm)	Interferer level (dBm)	Spec. BER or MER %	Test limit BER or MER %	Minimum sample size
Adjacent channel interference	27	SCH-Q/D	1	64-QAM	100	Static	-92	-65	3	3,66	4 775
Adjacent channel interference	27	SCH-Q/D	1	64-QAM	150	Static	-90	-65	3	3,66	4 775
Blocking	27	SCH-Q/D	1	4-QAM	25	Static	-110	-40	3	3,66	4 775
Blocking	27	SCH-Q/D	1	4-QAM	25	Static	-110	-35	3	3,66	4 775
Blocking	27	SCH-Q/D	1	4-QAM	25	Static	-110	-30	3	3,66	4 775
Blocking	27	SCH-Q/D	1	4-QAM	25	Static	-110	-25	3	3,66	4 775
Blocking	27	SCH-Q/D	1	4-QAM	50	Static	-107	-40	3	3,66	4 775
Blocking	27	SCH-Q/D	1	4-QAM	50	Static	-107	-35	3	3,66	4 775
Blocking	27	SCH-Q/D	1	4-QAM	50	Static	-107	-30	3	3,66	4 775
Blocking	27	SCH-Q/D	1	4-QAM	50	Static	-107	-25	3	3,66	4 775
Blocking	27	SCH-Q/D	1	4-QAM	100	Static	-104	-40	3	3,66	4 775
Blocking	27	SCH-Q/D	1	4-QAM	100	Static	-104	-35	3	3,66	4 775
Blocking	27	SCH-Q/D	1	4-QAM	100	Static	-104	-30	3	3,66	4 775
Blocking	27	SCH-Q/D	1	4-QAM	100	Static	-104	-25	3	3,66	4 775
Blocking	27	SCH-Q/D	1	4-QAM	150	Static	-102	-40	3	3,66	4 775
Blocking	27	SCH-Q/D	1	4-QAM	150	Static	-102	-35	3	3,66	4 775
Blocking	27	SCH-Q/D	1	4-QAM	150	Static	-102	-30	3	3,66	4 775
Blocking	27	SCH-Q/D	1	4-QAM	150	Static	-102	-25	3	3,66	4 775
Blocking	27	SCH-Q/D	1	16-QAM	25	Static	-103	-40	3	3,66	4 775
Blocking	27	SCH-Q/D	1	16-QAM	25	Static	-103	-35	3	3,66	4 775
Blocking	27	SCH-Q/D	1	16-QAM	25	Static	-103	-30	3	3,66	4 775
Blocking	27	SCH-Q/D	1	16-QAM	25	Static	-103	-25	3	3,66	4 775
Blocking	27	SCH-Q/D	1	16-QAM	50	Static	-100	-40	3	3,66	4 775
Blocking	27	SCH-Q/D	1	16-QAM	50	Static	-100	-35	3	3,66	4 775
Blocking	27	SCH-Q/D	1	16-QAM	50	Static	-100	-30	3	3,66	4 775
Blocking	27	SCH-Q/D	1	16-QAM	50	Static	-100	-25	3	3,66	4 775
Blocking	27	SCH-Q/D	1	16-QAM	100	Static	-97	-40	3	3,66	4 775
Blocking	27	SCH-Q/D	1	16-QAM	100	Static	-97	-35	3	3,66	4 775
Blocking	27	SCH-Q/D	1	16-QAM	100	Static	-97	-30	3	3,66	4 775
Blocking	27	SCH-Q/D	1	16-QAM	100	Static	-97	-25	3	3,66	4 775
Blocking	27	SCH-Q/D	1	16-QAM	150	Static	-96	-40	3	3,66	4 775
Blocking	27	SCH-Q/D	1	16-QAM	150	Static	-96	-35	3	3,66	4 775
Blocking	27	SCH-Q/D	1	16-QAM	150	Static	-96	-30	3	3,66	4 775
Blocking	27	SCH-Q/D	1	16-QAM	150	Static	-96	-25	3	3,66	4 775
Blocking	27	SCH-Q/D	1	64-QAM	25	Static	-98	-40	3	3,66	4 775
Blocking	27	SCH-Q/D	1	64-QAM	25	Static	-98	-35	3	3,66	4 775
Blocking	27	SCH-Q/D	1	64-QAM	25	Static	-98	-30	3	3,66	4 775
Blocking	27	SCH-Q/D	1	64-QAM	25	Static	-98	-25	3	3,66	4 775
Blocking	27	SCH-Q/D	1	64-QAM	50	Static	-94	-40	3	3,66	4 775
Blocking	27	SCH-Q/D	1	64-QAM	50	Static	-94	-35	3	3,66	4 775
Blocking	27	SCH-Q/D	1	64-QAM	50	Static	-94	-30	3	3,66	4 775
Blocking	27	SCH-Q/D	1	64-QAM	50	Static	-94	-25	3	3,66	4 775
Blocking	27	SCH-Q/D	1	64-QAM	100	Static	-92	-40	3	3,66	4 775
Blocking	27	SCH-Q/D	1	64-QAM	100	Static	-92	-35	3	3,66	4 775
Blocking	27	SCH-Q/D	1	64-QAM	100	Static	-92	-30	3	3,66	4 775
Blocking	27	SCH-Q/D	1	64-QAM	100	Static	-92	-25	3	3,66	4 775
Blocking	27	SCH-Q/D	1	64-QAM	150	Static	-90	-40	3	3,66	4 775
Blocking	27	SCH-Q/D	1	64-QAM	150	Static	-90	-35	3	3,66	4 775
Blocking	27	SCH-Q/D	1	64-QAM	150	Static	-90	-30	3	3,66	4 775
Blocking	27	SCH-Q/D	1	64-QAM	150	Static	-90	-25	3	3,66	4 775
Spurious response	27	SCH-Q/D	1	4-QAM	25	Static	-110	-45	3	3,66	4 775
Spurious response	27	SCH-Q/D	1	4-QAM	50	Static	-107	-45	3	3,66	4 775
Spurious response	27	SCH-Q/D	1	4-QAM	100	Static	-104	-45	3	3,66	4 775
Spurious response	27	SCH-Q/D	1	4-QAM	150	Static	-102	-45	3	3,66	4 775

Test type	Channel type	Logical channel	Payload code rate	Payload modulation	BW (kHz)	Propagation condition	Signal level (dBm)	Interferer level (dBm)	Spec. BER or MER %	Test limit BER or MER %	Minimum sample size
Spurious response	27	SCH-Q/D	1	16-QAM	25	Static	-103	-45	3	3,66	4 775
Spurious response	27	SCH-Q/D	1	16-QAM	50	Static	-100	-45	3	3,66	4 775
Spurious response	27	SCH-Q/D	1	16-QAM	100	Static	-97	-45	3	3,66	4 775
Spurious response	27	SCH-Q/D	1	16-QAM	150	Static	-96	-45	3	3,66	4 775
Spurious response	27	SCH-Q/D	1	64-QAM	25	Static	-98	-45	3	3,66	4 775
Spurious response	27	SCH-Q/D	1	64-QAM	50	Static	-94	-45	3	3,66	4 775
Spurious response	27	SCH-Q/D	1	64-QAM	100	Static	-92	-45	3	3,66	4 775
Spurious response	27	SCH-Q/D	1	64-QAM	150	Static	-90	-45	3	3,66	4 775
Inter-modulation	27	SCH-Q/D	1	4-QAM	25	Static	-110	-47	3	3,66	4 775
Inter-modulation	27	SCH-Q/D	1	4-QAM	50	Static	-107	-47	3	3,66	4 775
Inter-modulation	27	SCH-Q/D	1	4-QAM	100	Static	-104	-47	3	3,66	4 775
Inter-modulation	27	SCH-Q/D	1	4-QAM	150	Static	-102	-47	3	3,66	4 775
Inter-modulation	27	SCH-Q/D	1	16-QAM	25	Static	-103	-47	3	3,66	4 775
Inter-modulation	27	SCH-Q/D	1	16-QAM	50	Static	-100	-47	3	3,66	4 775
Inter-modulation	27	SCH-Q/D	1	16-QAM	100	Static	-97	-47	3	3,66	4 775
Inter-modulation	27	SCH-Q/D	1	16-QAM	150	Static	-96	-47	3	3,66	4 775
Inter-modulation	27	SCH-Q/D	1	64-QAM	25	Static	-98	-47	3	3,66	4 775
Inter-modulation	27	SCH-Q/D	1	64-QAM	50	Static	-94	-47	3	3,66	4 775
Inter-modulation	27	SCH-Q/D	1	64-QAM	100	Static	-92	-47	3	3,66	4 775
Inter-modulation	27	SCH-Q/D	1	64-QAM	150	Static	-90	-47	3	3,66	4 775

Table A.13: Test conditions for MS receiver V+D, QAM modulation, and frequencies above 700 MHz

Test type	Channel type	Logical channel	Payload code rate	Payload modulation	BW (kHz)	Propagation condition	Signal level (dBm)	Interferer Level (dBm)	Spec. MER %	Test limit MER %	Minimum sample size
Sensitivity	27	SICH-Q/D	1/2	4-QAM	25	TU50	-108 (-102)		1,40	1,57	36 097
Sensitivity	27	SICH-Q/D	1/2	4-QAM	25	HT200	-108		0,70	,78	65 877
Sensitivity	27	SICH-Q/D	1/2	4-QAM	50	TU50	-105 (-99)		1,90	2,13	26 285
Sensitivity	27	SICH-Q/D	1/2	4-QAM	50	HT200	-105		0,70	,78	65 877
Sensitivity	27	SICH-Q/D	1/2	4-QAM	100	TU50	-102 (-96)		1,70	1,9	28 060
Sensitivity	27	SICH-Q/D	1/2	4-QAM	100	HT200	-102		0,60	,67	79 532
Sensitivity	27	SICH-Q/D	1/2	4-QAM	150	TU50	-101 (-95)		2,10	2,35	23 050
Sensitivity	27	SICH-Q/D	1/2	4-QAM	150	HT200	-101		1,00	1,12	49 764

Test type	Channel type	Logical channel	Payload code rate	Payload modulation	BW (kHz)	Propagation condition	Signal level (dBm)	Interferer Level (dBm)	Spec. MER %	Test limit MER %	Minimum sample size
Sensitivity	27	AACH-Q	1/2	4-QAM	25	TU50	-108 (-102)		4,20	4,7	11 211
Sensitivity	27	AACH-Q	1/2	4-QAM	25	HT200	-108		0,70	,78	65 877
Sensitivity	27	AACH-Q	1/2	4-QAM	50	TU50	-105 (-99)		1,90	2,13	26 285
Sensitivity	27	AACH-Q	1/2	4-QAM	50	HT200	-105		0,70	,78	65 877
Sensitivity	27	AACH-Q	1/2	4-QAM	100	TU50	-102 (-96)		1,70	1,9	28 060
Sensitivity	27	AACH-Q	1/2	4-QAM	100	HT200	-102		0,60	,67	79 532
Sensitivity	27	AACH-Q	1/2	4-QAM	150	TU50	-101 (-95)		2,10	2,35	23 050
Sensitivity	27	AACH-Q	1/2	4-QAM	150	HT200	-101		1,00	1,12	49 764
Sensitivity	27	SCH-Q/D	1/2	4-QAM	25	TU50	-108		7,60	8,51	5 974
Sensitivity	27	SCH-Q/D	1/2	4-QAM	25	HT200	-108		1,70	1,9	28 060
Sensitivity	27	SCH-Q/D	1/2	4-QAM	50	TU50	-105		10,00	11,2	4 404
Sensitivity	27	SCH-Q/D	1/2	4-QAM	50	HT200	-105		0,80	,9	67 070
Sensitivity	27	SCH-Q/D	1/2	4-QAM	100	TU50	-102		7,40	8,29	6 199
Sensitivity	27	SCH-Q/D	1/2	4-QAM	100	HT200	-102		0,60	,67	79 532
Sensitivity	27	SCH-Q/D	1/2	4-QAM	150	TU50	-101		7,60	8,51	5 974
Sensitivity	27	SCH-Q/D	1/2	4-QAM	150	HT200	-101		1,40	1,57	36 097
Sensitivity	27	SCH-Q/D	1/2	16-QAM	25	TU50	-103 (-97)		7,20	8,06	6 314
Sensitivity	27	SCH-Q/D	1/2	16-QAM	25	HT200	-103		2,10	2,35	23 050
Sensitivity	27	SCH-Q/D	1/2	16-QAM	50	TU50	-100 (-94)		8,40	9,41	5 383
Sensitivity	27	SCH-Q/D	1/2	16-QAM	50	HT200	-100		0,90	1,01	57 165
Sensitivity	27	SCH-Q/D	1/2	16-QAM	100	TU50	-97 (-91)		7,20	8,06	6 314
Sensitivity	27	SCH-Q/D	1/2	16-QAM	100	HT200	-97		0,90	1,01	57 165
Sensitivity	27	SCH-Q/D	1/2	16-QAM	150	TU50	-96 (-90)		7,50	8,4	6 084
Sensitivity	27	SCH-Q/D	1/2	16-QAM	150	HT200	-96		1,70	1,9	28 060
Sensitivity	27	SCH-Q/D	1/2	64-QAM	25	TU50	-99		9,40	10,53	4 741
Sensitivity	27	SCH-Q/D	1/2	64-QAM	25	HT200	-99		5,60	6,27	8 322
Sensitivity	27	SCH-Q/D	1/2	64-QAM	50	TU50	-95		7,00	7,84	6 564
Sensitivity	27	SCH-Q/D	1/2	64-QAM	50	HT200	-95		1,80	2,02	28 254
Sensitivity	27	SCH-Q/D	1/2	64-QAM	100	TU50	-93		8,10	9,07	5 567
Sensitivity	27	SCH-Q/D	1/2	64-QAM	100	HT200	-93		2,70	3,02	17 655
Sensitivity	27	SCH-Q/D	1/2	64-QAM	150	TU50	-92		8,90	9,97	5 044
Sensitivity	27	SCH-Q/D	1/2	64-QAM	150	HT200	-92		6,00	6,72	7 764
Sensitivity	27	SCH-Q/D	2/3	64-QAM	25	TU50	-95		9,20	10,3	4 813
Sensitivity	27	SCH-Q/D	2/3	64-QAM	25	HT200	-95		18,60	20,83	2 071
Sensitivity	27	SCH-Q/D	2/3	64-QAM	50	TU50	-91		7,10	7,95	6 437
Sensitivity	27	SCH-Q/D	2/3	64-QAM	50	HT200	-91		7,90	8,85	5 765
Sensitivity	27	SCH-Q/D	2/3	64-QAM	100	TU50	-89		8,70	9,74	5 124
Sensitivity	27	SCH-Q/D	2/3	64-QAM	100	HT200	-89		11,90	13,33	3 608
Sensitivity	27	SCH-Q/D	2/3	64-QAM	150	TU50	-88		9,10	10,19	4 888
Sensitivity	27	SCH-Q/D	2/3	64-QAM	150	HT200	-88		20,70	23,18	1 794
Co-channel interference	27	SCH-Q/D	1/2	4-QAM	25	TU50	-83	-97	10	11,2	4 404
Co-channel interference	27	SCH-Q/D	1/2	4-QAM	25	HT200	-83	-95	10	11,2	4 404
Co-channel interference	27	SCH-Q/D	1/2	4-QAM	50	TU50	-80	-94	10	11,2	4 404
Co-channel interference	27	SCH-Q/D	1/2	4-QAM	50	HT200	-80	-92	10	11,2	4 404
Co-channel interference	27	SCH-Q/D	1/2	4-QAM	100	TU50	-77	-91	10	11,2	4 404
Co-channel interference	27	SCH-Q/D	1/2	4-QAM	100	HT200	-77	-89	10	11,2	4 404
Co-channel interference	27	SCH-Q/D	1/2	4-QAM	150	TU50	-76	-90	10	11,2	4 404

Test type	Channel type	Logical channel	Payload code rate	Payload modulation	BW (kHz)	Propagation condition	Signal level (dBm)	Interferer Level (dBm)	Spec. MER %	Test limit MER %	Minimum sample size
Co-channel interference	27	SCH-Q/D	1/2	4-QAM	150	HT200	-76	-88	10	11,2	4 404
Co-channel interference	27	SCH-Q/D	1/2	16-QAM	25	TU50	-78	-97	10	11,2	4 404
Co-channel interference	27	SCH-Q/D	1/2	16-QAM	25	HT200	-78	-95	10	11,2	4 404
Co-channel interference	27	SCH-Q/D	1/2	16-QAM	50	TU50	-75	-94	10	11,2	4 404
Co-channel interference	27	SCH-Q/D	1/2	16-QAM	50	HT200	-75	-92	10	11,2	4 404
Co-channel interference	27	SCH-Q/D	1/2	16-QAM	100	TU50	-72	-91	10	11,2	4 404
Co-channel interference	27	SCH-Q/D	1/2	16-QAM	100	HT200	-72	-89	10	11,2	4 404
Co-channel interference	27	SCH-Q/D	1/2	16-QAM	150	TU50	-71	-90	10	11,2	4 404
Co-channel interference	27	SCH-Q/D	1/2	16-QAM	150	HT200	-71	-88	10	11,2	4 404
Co-channel interference	27	SCH-Q/D	1/2	64-QAM	25	TU50	-74	-98	10	11,2	4 404
Co-channel interference	27	SCH-Q/D	1/2	64-QAM	25	HT200	-74	-97	10	11,2	4 404
Co-channel interference	27	SCH-Q/D	1/2	64-QAM	50	TU50	-70	-94	10	11,2	4 404
Co-channel interference	27	SCH-Q/D	1/2	64-QAM	50	HT200	-70	-93	10	11,2	4 404
Co-channel interference	27	SCH-Q/D	1/2	64-QAM	100	TU50	-68	-92	10	11,2	4 404
Co-channel interference	27	SCH-Q/D	1/2	64-QAM	100	HT200	-68	-91	10	11,2	4 404
Co-channel interference	27	SCH-Q/D	1/2	64-QAM	150	TU50	-67	-91	10	11,2	4 404
Co-channel interference	27	SCH-Q/D	1/2	64-QAM	150	HT200	-67	-90	10	11,2	4 404
Co-channel interference	27	SCH-Q/D	2/3	64-QAM	25	TU50	-70	-97	10	11,2	4 404
Co-channel interference	27	SCH-Q/D	2/3	64-QAM	25	HT200	-70	-99	10	11,2	4 404
Co-channel interference	27	SCH-Q/D	2/3	64-QAM	50	TU50	-66	-93	10	11,2	4 404
Co-channel interference	27	SCH-Q/D	2/3	64-QAM	50	HT200	-66	-95	10	11,2	4 404
Co-channel interference	27	SCH-Q/D	2/3	64-QAM	100	TU50	-64	-91	10	11,2	4 404
Co-channel interference	27	SCH-Q/D	2/3	64-QAM	100	HT200	-64	-93	10	11,2	4 404
Co-channel interference	27	SCH-Q/D	2/3	64-QAM	150	TU50	-63	-90	10	11,2	4 404
Co-channel interference	27	SCH-Q/D	2/3	64-QAM	150	HT200	-63	-92	10	11,2	4 404

Table A.14: Test conditions for MS receiver V+D, QAM modulation, and frequencies below 700 MHz

Test type	Channel type	Logical channel	Payload code rate	Payload modulation	BW (kHz)	Propagation condition	Signal Level (dBm)	Interferer level (dBm)	Spec. MER %	Test limit MER %	Minimum sample size
Sensitivity	27	SICH-Q/D	1/2	4-QAM	25	TU50	-108 (-102)		1,90	2,13	26 285
Sensitivity	27	SICH-Q/D	1/2	4-QAM	25	HT200	-108		0,80	,9	67 070
Sensitivity	27	SICH-Q/D	1/2	4-QAM	50	TU50	-105 (-99)		2,10	2,35	23 050
Sensitivity	27	SICH-Q/D	1/2	4-QAM	50	HT200	-105		0,90	1,01	57 165
Sensitivity	27	SICH-Q/D	1/2	4-QAM	100	TU50	-102 (-96)		2,10	2,35	23 050
Sensitivity	27	SICH-Q/D	1/2	4-QAM	100	HT200	-102		0,90	1,01	57 165
Sensitivity	27	SICH-Q/D	1/2	4-QAM	150	TU50	-101 (-95)		2,30	2,58	21 816
Sensitivity	27	SICH-Q/D	1/2	4-QAM	150	HT200	-101		0,90	1,01	57 165
Sensitivity	27	AACH-Q	1/2	4-QAM	25	TU50	-108 (-102)		5,80	6,5	8 134
Sensitivity	27	AACH-Q	1/2	4-QAM	25	HT200	-108		2,50	2,8	19 524
Sensitivity	27	AACH-Q	1/2	4-QAM	50	TU50	-105 (-99)		6,20	6,94	7 425
Sensitivity	27	AACH-Q	1/2	4-QAM	50	HT200	-105		2,70	3,02	17 655
Sensitivity	27	AACH-Q	1/2	4-QAM	100	TU50	-102 (-96)		6,20	6,94	7 425
Sensitivity	27	AACH-Q	1/2	4-QAM	100	HT200	-102		2,80	3,14	17 724
Sensitivity	27	AACH-Q	1/2	4-QAM	150	TU50	-101 (-95)		6,80	7,62	6 834
Sensitivity	27	AACH-Q	1/2	4-QAM	150	HT200	-101		2,80	3,14	17 724
Sensitivity	27	SCH-Q/D	1/2	4-QAM	25	TU50	-108		7,80	8,74	5 869
Sensitivity	27	SCH-Q/D	1/2	4-QAM	25	HT200	-108		2,30	2,58	21 816
Sensitivity	27	SCH-Q/D	1/2	4-QAM	50	TU50	-105		10,00	11,2	4 404
Sensitivity	27	SCH-Q/D	1/2	4-QAM	50	HT200	-105		1,80	2,02	28 254
Sensitivity	27	SCH-Q/D	1/2	4-QAM	100	TU50	-102		8,70	9,74	5 124
Sensitivity	27	SCH-Q/D	1/2	4-QAM	100	HT200	-102		1,80	2,02	28 254
Sensitivity	27	SCH-Q/D	1/2	4-QAM	150	TU50	-101		8,40	9,41	5 383
Sensitivity	27	SCH-Q/D	1/2	4-QAM	150	HT200	-101		1,80	2,02	28 254
Sensitivity	27	SCH-Q/D	1/2	16-QAM	25	TU50	-103 (-97)		8,60	9,63	5 208
Sensitivity	27	SCH-Q/D	1/2	16-QAM	25	HT200	-103		2,90	3,25	16 910
Sensitivity	27	SCH-Q/D	1/2	16-QAM	50	TU50	-100 (-94)		7,20	8,06	6 314
Sensitivity	27	SCH-Q/D	1/2	16-QAM	50	HT200	-100		1,00	1,12	49 764
Sensitivity	27	SCH-Q/D	1/2	16-QAM	100	TU50	-97 (-91)		9,00	10,08	4 964
Sensitivity	27	SCH-Q/D	1/2	16-QAM	100	HT200	-97		1,90	2,13	26 285
Sensitivity	27	SCH-Q/D	1/2	16-QAM	150	TU50	-96 (-90)		8,70	9,74	5 124
Sensitivity	27	SCH-Q/D	1/2	16-QAM	150	HT200	-96		1,80	2,02	28 254
Sensitivity	27	SCH-Q/D	1/2	64-QAM	25	TU50	-98		7,40	8,29	6 199
Sensitivity	27	SCH-Q/D	1/2	64-QAM	25	HT200	-98		2,60	2,91	18 545
Sensitivity	27	SCH-Q/D	1/2	64-QAM	50	TU50	-95		9,30	10,42	4 813
Sensitivity	27	SCH-Q/D	1/2	64-QAM	50	HT200	-95		1,90	2,13	26 285
Sensitivity	27	SCH-Q/D	1/2	64-QAM	100	TU50	-92		7,30	8,18	6 318
Sensitivity	27	SCH-Q/D	1/2	64-QAM	100	HT200	-92		1,80	2,02	28 254
Sensitivity	27	SCH-Q/D	1/2	64-QAM	150	TU50	-91		7,40	8,29	6 199
Sensitivity	27	SCH-Q/D	1/2	64-QAM	150	HT200	-91		1,60	1,79	30 321
Sensitivity	27	SCH-Q/D	2/3	64-QAM	25	TU50	-95		9,30	10,42	4 813
Sensitivity	27	SCH-Q/D	2/3	64-QAM	25	HT200	-95		6,20	6,94	7 425
Sensitivity	27	SCH-Q/D	2/3	64-QAM	50	TU50	-91		8,10	9,07	5 567
Sensitivity	27	SCH-Q/D	2/3	64-QAM	50	HT200	-91		3,00	3,36	16 164
Sensitivity	27	SCH-Q/D	2/3	64-QAM	100	TU50	-88		7,30	8,18	6 318
Sensitivity	27	SCH-Q/D	2/3	64-QAM	100	HT200	-88		3,60	4,03	13 259
Sensitivity	27	SCH-Q/D	2/3	64-QAM	150	TU50	-87		6,90	7,73	6 697
Sensitivity	27	SCH-Q/D	2/3	64-QAM	150	HT200	-87		3,90	4,37	12 378

Test type	Channel type	Logical channel	Payload code rate	Payload modulation	BW (kHz)	Propagation condition	Signal Level (dBm)	Interferer level (dBm)	Spec. MER %	Test limit MER %	Minimum sample size
Co-channel interference	27	SCH-Q/D	1/2	4-QAM	25	TU50	-83	-97	10	11,2	4 404
Co-channel interference	27	SCH-Q/D	1/2	4-QAM	25	HT200	-83	-95	10	11,2	4 404
Co-channel interference	27	SCH-Q/D	1/2	4-QAM	50	TU50	-80	-94	10	11,2	4 404
Co-channel interference	27	SCH-Q/D	1/2	4-QAM	50	HT200	-80	-92	10	11,2	4 404
Co-channel interference	27	SCH-Q/D	1/2	4-QAM	100	TU50	-77	-91	10	11,2	4 404
Co-channel interference	27	SCH-Q/D	1/2	4-QAM	100	HT200	-77	-89	10	11,2	4 404
Co-channel interference	27	SCH-Q/D	1/2	4-QAM	150	TU50	-76	-90	10	11,2	4 404
Co-channel interference	27	SCH-Q/D	1/2	4-QAM	150	HT200	-76	-88	10	11,2	4 404
Co-channel interference	27	SCH-Q/D	1/2	16-QAM	25	TU50	-78	-97	10	11,2	4 404
Co-channel interference	27	SCH-Q/D	1/2	16-QAM	25	HT200	-78	-95	10	11,2	4 404
Co-channel interference	27	SCH-Q/D	1/2	16-QAM	50	TU50	-75	-94	10	11,2	4 404
Co-channel interference	27	SCH-Q/D	1/2	16-QAM	50	HT200	-75	-92	10	11,2	4 404
Co-channel interference	27	SCH-Q/D	1/2	16-QAM	100	TU50	-72	-91	10	11,2	4 404
Co-channel interference	27	SCH-Q/D	1/2	16-QAM	100	HT200	-72	-89	10	11,2	4 404
Co-channel interference	27	SCH-Q/D	1/2	16-QAM	150	TU50	-71	-90	10	11,2	4 404
Co-channel interference	27	SCH-Q/D	1/2	16-QAM	150	HT200	-71	-88	10	11,2	4 404
Co-channel interference	27	SCH-Q/D	1/2	64-QAM	25	TU50	-73	-96	10	11,2	4 404
Co-channel interference	27	SCH-Q/D	1/2	64-QAM	25	HT200	-73	-95	10	11,2	4 404
Co-channel interference	27	SCH-Q/D	1/2	64-QAM	50	TU50	-70	-93	10	11,2	4 404
Co-channel interference	27	SCH-Q/D	1/2	64-QAM	50	HT200	-70	-92	10	11,2	4 404
Co-channel interference	27	SCH-Q/D	1/2	64-QAM	100	TU50	-67	-90	10	11,2	4 404
Co-channel interference	27	SCH-Q/D	1/2	64-QAM	100	HT200	-67	-89	10	11,2	4 404
Co-channel interference	27	SCH-Q/D	1/2	64-QAM	150	TU50	-66	-89	10	11,2	4 404
Co-channel interference	27	SCH-Q/D	1/2	64-QAM	150	HT200	-66	-88	10	11,2	4 404
Co-channel interference	27	SCH-Q/D	2/3	64-QAM	25	TU50	-70	-97	10	11,2	4 404
Co-channel interference	27	SCH-Q/D	2/3	64-QAM	25	HT200	-70	-96	10	11,2	4 404
Co-channel interference	27	SCH-Q/D	2/3	64-QAM	50	TU50	-66	-93	10	11,2	4 404
Co-channel interference	27	SCH-Q/D	2/3	64-QAM	50	HT200	-66	-92	10	11,2	4 404
Co-channel interference	27	SCH-Q/D	2/3	64-QAM	100	TU50	-63	-90	10	11,2	4 404
Co-channel interference	27	SCH-Q/D	2/3	64-QAM	100	HT200	-63	-89	10	11,2	4 404
Co-channel interference	27	SCH-Q/D	2/3	64-QAM	150	TU50	-62	-89	10	11,2	4 404
Co-channel interference	27	SCH-Q/D	2/3	64-QAM	150	HT200	-62	-88	10	11,2	4 404

Table A.15: PUEM test table, 4-QAM, 25 kHz channel

Equipment type	Channel type	Logical channel	Propagation condition	Signal level (dBm)	Spec. PUEM	Bad unit (PUEM)	Test limit (Max No. Errors)	Sample size
MS	27	SCH-Q/D AACH-Q	TU50	-108	10^{-5} $5 \cdot 10^{-4}$	$3,5 \times 10^{-4}$ 26×10^{-4}	2 8	31 200
MS	27	SICH-Q/D	TU50	-108	10^{-5}	$3,5 \times 10^{-4}$	2	31 200
BS	26	SCH-Q/U	TU50	-111	10^{-5}	$3,5 \times 10^{-4}$	2	31 200
BS	25	SCH-Q/HU	TU50	-111	10^{-5}	$3,5 \times 10^{-4}$	2	31 200
BS	28	SCH-Q/RA	TU50	-111	10^{-5}	$3,5 \times 10^{-4}$	2	31 200
BS	26	SICH-Q/U	TU50	-111	10^{-5}	$3,5 \times 10^{-4}$	2	31 200

Table A.16: PUEM test table, 4-QAM, 50 kHz channel

Equipment type	Channel type	Logical channel	Propagation condition	Signal level (dBm)	Spec. PUEM	Bad unit (PUEM)	Test limit (Max No. Errors)	Sample size
MS	27	SCH-Q/D AACH-Q	TU50	-105	10^{-5} $5 \cdot 10^{-4}$	$3,5 \times 10^{-4}$ 26×10^{-4}	2 8	31 200
MS	27	SICH-Q/D	TU50	-105	10^{-5}	$3,5 \times 10^{-4}$	2	31 200
BS	26	SCH-Q/U	TU50	-108	10^{-5}	$3,5 \times 10^{-4}$	2	31 200
BS	25	SCH-Q/HU	TU50	-108	10^{-5}	$3,5 \times 10^{-4}$	2	31 200
BS	26	SICH-Q/U	TU50	-108	10^{-5}	$3,5 \times 10^{-4}$	2	31 200

Table A.17: PUEM test table, 4-QAM, 100 kHz channel

Equipment type	Channel type	Logical channel	Propagation condition	Signal level (dBm)	Spec. PUEM	Bad unit (PUEM)	Test limit (Max No. Errors)	Sample size
MS	27	SCH-Q/D AACH-Q	TU50	-102	10^{-5} $5 \cdot 10^{-4}$	$3,5 \times 10^{-4}$ 26×10^{-4}	2 8	31 200
MS	27	SICH-Q/D	TU50	-102	10^{-5}	$3,5 \times 10^{-4}$	2	31 200
BS	26	SCH-Q/U	TU50	-105	10^{-5}	$3,5 \times 10^{-4}$	2	31 200
BS	25	SCH-Q/HU	TU50	-105	10^{-5}	$3,5 \times 10^{-4}$	2	31 200
BS	26	SICH-Q/U	TU50	-105	10^{-5}	$3,5 \times 10^{-4}$	2	31 200

Table A.18: PUEM test table, 4-QAM, 150 kHz channel

Equipment type	Channel type	Logical channel	Propagation condition	Signal level (dBm)	Spec. PUEM	Bad unit (PUEM)	Test limit (Max No. Errors)	Sample size
MS	27	SCH-Q/D AACH-Q	TU50	-101	10^{-5} $5 \cdot 10^{-4}$	$3,5 \times 10^{-4}$ 26×10^{-4}	2 8	31 200
MS	27	SICH-Q/D	TU50	-101	10^{-5}	$3,5 \times 10^{-4}$	2	31 200
BS	26	SCH-Q/U	TU50	-104	10^{-5}	$3,5 \times 10^{-4}$	2	31 200
BS	25	SCH-Q/HU	TU50	-104	10^{-5}	$3,5 \times 10^{-4}$	2	31 200
BS	26	SICH-Q/U	TU50	-104	10^{-5}	$3,5 \times 10^{-4}$	2	31 200

A.3 Test signal T1/T4, content of BSCH, BSCH-Q/T, BNCH/T and BNCH-Q/T

Tables A.19, A.20, A.21 and A.22 define the information content of the BSCH, BNCH/T, BSCH-Q/T and BNCH-Q/T bursts, used during testing as follows:

- BSCH and BNCH/T are sent by the test equipment using $\pi/4$ -DQPSK modulation, when MS performance is tested on a phase modulated channel.
- BSCH and BNCH/T are sent by the test equipment using $\pi/4$ -DQPSK modulation, when CA MS performance is tested on a QAM channel.
- BSCH and BNCH/T are sent by the BS using $\pi/4$ -DQPSK modulation, when BS performance is tested on a phase modulated channel.
- BSCH-Q/T is sent by the test equipment using QAM, when DA MS performance is tested on a QAM channel.
- BNCH-Q/T is sent by the BS using QAM, when BS performance is tested on a QAM channel.

Table A.19: Test signal T1/T4 content of the BSCH

Information element	Size (bits)	Values	Meaning
System code	4	0xxx ₂	V+D reserved
		1xxx ₂	Reserved
Base Colour Code	6	xxxxxx ₂	Any BCC value 1 to 63
Timeslot number	2	00 ₂	Timeslot 1, used when testing MS performance on a phase modulated channel
		01 ₂	Reserved
		10 ₂	Timeslot 3, used when testing CA MS performance on a QAM modulated channel
		11 ₂	Reserved
Frame number	5	10010 ₂	Frame 18
Multiframe number	6	111100 ₂	Multiframe 60
Sharing mode	2	00 ₂	Continuous transmission
TS reserved frames	3	xxx ₂	Do not care
U-plane DTX	1	x ₂	Do not care
Frame 18 extension	1	x ₂	Do not care
Reserved	1	x ₂	Do not care
Mobile Country Code	10	xxxxxxxxx ₂	Any MCC value 0 to 1 023
Mobile Network Code	14	xxxxxxx xxxxxxx ₂	Any MNC value 0 to 16 383
Neighbour Cell Broadcast	2	00 ₂	Do not care
Cell Service Level	2	00 ₂	Do not care
Late Entry	1	0 ₂	Do not care

Table A.20: Test signal T1/T4 content of the BNCH/T

Information element	Size (bits)	Values	Meaning
PDU type	2	10 ₂	Broadcast PDU
Broadcast type	2	00 ₂	SYSINFO PDU
Main carrier	12		Test signal carrier number (defined in ETSI EN 300 392-2 [1], clause 21.5.2)
Frequency band	4		Test signal carrier band (defined in ETSI EN 300 392-2 [1], clause 21.5.2)
Offset	2	xx ₂	Frequency offset (defined in ETSI EN 300 392-2 [1], clause 21.5.2)
Duplex spacing	3		Defined in ETSI EN 300 392-2 [1], clause 21.5.2
Reverse operation	1	0 ₂ 1 ₂	Normal (see ETSI EN 300 392-2 [1], clause 21.5.2) Reverse
No of common secondary control channels in use	2	00 ₂	None
MS_TXPWR_MAX_CELL	3	000 ₂ 001 ₂ 010 ₂ 011 ₂ 100 ₂ 101 ₂ 110 ₂ 111 ₂	Reserved 15 dBm 20 dBm 25 dBm 30 dBm 35 dBm 40 dBm 45 dBm
RXLEV_ACCESS_MIN	4	0000 ₂	Defined in ETSI EN 300 392-2 [1], clause 21
ACCESS_PARAMETER	4	0000 ₂ to 1111 ₂	-53 dBm to -23 dBm in 2 dB steps for subsequent power adjustments
RADIO_DOWNLINK_TIMEOUT	4	0000 ₂	Disable Radio Downlink Counter (RDC)
Tx_on	1	0 ₂ 1 ₂	Reception on Transmission on
Tx_burst_type	1	0 ₂ 1 ₂	Normal uplink burst Control uplink burst
T1_T4_burst_type	5	00000 ₂ 00001 ₂ 00010 ₂ 00011 ₂ 00100 ₂ 00101 ₂ 00110 ₂ 00111 ₂ 01000 ₂ 01001 ₂ 01010 ₂ 01011 ₂ 01100 ₂ 01101 ₂ 01110 ₂ 01111 ₂ 10000 ₂ 10001 ₂ 10010 ₂ 10011 ₂ 10100 ₂ 10101 ₂	Reserved Type 1: TCH/7,2 (downlink) Type 2: SCH/F(downlink) Type 3: BSCH +SCH/HD (downlink) Type 4: TCH/2,4 N = 1 (downlink) Type 5: Reserved, see note 1 Type 6: Reserved, see note 1 Type 7: TCH/7,2 (uplink) Type 8: SCH/F (uplink) Type 9: STCH + STCH (uplink) Type 10: TCH/2,4 N = 1 (uplink) Type 11: SCH/HU + SCH/HU (uplink) Type 12: Reserved, see note 1 Type 13: random synchronization bursts Type 14: random synchronization sub-bursts Type 15: TCH/S PRBS tests (downlink) Type 16: TCH/S PRBS tests (uplink) Type 17: TCH/4,8 N = 1 (downlink) Type 18: TCH/4,8 N = 1 (uplink) Type 19: TCH/S speech codec test (downlink) Type 20: TCH/S speech codec test (uplink) Type 21: TCH-P8/10,8

Information element	Size (bits)	Values	Meaning
		10110 ₂	Type 22: SCH-P8/HD
		10111 ₂	Type 23: SCH-P8/HU
		11000 ₂	Type 24: SCH-P8/F
		11001 ₂	Type 25: SCH-Q/HU
		11010 ₂	Type 26: SCH-Q/U
		11011 ₂	Type 27: SCH-Q/D
		11100 ₂	Type 28: SCH-Q/RA
		11101 ₂ to 11110 ₂	Reserved
		11111 ₂	Extension
Loop_back	1	0 ₂	Loopback off
		1 ₂	Loopback on
Error correction, (see note 2)	1	0 ₂	Error correction on
		1 ₂	Error correction off
Extended burst type	5	00000 ₂	Reserved
Reserved, (see note 3)	30	All bits set to 0 ₂	Reserved
QAM_payload_type (see note 4)	5	00000 ₂	4-QAM rate = 1/2
		00001 ₂	4-QAM rate = 1
		00010 ₂	16-QAM rate = 1/2
		00011 ₂	16-QAM rate = 1
		00100 ₂	64-QAM rate = 1/2
		00101 ₂	64-QAM rate = 2/3
		00110 ₂	64-QAM rate = 1
		00111 ₂ to 11111 ₂	Reserved
Carrier bandwidth (see note 4)	3	000 ₂	25 kHz
		001 ₂	50 kHz
		010 ₂	100 kHz
		011 ₂	150 kHz
		1XX ₂	Reserved
Test signal width (see note 4)	1	0 ₂	One slot test signal
		1 ₂	Four slots test signal
PRBS continuation (see note 5)	2	00 ₂	Pseudo random bit sequence continuation is undefined
		01 ₂	Pseudo random bit sequence starts on the beginning of each multiframe
		10 ₂	Pseudo random bit sequence continues from one multiframe to another
		11 ₂	Reserved
Reserved (see note 3)	26	All bits set to 0 ₂	Reserved
NOTE 1: Type 5, type 6 and type 12 were used for the retired Packet Data Optimized standard and may not be available any other purpose.			
NOTE 2: This information element is used only when testing QAM bursts and should be set to 0 when testing phase modulation bursts.			
NOTE 3: The total length is 124 for phase modulation bursts.			
NOTE 4: This information element is only used for T4 burst type 25, 26, 27 and 28 and should be set to 0 in all the other cases.			
NOTE 5: Pseudo random bit sequence continues from one slot to another, when four slots test signal is used.			

Table A.21: Test signal T4 content of the BSCH-Q/T

Information element	Size (bits)	Values	Meaning
System code	4	0xxx ₂	V+D reserved
		1xxx ₂	Reserved
Base Colour Code	6	xxxxxx ₂	Any BCC value 1 to 63
Timeslot number	2	00 ₂	Timeslot 1
Frame number	5	10010 ₂	Frame 18
Multiframe number	6	111100 ₂	Multiframe 60
Mobile Country Code	10	xxxxxxxxxx ₂	Any MCC value 0 to 1 023
Mobile Network Code	14	xxxxxxx xxxxxx ₂	Any MNC value 0 to 16 383
Main carrier	12		Test signal carrier number (defined in ETSI EN 300 392-2 [1], clause 21.5.2)
Frequency band	4		Test signal carrier band (defined in ETSI EN 300 392-2 [1], clause 21.5.2)
Offset	2	xx ₂	Frequency offset (defined in ETSI EN 300 392-2 [1], clause 21.5.2)
Duplex spacing	3		Defined in ETSI EN 300 392-2 [1], clause 21.5.2
Reverse operation	1	0 ₂	Normal (see ETSI EN 300 392-2 [1], clause 21.5.2)
		1 ₂	Reverse
MS_TXPWR_MAX_CELL	3	000 ₂	Reserved
		001 ₂	15 dBm
		010 ₂	20 dBm
		011 ₂	25 dBm
		100 ₂	30 dBm
		101 ₂	35 dBm
		110 ₂	40 dBm
111 ₂	45 dBm		
ACCESS_PARAMETER	4	0000 ₂ to 1111 ₂	-53 dBm to -23 dBm in 2 dB steps for subsequent power adjustments
Tx_on	1	0 ₂	Reception on
		1 ₂	Transmission on
Tx_burst_type	1	0 ₂	Normal uplink burst
		1 ₂	Control uplink burst
T1_T4_burst_type	5	00000 ₂ to 11000 ₂	Reserved
		11001 ₂	Type 25: SCH-Q/HU
		11010 ₂	Type 26: SCH-Q/U
		11011 ₂	Type 27: SCH-Q/D
		11100 ₂	Type 28: SCH-Q/RA
		11101 ₂ to 11110 ₂	Reserved
11111 ₂	Extension		
Loop_back	1	0 ₂	Loopback off
		1 ₂	Loopback on
Error correction	1	0 ₂	Error correction on
		1 ₂	Error correction off
QAM_payload_type	5	00000 ₂	4-QAM rate = 1/2
		00001 ₂	4-QAM rate = 1
		00010 ₂	16-QAM rate = 1/2
		00011 ₂	16-QAM rate = 1
		00100 ₂	64-QAM rate = 1/2
		00101 ₂	64-QAM rate = 2/3
		00110 ₂	64-QAM rate = 1
		00111 ₂ to 11111 ₂	Reserved
Carrier bandwidth	3	000 ₂	25 kHz
		001 ₂	50 kHz

Information element	Size (bits)	Values	Meaning
		01 ₂	100 kHz
		011 ₂	150 kHz
		1XX ₂	Reserved
Test signal width	1	0 ₂	One slot test signal
		1 ₂	Four slots test signal
PRBS continuation (see note 1)	2	00 ₂	Pseudo random bit sequence continuation is undefined
		01 ₂	Pseudo random bit sequence starts on the beginning of each multiframe
		10 ₂	Pseudo random bit sequence continues from one multiframe to another
		11 ₂	Reserved
Reserved (see note 2)	21	All bits set to 0 ₂	Reserved.

NOTE 1: Pseudo random bit sequence continues from one slot to another, when four slots test signal is used.
NOTE 2: The length of the BSCH-Q/T PDU is 117 bits.

Table A.22: Test signal T4 content of the BNCH-Q/T

Information element	Size (bits)	Values	Meaning
PDU type	2	10 ₂	Broadcast PDU
Broadcast type	2	00 ₂	SYSINFO PDU
Main carrier	12		Test signal carrier number (defined in ETSI EN 300 392-2 [1], clause 21.5.2)
Frequency band	4		Test signal carrier band (defined in ETSI EN 300 392-2 [1], clause 21.5.2)
Offset	2	xx ₂	Frequency offset (defined in ETSI EN 300 392-2 [1], clause 21.5.2)
Duplex spacing	3		Defined in ETSI EN 300 392-2 [1], clause 21.5.2
Reverse operation	1	0 ₂	Normal (see ETSI EN 300 392-2 [1], clause 21.5.2)
		1 ₂	Reverse
No of common secondary control channels in use	2	00 ₂	None
MS_TXPWR_MAX_CELL	3	000 ₂	Reserved
		001 ₂	15 dBm
		010 ₂	20 dBm
		011 ₂	25 dBm
		100 ₂	30 dBm
		101 ₂	35 dBm
		110 ₂	40 dBm
		111 ₂	45 dBm
RXLEV_ACCESS_MIN	4	0000 ₂	Defined in ETSI EN 300 392-2 [1], clause 21
ACCESS_PARAMETER	4	0000 ₂ to 1111 ₂	-53 dBm to -23 dBm in 2 dB steps for subsequent power adjustments
RADIO_DOWNLINK_TIMEOUT	4	0000 ₂	Disable Radio Downlink Counter (RDC)
Tx_on	1	0 ₂	Reception on
		1 ₂	Transmission on
Tx_burst_type	1	0 ₂	Normal uplink burst
		1 ₂	Control uplink burst
T1_T4_burst_type	5	00000 ₂ to 11000 ₂	Reserved
		11001 ₂	Type 25: SCH-Q/HU
		11010 ₂	Type 26: SCH-Q/U
		11011 ₂	Type 27: SCH-Q/D
		11100 ₂	Type 28: SCH-Q/RA
		11101 ₂ to 11110 ₂	Reserved

Information element	Size (bits)	Values	Meaning
		11111 ₂	Extension
Loop_back	1	0 ₂	Loopback off
		1 ₂	Loopback on
Error correction	1	0 ₂	Error correction on
		1 ₂	Error correction off
Extended burst type	5	00000 ₂	Reserved
Base Colour Code	6	xxxxxx ₂	Any BCC value 1 to 63
Mobile Country Code	10	xxxxxxxxxx ₂	Any MCC value 0 to 1 023
Mobile Network Code	14	xxxxxxxxxxxxxx ₂	Any MNC value 0 to 16 383
QAM_payload_type	5	00000 ₂	4-QAM rate = 1/2
		00001 ₂	4-QAM rate = 1
		00010 ₂	16-QAM rate = 1/2
		00011 ₂	16-QAM rate = 1
		00100 ₂	64-QAM rate = 1/2
		00101 ₂	64-QAM rate = 2/3
		00110 ₂	64-QAM rate = 1
		00111 ₂ to 11111 ₂	Reserved
Carrier bandwidth	3	000 ₂	25 kHz
		001 ₂	50 kHz
		010 ₂	100 kHz
		011 ₂	150 kHz
		1XX ₂	Reserved
Test signal width	1	0 ₂	One slot test signal
		1 ₂	Four slots test signal
Reserved (see note)	89	All bits set to 0 ₂	Reserved

NOTE: The total length of the PDU is 185.

Annex B (normative): Radio test system functions

B.1 Test transmitter and receiver

B.1.1 General

The task of the test transmitter/receiver is to simulate either TETRA base station or mobile station functions required while performing the test procedures on the TETRA equipment according to the clauses 8 to 10. These tasks include:

- supporting all the logical channels defined in TETRA;
- supporting the full range of transmit and receive frequencies of TETRA according to ETSI EN 300 392-2 [1], clause 6;
- supplying appropriate signals, see clause B.1.5;
- delaying the transmitted bursts in steps of less than or equal to $125/9 \mu\text{s}$, whenever required;
- measuring the nominal Tx power from the DUT in the range from +8 dBm to +48 dBm;
- activating and de-activating specific test modes in the MS, whenever required (optional feature).

B.1.2 Sampling system

B.1.2.1 General

The task of the sampling system, a subsystem of the test receiver, is to acquire a sampled version of a wanted TETRA modulated radio signal or an unwanted emission through the TETRA filter, refer to clause B.1.2.2. The acquired complex samples (I-Q base band representation) are used for modulation accuracy and power measurements.

A sampling rate of at least 4 samples per symbol duration (and per sub-carrier for QAM) is sufficient. The receive frequency of the sampling system shall be adjustable to the nominal equipment transmit frequencies with an uncertainty of $\pm 0,02$ ppm ($\pm 0,01$ ppm for frequencies above 520 MHz). Prior to sampling, frequency down conversion from RF to IF and appropriate IF filtering may take place.

The sampling system shall meet the requirements defined in the clauses B.1.2.2 to B.1.2.4.

B.1.2.2 TETRA filter

The TETRA filter is the receive filter of the sampling system, defined in clauses 5.6 and 5.7 of ETSI EN 300 392-2 [1] as a square root raised cosine filter with a roll-off factor of 0,35 and a symbol duration of $500/9 \mu\text{s}$, and additionally the requirements defined in clauses B.1.2.3 to B.1.2.5 shall be met for the sampling system. The TETRA filter shall have a minimum length of 30 symbols.

For QAM power measurements the filter is defined in ETSI EN 300 392-2 [1], clause 5.16.

B.1.2.3 Adjacent channel power measurements

The residual adjacent channel level of the test system, as measured in clause 8.3, shall not exceed the limits shown in table B.1, at the listed frequency offsets from the nominal carrier frequencies.

Table B.1: Maximum residual adjacent channel level of the test system

Frequency offset	Bandwidth of channel	Maximum level
25 kHz	25 kHz	-70 dBc
50 kHz	25 kHz	-80 dBc
75 kHz	25 kHz	-80 dBc
37,5 kHz	50 kHz	-65 dBc
62,5 kHz	50 kHz	-73 dBc
87,5 kHz	50 kHz	-75 dBc
62,5 kHz	100 kHz	-73 dBc
87,5 kHz	100 kHz	-75 dBc
112,5 kHz	100 kHz	-70 dBc
87,5 kHz	150 kHz	-75 dBc
112,5 kHz	150 kHz	-70 dBc
137,5 kHz	150 kHz	-70 dBc

B.1.2.4 Modulation accuracy measurements

The residual modulation accuracy of the test system shall meet the following limits when measuring either a continuous or discontinuous signal. The residual RMS vector error shall be less than 0,01 and the peak vector error shall be less than 0,03.

B.1.2.5 Measurement of unwanted output power in the non-active transmit state

The residual non-active power level of the test system shall not exceed -80 dBc.

B.1.3 Spectrum analyser

Spectrum analysis equipment is to be used as a power detecting device (in frequency domain) and is characterized as follows:

- frequency range: 9 kHz to 4 GHz (9 kHz to 12,75 GHz for equipment capable of operating at frequencies greater than 470 MHz);
- power level range: -80 dBm to +20 dBm;
- dynamic range: 80 dB;
- resolution bandwidths: 30 kHz, 100 kHz, 300 kHz, 1 MHz, 3 MHz;
- video bandwidths: 30 kHz, 100 kHz, 300 kHz, 1 MHz, 3 MHz;
- peak hold function selectable.

The present document may be achieved using a combination of equipment, for instance frequency down-converters and attenuators.

B.1.4 Error rate tester

The task of the error rate tester is to measure test bit sequences which have been received by the receiver under test in the T1 test signal. A Pseudo Random Bit Sequence (PRBS) with a length of 511 bits shall be used according to Recommendation ITU-T O.153 [2]. The measurement task is to compare the bits decoded by the receiver under test with the original ones and calculate the appropriate error rates.

B.1.5 Test signal requirements

B.1.5.1 On channel test signal T1

Modulation:	TETRA $\pi/4$ -DQPSK or $\pi/8$ -D8PSK Modulated (see test signal T1 in clause 5.3). The RMS vector error and the peak vector error in any burst as defined in ETSI EN 300 392-2 [1], clause 6 shall be less than 0,03 and 0,1, respectively. These errors shall be measured in a TETRA filter defined in clause B.1.2.2.
Frequency range:	TETRA MS and BS receive frequencies.
Uncertainty of frequency:	$\pm 0,02$ ppm ($\pm 0,01$ ppm for frequencies above 520 MHz).
Power level range:	-115 dBm to -20 dBm, adjustable in steps of 0,2 dB or less.
Uncertainty of power level:	See clause 11.

B.1.5.2 Interfering test signal T2

B.1.5.2.1 Phase Modulated

Modulation:	TETRA $\pi/4$ -DQPSK Modulated (see phase modulated test signal T2 in clause 5.3). The RMS vector error and the peak vector error in any burst as defined in ETSI EN 300 392-2 [1], clause 6 shall be less than 0,03 and 0,1, respectively. These errors shall be measured in a TETRA filter defined in clause B.1.2.2.
Frequency range:	TETRA MS and BS receive frequencies.
Uncertainty of frequency:	$\pm 0,2$ ppm ($\pm 0,1$ ppm for frequencies above 520 MHz).
Power level range:	-110 dBm to -50 dBm (after combiner), adjustable in steps of 1 dB or less.
Uncertainty of power level:	See clause 11.
Adjacent channel power:	The adjacent channel power of phase modulated test signal T2 shall not exceed -70 dBc at 25 kHz offset from the nominal carrier frequency, measured in a TETRA filter defined in clause B.1.2.2. This limit applies to the T2 Test signal under static propagation conditions only.

B.1.5.2.2 QAM Modulated

Modulation:	TETRA QAM Modulated (see QAM modulated test signal T2 in clause 5.3). The RMS vector error in any burst as defined in ETSI EN 300 392-2 [1], clause 6 shall be less than 0,02.
Frequency range:	TETRA MS and BS receive frequencies.
Uncertainty of frequency:	$\pm 0,02$ ppm ($\pm 0,01$ ppm for frequencies above 520 MHz).
Power level range:	-110 dBm to -50 dBm (after combiner), adjustable in steps of 1 dB or less.
Uncertainty of power level:	See clause 11.

B.1.5.3 Interfering test signal T3

Modulation:	T3 is an unmodulated RF signal (see test signal T3 in clause 5.3).
Frequency range:	10 MHz to 4 GHz.
Uncertainty of frequency:	$\pm 0,2$ ppm ($\pm 0,1$ ppm for frequencies above 520 MHz).

Power level range:	-60 dBm to -25 dBm (after combiner), adjustable in steps of 1 dB or less. Power levels up to 16 dBm are required in the MS transmit band; for transmitter intermodulation attenuation measurement only.
Uncertainty of power level:	See clause 11.
Noise:	See clause 11.

B.1.5.4 On channel test signal T4

Modulation:	TETRA QAM (see test signal T4 in clause 5.3). The RMS vector error in any burst as defined in ETSI EN 300 392-2 [1], clause 6 shall be less than 0,02. For synchronization during MS testing, frame 18 uses phase modulation. See clause B.1.5.1.
Frequency range:	TETRA MS and BS receive frequencies.
Uncertainty of frequency:	$\pm 0,02$ ppm ($\pm 0,01$ ppm for frequencies above 520 MHz).
Power level range:	-115 dBm to -20 dBm, adjustable in steps of 0,2 dB or less.
Uncertainty of power level:	See clause 11.

B.1.6 Propagation simulators

The task of the propagation simulators is to take into account the effect of the propagation conditions, as described in ETSI EN 300 392-2 [1], clause 6, while testing the receiver performance. The propagation simulators may be either internal or external to the T1 and T2 signal generators. The characteristics of the propagation simulator shall be as follows:

- uncertainty of relative path delay of the fading profile: ± 100 ns;
- uncertainty of relative amplitude level of the fading profile: $\pm 0,5$ dB;
- the fading profile of all the fading paths shall be uncorrelated.

B.1.7 Timing measurement unit

The timing measurement unit is a time interval counter within the test system. It compares the timing (training sequence) of bursts received by the test receiver with the internal timing reference of the test system. The bursts (training sequences) transmitted by the test transmitter shall be synchronized to this internal timing reference.

B.1.8 Passive test system components

The task of the passive components is to establish the appropriate interconnection of the test system and the equipment under test. The required composition and characteristics of the passive components depend on the overall implementation of the test system and are not to be defined in the present document. However, the following components may be useful herein: RF combiner, power splitter, isolating device, RF attenuators, connecting cables, mixers, filters and switches.

B.1.9 Test system controller

The test system controller co-ordinates the test system functions via an appropriate interface. It may also perform the calculations required by the test procedures and present the final test results whenever appropriate.

Annex C (normative): TETRA Test Connector Interface (TTCI)

C.1 General

Annex C defines a TETRA Test Connector Interface for use between TETRA MS/BS equipment and TETRA test equipment.

One of the facilities that may be provided by the applicant when submitting equipment for testing, is a test connector which provides decoded data output for all uplink logical channels in the case of Base Station (BS) and downlink logical channels in the case of Mobile Station (MS) to be tested.

The TETRA Test Connector Interface (TTCI) is a communication link between the test equipment and the mobile station and base station by which it is possible to automatically register the status, indications and performance of the mobile station.

Clause 4.1.1 requires the Mobile Station (MS) and Base Station (BS) only to send decoded data to the test equipment. The TETRA Test Connector Interface (TTCI) is mainly defined as a one-way protocol from the MS/BS to the test equipment, with an option for bi-directional operation. Messages from the test equipment to the MS/BS can be ignored by the MS/BS.

The definition of the TTCI is divided into three different layers. On layer 1 the use of a 25-pole socket with standard electrical characteristics for serial communication is defined. On layer 2, an extremely simple frame oriented protocol is defined. On layer 3, messages for decoded data are defined. Each layer is defined independently of the surrounding layers.

C.2 Formal aspects

- a) The TTCI is optional for the MS/BS.
- b) The TTCI is optional for the test equipment.
- c) If the TTCI is to be used in testing of an MS/BS, it shall be possible to connect the test equipment to the test connector on the MS/BS, or to an adapter connected to the same MS/BS. If an adapter is to be used, it shall be provided by the manufacturer.
- d) If the MS/BS fulfils the requirements performed with the use of a TTCI, the MS/BS is regarded as having passed the test.
- e) If the MS/BS is rejected in a test performed with TTCI, the test shall be repeated if possible on the same TETRA equipment with the device carrying the TTCI to the MS/BS removed. The MS/BS shall be regarded as fulfilling the requirements, if it then passes the test.
- f) When using the TTCI, the MS/BS does not necessarily conform to the RF requirements. Therefore, tests concerning Rx and Tx parameters on MS/BS with cabinet radiation tests for all types of MS/BS should not be performed with the use of the TTCI.

C.3 TTCl, layer 1

C.3.1 Mechanical and electrical characteristics

The TTCl interface shall use the standard 25-pin connector, with pin assignment as shown in table C.1.

Table C.1: Pin assignments for the TTCl

Pin	Function	Source
2	Transmitted data	Test equipment
3	Received data	MS/BS
7	TTCl signal ground	

The electrical characteristics of the interface shall be as described in clause C.7. If the MS/BS provider supports a different pin assignment or different electrical characteristics, it will be the provider's responsibility to provide an interface converter to the pin assignment in table C.1 and electrical characteristics described in clause C.7.

C.3.2 Transmission and reception characteristics

The TTCl uses asynchronous serial data transmission with 1 start bit (S), 8 data bits (D1 to D8), no parity and 1 stop bit (E), shown in figure C.1.

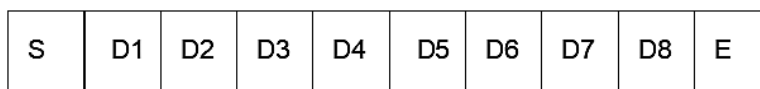

Figure C.1: Use of start and stop bits

The conditions on start and stop characters shall be as defined in Recommendation ITU-T V.1 [4]. The transmission rates are: 19 200 bits/s, 28 800 bits/s and 115 200 bit/s.

NOTE: For RF testing, the effective rate equal or greater than 19 200 bit/s supports the message as there are 68 octets (TCH+AACH) to be transferred to the test equipment between two consecutive timeslots.

C.4 TTCl, Layer 2

C.4.1 General structure

On layer 2, frames are used to carry data from higher layers. Frames consist of one or several octets. One frame with variable length is used to carry data from higher layers.

C.4.2 Frame structure

Two octets, called characters, indicate start and stop of I-frames (Information frames), shown in table C.2.

Table C.2: Frame structure

Abbreviation	Meaning	Dec. value	Bit pattern
STX	Start of data	02	0000 0010 ₂
ETX	End of data	03	0000 0011 ₂

Information from higher layers is transferred in I-frames with the structure shown in table C.3.

Table C.3: Information from higher layer in I-frames

Field name	No. of octets	Value	Start of octet no.
Start	1	Character STX	1
Length	1	Length of data (note 1)	2
Extended Length	2	Extended length of data (note 1)	3 (optional)
Data	M (note 1)	Content of data (note 2)	N (note 4)
Check	1	Error detection (note 3)	Length + N
End	1	Character ETX	Length + N + 1

NOTE 1: The total number of data octets M in the data field of the frame is calculated. The value shall be in the range of (1 to 65 535 decimal). If $M \leq 255$, the corresponding binary value is put into the Length field and the optional Extended Length field is not sent. If $M > 255$, a binary value of all 0s is put into the Length field and the corresponding binary value of M is put into the optional Extended Length field of two octets.

NOTE 2: Data to the higher layers are in the form of octets (bytes).

NOTE 3: Longitudinal checksum is created by exclusive OR on all characters starting with the Start field and ending with the last octet before the Check field. The value, one octet, is mapped into the Check field.

NOTE 4: $N = 3$ if no Extended Length is sent, $N = 5$ else.

NOTE: For all phase modulation decoded logical channels the optional Extended Length information element is not used.

C.4.3 Flow of I-frames on layer 2

C.4.3.1 Transmission of frames

A multiple frame starts with the first octet being the character STX and stops with the last octet with the content ETX, shown in figure C.2. The time between the start bits of two consecutive octets shall not be longer than T_{22} .



Figure C.2: The time between the start bits of two consecutive octets

The time between two frames is measured from the start bit of the last octet on the n^{th} frame to the start bit of the first octet of the $n+1^{\text{st}}$ frame, shown in figure C.3. The time between two consecutive frames shall not be less than T_{23} .

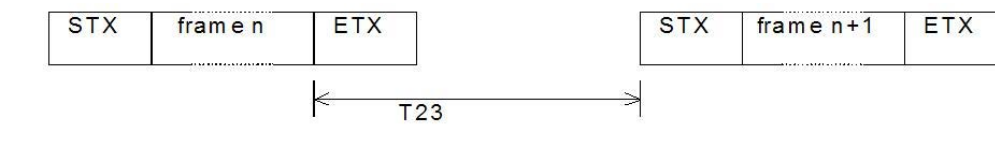

Figure C.3: The time between two consecutive frames

C.4.3.2 Reception of frames

Start of frame is defined as (more than $2 \times$ time T_{22} since reception of previous octet) AND (reception of STX). End of frame is defined as (Reception of ETX in octet number (length+3)) OR (more than $2 \times$ time T_{22} since reception of previous octet).

C.4.3.3 Parameters on layer 2

Layer 2 parameters T22 and T23 are defined in table C.4.

Table C.4: Timer values on layer 2

Bit rate	Value of T22	Value of T23
19 200	0,8 ms	1,8 ms
28 800	0,53 ms	1,2 ms
115 200	0,13 ms	0,3 ms

C.5 TTCI, Layer 3

C.5.1 Message structure

Messages are used on layer 3. They are defined by Message Identifier (MI) in the range of (0 to 255). The MI is always the first octet of the message. Table C.5 defines the usage of the TTCI Message Identifiers.

Table C.5: Use of message identifiers

MI value	Use
0 to 49	Not used in TETRA.
50 to 119	Not used in TETRA.
120 to 179	TETRA General messages. All undefined messages are reserved for TETRA future use.
180 to 209	Not used in TETRA.
210 to 239	Not used in TETRA.
240 to 255	Reserved for Layer 3 error handling. All undefined values reserved for future use.

Table C.6 lists the MI values used in TETRA to send messages from the MS/BS to the test equipment.

Table C.6: Block types

MI value	Abbr.	Meaning
120	DATO	Data output from the MS/BS to the test equipment. Contains the information received in the logical channel under testing. Preceded by one byte of status to indicate Message Error Flag and the channel type.
121	CONTROL	Control commands from the test equipment to BS contains control information about power levels and carrier frequency of BS.
122	CODEC	Codec conformance testing.
123	MS sync	Optional indicator for successful decoding of transmitted synchronization bursts.
240	ST indicator	Status Detected, in MS or BS.

C.5.2 Definitions of the messages

C.5.2.1 DATO

C.5.2.1.0 Decoded information

This message shown in table C.7 is used by the MS and the BS to send the bits extracted from the logical channel under test to the test equipment. In addition, the first octet of the message will contain the Message Error Flag octet. The test equipment shall record those instances when a message error occurred, but the Message Error Flag was not set. This can be used by the test equipment to calculate the MER and PUEM. If the last octet is not full, the rest of the octet is regarded as do not care.

For phase modulation, the AACH decoded information will be available on the test connector following the logical channel(s) information regardless of the channel type tested. In frame 18 the AACH decoded information will also be available following the BSCH and BNCH/T information.

For QAM modulation, the AACH-Q and SICH-Q/D (in case of MS testing) or the SICH-Q/U (in case of BS testing) decoded information will be available on the test connector following the logical channel(s) information regardless of the channel type tested.

The equipment under test shall provide on the test connector, together with the decoded information, an indication of the CRC pass/fail result. The indication will be provided for each of the logical channels provided with a CRC and for the AACH and AACH-Q. That information will be used by the test equipment for MER or PUEM measurements.

Table C.7: Format of DATO message

Octet Number	Meaning
1	Message Identifier
2	Message Error Flag
3 (optional)	Extended channel value
N	Recovered bits 1 to 8
N+1	Recovered bits 9 to 16
etc.	etc.
N+53	Recovered bits 425 to 432
N+...	Last Octet

NOTE: N = 3 if no extended channel value, else N = 4.

The Message Error Flag octet is composed of two fields as shown in figure C.4.

bits 8 to 5	bits 4 to 1
Result	Channel

Figure C.4: Format of message error flag octet

Where **Result** specifies error found by the MS/BS as shown in table C.8 (values are in Binary).

Table C.8: Message error flag result values

Result value	Meaning
0000 ₂	No Error
0001 ₂	Lost slot
0010 ₂	Bad CRC
0011 ₂	No RSSI
0100 ₂	Out of timing
0101 ₂	General Error
0110 ₂ to 1111 ₂	Reserved

and the **Channel** is as shown in table C.9 (values are in Binary).

Table C.9: Message error flag channel values

Channel value	Meaning
0000 ₂	TCH/7,2
0001 ₂	TCH/4,8
0010 ₂	TCH/2,4
0011 ₂	TCH/S
0100 ₂	AACH
0101 ₂	BSCH
0110 ₂	BNCH
0111 ₂	SCH/F
1000 ₂	SCH/HD
1001 ₂	SCH/HU
1010 ₂	STCH
1011 ₂	SCH-P8/HD
1100 ₂	SCH-P8/HU
1101 ₂	TCH-P8/10,8
1110 ₂	SCH-P8/F
1111 ₂	Extended

NOTE: For all phase modulation decoded logical channels the optional Extended channel information element is not used.

Table C.10: Extended channel values

Extended channel value	Meaning
00000000 ₂	SICH-Q/D
00000001 ₂	SICH-Q/U
00000010 ₂	SCH-Q/D
00000011 ₂	SCH-Q/U
00000100 ₂	SCH-Q/HU
00000101 ₂	SCH-Q/RA
00000110 ₂	AACH-Q
00000111 ₂ to 11111111 ₂	Reserved

C.5.2.1.1 Test equipment error handling

The test equipment will handle DATO messages with result 1, result 3, result 4, result 5 as a slot in which all the decoded information was erroneous and the device under test detected it as a bad slot.

The test equipment will handle DATO messages with result 2 as a slot with partial data erroneous. It shall use the information received for the BER measurement and shall use that indication for the MER/PUEM calculation.

C.5.2.2 Bi-directional operation of the TTCI

This message is optional to implement in the BS. The message is used for the test equipment to send control information to the BS.

The BS is controlled by the BNCH/T and the BS power octet as shown in table C.11. The BNCH/T is defined in table A.13. If an octet is not full, the rest of the octet is regarded as do not care.

Table C.11: Format of BS control message

Octet Number	Meaning
1	Message Identifier
2	BS power
3	BNCH/T bits 1 to 8 (PDU type - ...)
4	BNCH/T bits 9 to 16
etc.	etc.
18	BNCH/T bits 121 to 128 (... - reserved)

The BS power octet is composed of two fields, shown in figure C.5.

bits 8 to 5	bits 4 to 1
power	level

Figure C.5: Format of BS power octet

where **power** specifies that the field is used to set up power:

- 0000 = power;

and the **level** is as shown in table C.12 (values are in Binary):

Table C.12: Power level values

Level value	BS Tx power level
0000 ₂	46 dBm
0001 ₂	44 dBm
0010 ₂	42 dBm
0011 ₂	40 dBm
0100 ₂	38 dBm
0101 ₂	36 dBm
0110 ₂	34 dBm
0111 ₂	32 dBm
1000 ₂	30 dBm
1001 ₂	28 dBm

The BNCH/T message as used to control the MS can be used to control the BS. For control of a BS the MS_TXPWR_MAX_CELL, RXLEV_ACCESS_MIN and ACCESS_PARAMETER are ignored.

C.5.2.3 Codec conformance testing

This message is used by the MS and BS to send the bits extracted from the Codec under test to the TETRA system simulator. In addition, the first octet of the message, will contain the Message Error Flag octet. The test equipment shall record those instances when a message error occurred. It is optional to use the TTCI for conformance Codec testing.

For octet numbering and the meaning of the octets see clause C.5.2.1, DATO. The message error flag is defined in clause C.5.2.1, DATO. For test equipment error handling see clause C.5.2.1.1, Test equipment error handling.

C.5.2.4 ST indicator

Used by the MS/BS to indicate an internal status as shown in table C.13. The test equipment shall discard this message.

Table C.13: Format of status message

Octet Number	Meaning
1	Message Identifier
2	Status Indicator to be defined by the MS/BS manufacturer

C.6 Control of MS/BS

C.6.0 Options

One of the following options is mandatory for the MS/BS, but all options are mandatory for the test equipment:

- Manual intervention of MS/BS.
- Bi-directional operation of the test interface.
- The MS is controlled by T1.

C.6.1 Manual intervention of MS/BS

It is up to the manufacturer to provide a manual intervention to control the carrier frequency and the power levels of the MS/BS under test. If this option is used the CONTROL message may not be used.

C.6.2 Bi-directional operation of the test interface

Using the TTCI in bi-directional mode is optional. In this mode the test connector interface will work in a bi-directional mode, and the BS shall be capable of receiving the CONTROL messages on the test connector interface. Layer 1 is defined in clause C.3, and layer 2 is defined in clause C.4.

C.6.3 MS controlled by T1

In this mode the MS power settings and frequency settings are controlled by the T1 signal on the air-interface.

C.7 Characteristics of the interface

C.7.0 General

It shall be possible to connect the test equipment to the MS/BS or to an adapter connected to the MS/BS. If an adapter is to be used, it shall be provided by the manufacturer of the MS/BS.

C.7.1 Mechanical characteristics of the interface

The interface shall use a 25-pin connector, detailed in ISO 2110 [5]; the MS/BS shall use the female part.

The manufacturer may provide this interface on an external test "adapter"; the pin connection shall be as described in table C.1.

C.7.2 Electric characteristics of the interface

The state of a signal pin is defined by the voltage (v) between the pin and its associated ground as shown in table C.14.

Table C.14: Electric characteristics of the test interface

Logical state	Voltage (v)
0 or "LOW"	+5 V < v < +15 V
1 or "HIGH"	-5 V > v > -15 V
undefined	-5 V < v < +5 V
forbidden	v < -15 V, or v > +15 V

C.8 Codec testing using the TTCI

C.8.0 Options

This clause specifies a test methodology for using the TTCI for speech codec testing. It is optional to use the TTCI to perform speech codec testing.

C.8.1 Codec test methodology using the TTCI

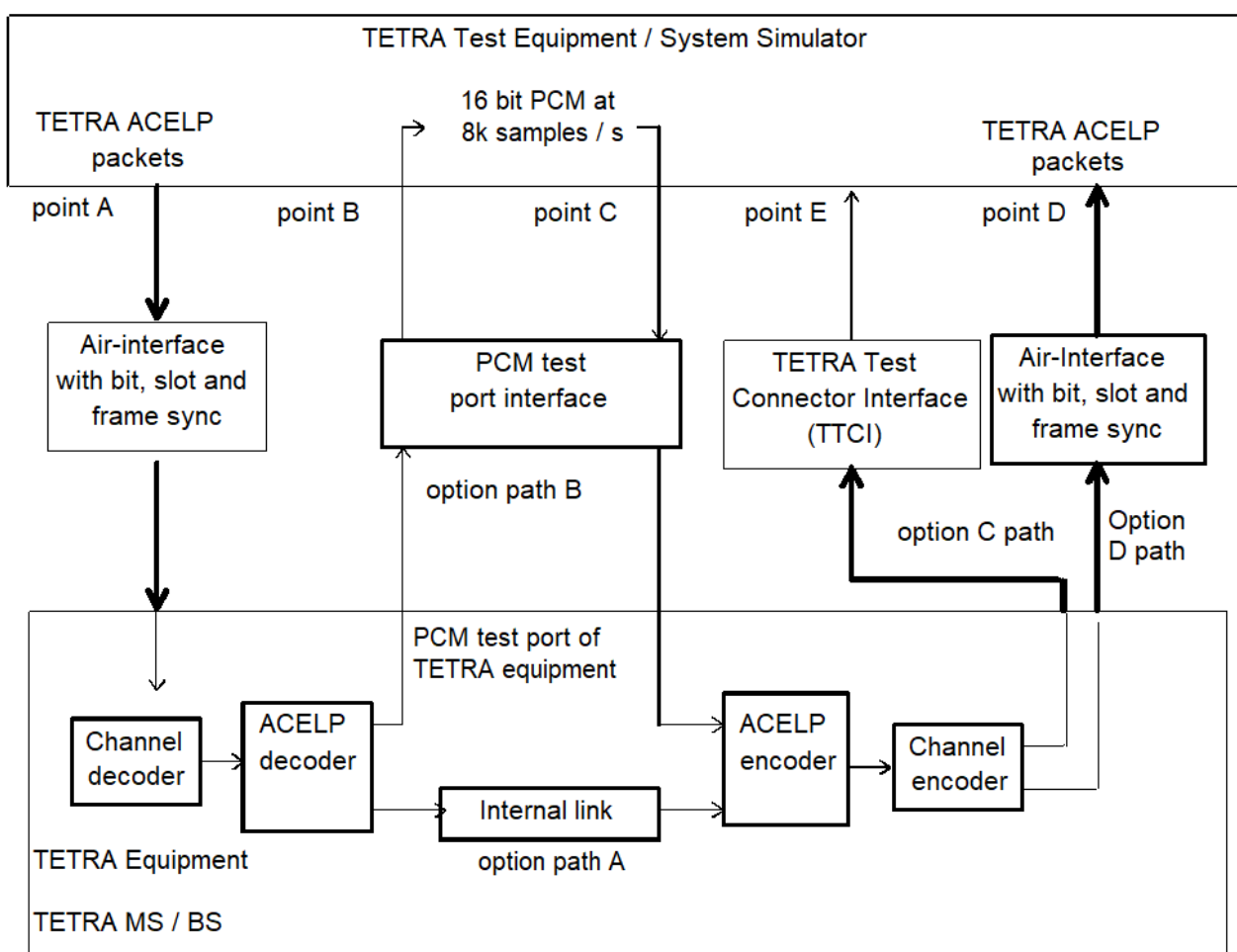

Figure C.6: TTCI and Air Interface test points for testing the MS/BS speech codec

Figure C.6 shows the various stages and blocks involved in testing the speech codec using the TTCI. As can be seen, the test sequence can be recovered from the TETRA equipment by various methods; one method is to use the air interface method, another method is to use the TTCI.

It shall be the responsibility of the TETRA equipment manufacturer together with the test facility to select the most appropriate option for recovering the test sequence.

The PCM test port as referred to in figure C.6, is not specified in the present document. However an informative implementation of this port is given in ETSI TS 101 293 [i.3], clause 10 (Digital Audio Interface).

TTCI

The injected test signal from point A can be recovered at point E using the TTCI. It is optional for the TETRA equipment manufacturers to use option path A or option path B. It is the responsibility for the TETRA equipment manufacturer together with the test facility to select the most appropriate option.

Air interface method

A description of the air interface method is given in ETSI EN 300 395-4 [6] and in annex D.

Annex D (normative): RF test facility using RF loop back

D.0 Definitions

Annex D defines a common means of testing RF parameters using an **RF loop back** facility. It includes definitions of two separate loopback test methods, **TETRA Test mode** (defined in clauses D.1 to D.6) and **T1 test mode** (defined in clauses D.7 and D.8) or T4 test mode (defined in clauses D.7 and D.9).

Clauses **D.1 to D.6** define a mandatory **TETRA Test (TT) protocol** entity for use on the air interface between a TETRA MS and a **TETRA System Simulator (TSS)** to enable the **RF loop back** to be activated. This method is intended for performing tests on production models of TETRA MS equipment. It assumes the use of a **TSS** such as a Radio Test Set or similar test equipment which is capable of exchanging air interface signalling messages with the MS under test.

An **RF loop back** facility enables manufacturing, servicing or testing to be performed without the need for test connectors or leads (except of course for antenna connections) and does not need access to authentication and encryption algorithms. The MS is tested in a state which is similar to its normal operating mode, using standard non-proprietary signalling procedures to set up voice and data calls on traffic channels.

Clauses **D.7 and D.8** define a simple **T1 test mode RF loop back** method for MS and BS equipment which does not involve any signalling protocol to provide a "virtual test connector" for performing the receiver tests specified in clause 9. This simple method is intended for the purpose of performing radio testing using the T1 Test Signal, and it allows radio tests to be performed in isolation on MS and BS equipment which may not implement the higher layers of TETRA protocol. Clauses D.7 and D.9 define a simple T4 test mode RF Loop Back method for MS and BS equipment that is similar to the T1 test mode but uses QAM modulation. The **T1 and T4 test mode RF loopback** methods are optional. Note that errors could occur due to peak power limitation, so only a physical test connector method is error free. The simple **T1 and T4 loopback test modes** do not require the **test system** to support any channel decoding or signalling, and could be implemented in the same test equipment as is used for transmission and modulation measurements. The return channels for T1 loopback are TCH/7,2 ($\pi/4$ -DQPSK) and TCH-P/10,8 ($\pi/8$ -D8PSK). For T4 loopback the return channels are SCH-Q/U and SCH-Q/D. It is only necessary for the test equipment to receive and demodulate the burst (already required for modulation measurements) and de-scramble the burst data (which is simply a bit-wise exclusive-OR operation with a known pattern).

At present the applicability of this annex is to TETRA V+D equipment. With the exception of the T4 test mode, it is also applicable to testing of Direct Mode (DMO) equipment tested in accordance with annex F.

For the purposes of this annex the following definitions apply:

- **normal operational mode:** the state a TETRA MS is in for its normal intended operation in a TETRA system when no test modes have been selected;
- **TETRA Test mode:** the state a TETRA MS is in when it has been set for TETRA Test mode and is registered to a **TETRA System Simulator (TSS)** generating a **test broadcast channel**. In this state the MS shall react to standard message sequences, as it would in **normal operational mode**, with the exceptions outlined in clause D.3.2.1, and also **TETRA Test (TT) protocol** messages;
- **TETRA loop back mode:** the sub-mode of **TETRA Test mode** when a test call has been set up and **RF loopback** is active;
- **test broadcast channel:** the Main Control Channel (MCCH) generated by a **TETRA System Simulator** using a Mobile Country Code (MCC) of 001 and a Mobile Network Code (MNC) of 001;
- **test call:** is any call sequence made when in **TETRA Test mode**. The call procedures possible shall be limited by the capability of the TETRA MS;
- **duplex test call:** a **test call** resulting in reception and transmission of a traffic channel in the same TDMA frame on a single timeslot;

- **T1 test mode:** the special test mode which MS and BS equipment is required to implement when submitted for testing, defined in clause 5.2, using the T1 test signal defined in clause 5.3.2 and either a physical test connector defined in annex C or a virtual test connector (**RF loopback**) defined in this annex. For the purposes of this annex, **T1 test mode** includes the simple **T1 loopback test mode** defined in clauses D.7 and D.8 as a virtual test connector;
- **normal T1 test mode:** the sub-mode of **T1 test mode** when **RF loopback** is not active;
- **T1 loopback test mode:** the sub-mode of **T1 test mode** when **RF loopback** is active;
- **T4 test mode:** the special test mode that MS and BS equipment is required to implement when submitted for QAM testing, defined in clause 5.2, using the T4 test signal defined in clause 5.3.5 and either a physical test connector defined in annex C or a virtual test connector (**RF loopback**) defined in this annex. Note that errors could occur due to peak power limitation, so only a physical test connector method is error free. For the purposes of this annex, **T4 test mode** includes the simple **T4 loopback test mode** defined in clauses D.7 and D.9 as a virtual test connector;
- **normal T4 test mode:** the sub-mode of **T4 test mode** when **RF loopback** is not active;
- **T4 loopback test mode:** the sub-mode of **T4 test mode** when **RF loopback** is active;
- **RF loopback:** reception at the air interface of a logical channel which is channel decoded as far as the TMV-SAP (defined in ETSI EN 300 392-2 [1], clause 19) where the output of the channel decoder is transferred to the input of a channel encoder for re-transmission at the air interface. This permits test equipment to measure receiver performance using only the antenna connector and standard non-proprietary signalling. The loopback may alternatively take place at the digital audio interface of a speech codec for the purpose of bit-exact codec testing;
- **TETRA Test protocol:** the set of air interface messages between the TSS and the MS which are used to control the operation of **TETRA Test mode** and to select and de-select the **TETRA loop back mode**. These messages are identified by a unique protocol discriminator in the MLE header;
- **TETRA System Simulator:** test equipment which is capable of generating a TETRA MCCH and a TETRA Traffic Channel (TCH) in order to simulate a TETRA BS, receiving and decoding control and traffic transmissions from a TETRA MS, and implementing sufficient TETRA protocol such that a TETRA MS under test in **TETRA Test mode** is able to perform the operations defined in annex D;
- **test system:** test equipment which is used for radio testing, including a T1 and T4 signal generator, but which does not need to exchange TETRA protocol messages with the MS or BS under test, other than the generation of BSCH/T and BNCH/T information. For the purposes of supporting **T1 and T4 loopback test mode**, the test system shall be capable of receiving, demodulating and de-scrambling TCH/7,2, TCH-P/10,8, SCH-Q/D and SCH-Q/U data in bursts transmitted by the MS or BS under test, but no other channel decoding capability is required.

D.1 Introduction to the TETRA Test (TT) protocol for RF loop back test

D.1.0 General

This clause is an introduction to the requirements for the mandatory **TETRA Test (TT) protocol** for operation over the TETRA Air Interface (AI). **This clause does not apply to the T1 test mode.**

D.1.1 Outline requirements

Prior to operation in **TETRA test mode**, it is necessary to perform some procedure to enable the use of **TETRA Test mode**.

Setting a TETRA MS into **TETRA test mode** shall be by a manual selection and may additionally be possible by a programming interface. The manual selection will depend on the user controls (if any) of the MS, and could be for example a keypad sequence, a link on an interface connector, or use of a special test SIM, as appropriate. This shall be followed by recognition of a **test broadcast channel** from a **TSS** with a MCC of 001 and a MNC of 1. The **TSS** shall require the MS to register to the **TSS**.

In **TETRA test mode** the TETRA MS shall allow **test calls** to be set up from the **TSS** or the TETRA MS and shall allow routine functions to be performed such as registration procedure and exercising some supplementary services if supported. Additionally, it shall be possible for the test system to obtain from a MS under test its equipment identity (TEI), power class, and receiver class.

With a **test call** in progress, **TETRA loop back** mode can be selected which shall configure the TETRA MS to loop back the current traffic channel to the **TSS** without access to special test connectors. This enables the **TSS** to measure receiver performance of the MS in terms of Bit Error Rate (BER) and, in the case of TCH/S, Probability of Undetected Erroneous Message (PUEM) and Message Erasure Rate (MER). The TETRA MS shall return received traffic channel data via its air interface thus also allowing RF power, burst profile, frequency and modulation accuracy measurements to be performed on the transmitter of the MS with the content of the scrambled bits of the transmitted bursts being supplied by the **TSS**.

D.1.2 Test modes

TETRA test mode shall be activated as described in clause D.3.1; in this mode the TETRA MS behaves as if it were operating in a normal TETRA environment and shall be capable of registering and placing or receiving calls to or from a **TETRA System Simulator (TSS)** as well as obeying commands from the **TSS** to change frequency channel, timeslot and MS power level. The MS shall attempt to register with the **TSS** when the **TSS** is simulating a Base Station (BS). The TETRA MS shall be able to transmit and receive all logical channels for which it has been configured. However in this mode the MS shall not use the air interface encryption, the MS shall not attempt to challenge the **TSS** for authentication, and the **TSS** shall not attempt to challenge the MS for authentication. Certain MM messages (defined in clause D.3.2.1) shall be ignored by the MS. When requested by the **TSS**, the TETRA MS shall identify itself with its TETRA Equipment Identity (TEI), power class (1, 1L, 2, 2L, 3, 3L, 4, 4L, 5 or 5L), and MS receiver class (A, B, D or E). The MS shall also supply its current TETRA Subscriber Identity (TSI) if available and applicable.

TETRA loop back mode is a sub-mode of **TETRA Test mode** and is only accessible when **TETRA Test mode** is active and a single-slot **duplex test call** is in progress. A TETRA MS capable of only simplex operation in its **normal operational mode** shall be capable of a **duplex test call** in **TETRA Test mode**, although this need not include speech codec or data terminal operations. The TETRA MS shall receive the current downlink traffic channel and after decoding as far as the TMV-SAP, re-encode and return the contents on the current uplink traffic channel, being the same type of channel as that received on the downlink. In the case of TCH/S, loop back with Bad Frame Indication (BFI) may be selected, whereby a recognizable bit pattern is returned in the event that a received and decoded speech frame indicates parity failure.

D.1.3 Switching for loop back test mode

Figure D.1 shows the functional requirements for loop back test modes. The actual physical implementation is left open to the manufacturer.

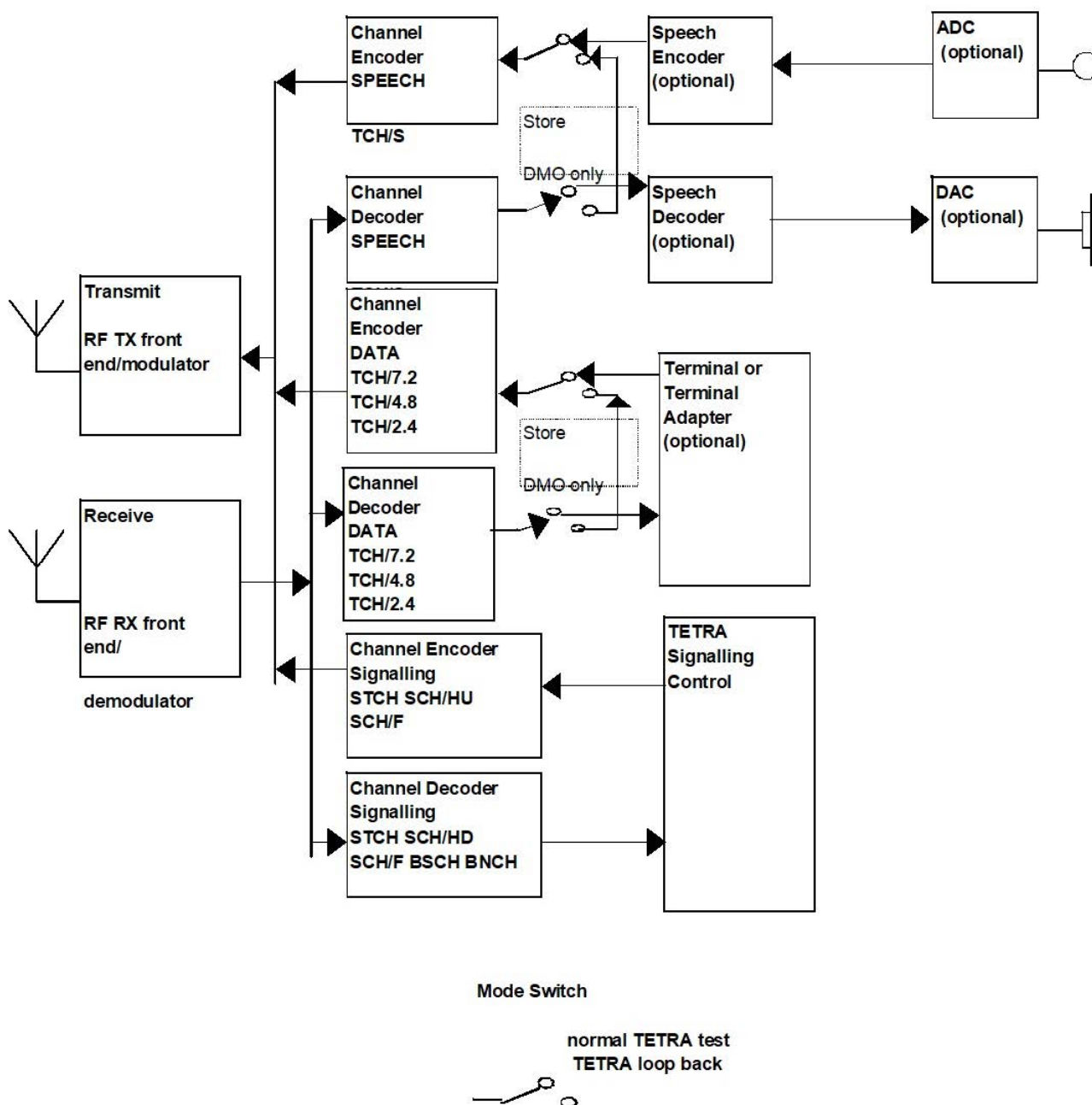

Figure D.1: Functional requirements for TETRA loop back

D.2 TETRA test entity

This clause defines the Services offered by the **TETRA Test** entity for the TETRA layer 3 Air Interface. **This clause does not apply to the T1 test mode.**

The **TETRA Test** entity shall provide access to special test procedures (defined in annex D) through a TETRA Test Service Access Point (TT-SAP), and uses the services of the Mobile Link Entity (MLE) through the **LTT-SAP**. Figure D.2 shows an overview of how the TETRA Test entity fits within the general TETRA protocol stack. During **TETRA Test mode**, interaction between the TT entity and the Mobility Management (MM) entity may be required in order to restrict the MM operation as defined in clause D.3.2.1.

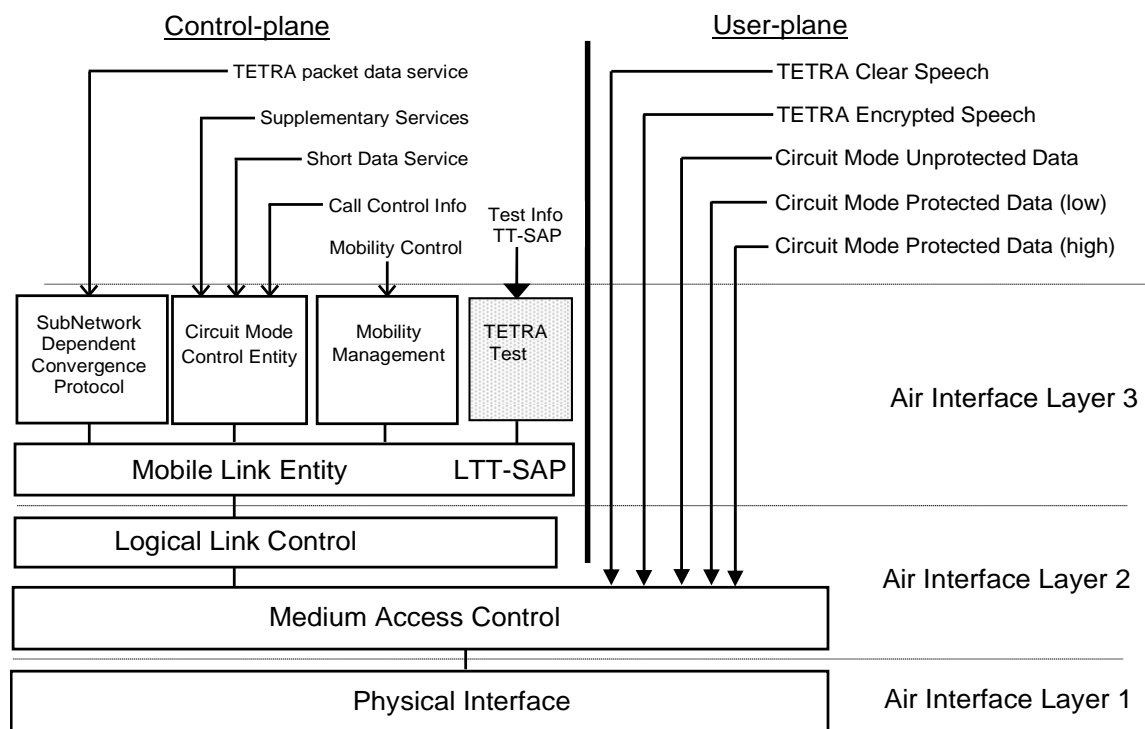

Figure D.2: Mobile station protocol stack with TETRA Test (TT) entity

D.3 TETRA RF loop back test protocol

D.3.0 Introduction

This clause defines the **TETRA Test (TT) protocol**. **This clause does not apply to the T1 test mode**. A more detailed informative description of operation is given in annex E.

D.3.1 Setting the TETRA MS into TETRA test mode

Prior to operation in **TETRA test mode**, it is necessary to perform some procedure to enable the use of **TETRA Test mode**.

Setting a TETRA MS into **TETRA test mode** shall be by a manual selection and may additionally be possible by a programming interface. The manual selection will depend on the user controls (if any) of the MS, and could be for example a keypad sequence, a link on an interface connector, or use of a special test SIM, as appropriate. This shall be followed by recognition of a **test broadcast channel** from a **TSS** with a MCC of 001 and a MNC of 1. The **TSS** shall require the MS to register to the **TSS**.

In **TETRA test mode** the TETRA MS shall allow **test calls** to be set up from the **TSS** or the TETRA MS and shall allow routine functions to be performed such as registration procedure and exercising some supplementary services if supported. Additionally, it shall be possible for the test system to obtain from a MS under test its equipment identity (TEI), power class, and receiver class.

With a **test call** in progress, **TETRA loop back** mode can be selected which shall configure the TETRA MS to loop back the current traffic channel to the **TSS** without access to special test connectors. This enables the **TSS** to measure receiver performance of the MS in terms of Bit Error Rate (BER) and, in the case of TCH/S, Probability of Undetected Erroneous Message (PUEM) and Message Erasure Rate (MER). The TETRA MS shall return received traffic channel data via its air interface thus also allowing RF power, burst profile, frequency and modulation accuracy measurements to be performed on the transmitter of the MS with the content of the scrambled bits of the transmitted bursts being supplied by the **TSS**.

D.3.2 TETRA test protocol

D.3.2.0 TETRA Test (TT) protocol discriminator

To operate the **TETRA test mode** over the air interface the **TETRA test (TT) Protocol** shall be used with the protocol discriminator reserved for test purposes in the Mobile Link Entity (MLE) protocol, defined in ETSI EN 300 392-2 [1], clause 18.5.21. The **TETRA test protocol** shall use services provided by the MLE at a **LTT-SAP**. When **TETRA test mode** is not enabled, the TETRA MS shall ignore all messages with the TETRA Test (TT) protocol discriminator.

The **TETRA Test (TT) protocol** messages are used to perform the following operations.

D.3.2.1 Confirming that TETRA test mode is set

When the TETRA MS is set into **TETRA test mode** it shall start a timer **T-TEST**. This timer is stopped when the TETRA MS is registered with the **TSS** and a D-TEST MODE CONFIRM COMMAND message is received from the **TSS**. If a D-TEST MODE CONFIRM COMMAND message is not received by the time **T-TEST** has expired then the TETRA MS shall exit **TETRA Test mode** and revert back to its **normal operational mode**. The time for **T-TEST** shall be 30 s. This allows time for cell selection and registration to the **TSS** to be completed before the D-TEST MODE CONFIRM COMMAND message is sent, but ensures that the TETRA MS returns to **normal operational mode** if **TETRA test mode** has been inadvertently selected.

A D-TEST MODE CONFIRM COMMAND message requests the TETRA MS to confirm that it has been set to **TETRA test mode**.

A U-TEST MODE CONFIRM message from the TETRA MS confirms that it is in **TETRA test mode** (or not). Parameters included with this message shall inform the **TSS** of the TEI, Power class and Receiver class (A, B, D or E) of the MS.

In **TETRA test mode** the TETRA MS shall not send an authentication challenge to the **TSS**, and the **TSS** shall not send an authentication challenge to the TETRA MS as it may not have its SIM present (if this is an option) or be programmed with its security information. Air encryption shall not be used. The following MM messages (defined in ETSI EN 300 392-2 [1], clause 16 and ETSI EN 300 392-7 [9], clause 4) shall be ignored by the MS whilst in **TETRA test mode**, and should not be sent by the TSS to the MS whilst it is in **TETRA test mode**:

- D-ATTACH/DETACH GROUP IDENTITY;
- D-ATTACH/DETACH GROUP IDENTITY ACKNOWLEDGEMENT;
- D-DISABLE;
- D-ENABLE;
- D-AUTHENTICATION DEMAND;
- D-AUTHENTICATION RESPONSE;
- D-AUTHENTICATION RESULT;
- D-OTAR.

The TETRA MS shall return a U-STATUS message with a failure indication if one of the above messages is received whilst in **TETRA test mode**.

The TETRA MS shall not send the following MM messages whilst in **TETRA test mode**:

- U-ATTACH/DETACH GROUP IDENTITY;
- U-ATTACH/DETACH GROUP IDENTITY ACKNOWLEDGEMENT;
- U-AUTHENTICATION RESPONSE;
- U-AUTHENTICATION DEMAND;
- U-AUTHENTICATION RESULT;
- U-OTAR.

The TETRA MS whilst in **TETRA test mode** shall not action the Supplementary Service (SS) procedure Dynamic Group Number Assignment (DGNA) defined in ETSI ETS 300 392-11-22 [10] and ETSI EN 300 392-12-22 [11]. The TETRA MS shall ignore an ASSIGN indication (ETSI EN 300 392-12-22 [11], clause 5.2.1). Where acknowledgement is required it shall send an ASSIGN-ACK response with the **result for assignment** element (ETSI EN 300 392-12-22 [11], clause 5.2.2) set to **rejected for any reason**.

When **TETRA test mode** has been confirmed the TETRA MS shall react to further **TETRA Test (TT) protocol** commands, as well as normal protocol commands (subject to the restrictions described above).

D.3.2.2 Operating TETRA loop back

To operate **TETRA loop back**, a **test call** shall be in an active state.

A D-LOOP COMMAND message requests the TETRA MS to go into **TETRA loop back** mode. A message parameter indicates whether to indicate errors or not (erased frames) in the case of a speech channel. Currently the present document is limited to single slot traffic channels. The TETRA MS shall ignore the D-LOOP COMMAND message if a **test call** is not active, or if **TETRA loop back** mode is already active. To change the loop back type (i.e. to switch between TCH/S with frame erasure and TCH/S without frame erasure) the **TSS** shall first end the loop back mode which is currently active.

When **TETRA loop back** is operating the TETRA MS shall be in a single slot duplex mode. It is recommended that the **TSS** does not attempt to change the traffic channel type or to assign the MS to a different frequency channel or TN during **TETRA loop back**.

A U-LOOP CONFIRM message from the TETRA MS confirms that it has set **TETRA loop back**. This message may be sent as unacknowledged data within a layer 2 Basic Link Acknowledge (BL-ACK).

A D-OPEN LOOP COMMAND message from the **TSS** requests the TETRA MS to end the current **TETRA loop back**.

A U-OPEN LOOP CONFIRM message from the TETRA MS confirms that it has ended **TETRA loop back**. This message may be sent as unacknowledged data within a layer 2 Basic Link Acknowledge (BL-ACK).

D.3.2.3 Ending TETRA test mode

TETRA test mode is terminated when the TETRA MS is powered down. It may also be terminated without powering down by some other manual action or over the air interface. On return to **normal operational mode** the TETRA MS shall behave as if it were just powered up and search for a BS with a valid MCC and MNC.

A D-TEST MODE END COMMAND message requests the TETRA MS to revert to **normal operational mode**. To reset **TETRA test mode** shall now, firstly, require the manual setting procedure.

A U-TEST MODE END CONFIRM message from the TETRA MS confirms that it is reverting to **normal operational mode**.

D.3.3 Bad frame indication

If loopback with frame erasure is active, bad frames detected in a speech channel shall be indicated by replacing the type 1-channel bits for recoding/transmission with a value not valid in normal use. This signal shall be 137 bits each set to "1" for each of speech frames A and B.

The speech channel normally carries two speech frames, A and B, which are coded together; in the event that a bad frame is detected, both A and B frames are erased. In the event that frame stealing is indicated during speech channel loopback testing, the MS shall not attempt to decode and return bits for speech frame B. It is recommended that the TSS does not use the STCH during BER/MER tests on any of the traffic channels.

D.3.4 Channels required to be looped back

Traffic channels to which this loop back mechanism applies are:

- TCH/7,2;
- TCH/4,8 and 1, 4 or 8 blocks interleaving;
- TCH/2,4 and 1, 4 or 8 blocks interleaving;
- TCH/S speech channel without Bad Frame Indication;
- TCH/S speech channel with Bad Frame Indication.

The received traffic channel after decoding, i.e. information type-1 bits in MAC blocks at the TMV-SAP, is re-encoded and returned to the TSS via the air interface. The return channel used is the same type as that received, as configured by the call set-up. For example if the received channel is a TCH/4,8 N = 4 data channel then the decoded 288 type-1 bits of the received MAC block are encoded and returned over a TCH/4,8 N = 4 channel, there will obviously be a delay in returning the signal of at least 4 frames in this case. In the case of the TCH/S, the CRC used for the returned bits is re-calculated from the actual type-1 bits to be returned, so that the information can be correctly received and decoded by the TSS.

D.3.5 TETRA loop back test scenarios

Table D.1 summarizes the expected use of the TETRA loop back facility, showing the scenarios for testing a TETRA MS when the TSS is simulating a BS.

Table D.1: MS loop back testing using TETRA test mode

MS testing	TSS configured as a BS			
	Loop back channel	Test signal	Mobile receives	Mobile transmits
TCH/7,2 TCH/4,8 TCH/2,4	TCH/x on the RF channel and TN which were set during call set-up.	TCH/x from TSS and decodes to MAC blocks at TMV-SAP.	Encodes received traffic as a TCH/x There may be a constant delay before retransmission.	A standard control frame structure for the MCCH. (note) Calls set up as normal.
TCH/S with BFI	TCH/S on the RF channel and TN which were set during call set-up.	TCH/S from TSS and decodes to MAC blocks at TMV-SAP.	Encodes received traffic as a TCH/S except that, where it detects that a received frame is in error, it sets all bits to 1 before encoding. There may be a constant delay before retransmission.	Unused slots of MCCH RF carrier filled with SCH/HD+SCH/HD (Null PDUs) or BSCH+BNCH.
TCH/S without BFI	TCH/S on the RF channel and TN which were set during call set-up.	TCH/S from TSS and decodes to MAC blocks at TMV-SAP.	Encodes received traffic as a TCH/S, even if a frame in error is detected. There may be a constant delay before retransmission.	
NOTE:	When a test call is transferred to a traffic channel on a different RF carrier it is not necessary for the TSS to continue generating an MCCH. When the TETRA equipment is returned to the idle/registered state then an MCCH will be required. This means that the TSS only requires to generate one RF carrier at a time.			

D.4 TETRA Test (TT) PDU descriptions

D.4.0 General

The TT PDUs detailed in this clause shall be visible at the Um reference point. The general format of the PDU follows that defined in ETSI EN 300 392-2 [1], clauses 14.7 and 16.9. **This clause does not apply to the T1 or T4 test mode.**

D.4.1 TT PDU description tables downlink

D.4.1.1 D-LOOP COMMAND

Message: D-LOOP COMMAND.

Response to: -

Response expected: U-LOOP CONFIRM.

Short description: The message is sent by the TSS to request a MS to loop back a channel.

Shown in table D.2.

Table D.2: D-LOOP COMMAND PDU contents

Information element	Length	Type	C/O/M	Remark
PDU Type	5	1	M	
Loopback type	5	1	M	

D.4.1.2 D-OPEN LOOP COMMAND

Message: D-OPEN LOOP COMMAND.

Response to: -

Response expected: U-OPEN LOOP CONFIRM.

Short description: This message is sent by the TSS to a MS to request that any test loop active is opened.

Shown in table D.3.

Table D.3: D-OPEN LOOP COMMAND PDU contents

Information element	Length	Type	C/O/M	Remark
PDU Type	5	1	M	

D.4.1.3 D-TEST MODE CONFIRM COMMAND

Message: D-TEST MODE CONFIRM COMMAND.

Response to: -

Response expected: U-TEST MODE CONFIRM.

Short description: This message is sent by the TSS to a MS to request confirmation that the MS is set to test mode.

Shown in table D.4.

Table D.4: D-TEST MODE CONFIRM COMMAND PDU contents

Information element	Length	Type	C/O/M	Remark
PDU Type	5	1	M	

D.4.1.4 D-TEST MODE END COMMAND

Message: D-TEST MODE END COMMAND.

Response to: -

Response expected: U-TEST MODE END CONFIRM.

Short description: This message is sent by the TSS to a MS to request it to end test mode.

Shown in table D.5.

Table D.5: D-TEST MODE END COMMAND PDU contents

Information element	Length	Type	C/O/M	Remark
PDU Type	5	1	M	

D.4.2 TT PDU description tables uplink

D.4.2.1 U-LOOP CONFIRM

Message: U-LOOP CONFIRM.

Response to: D-LOOP COMMAND.

Response expected: -

Short description: This message is sent by a MS to the TSS to confirm that it has closed the required loop. The loopback type information element is a repeat of that sent on the D-LOOP COMMAND.

Shown in table D.6.

Table D.6: U-LOOP CONFIRM PDU contents

Information element	Length	Type	C/O/M	Remark
PDU Type	5	1	M	
Loopback type	5	1	M	

D.4.2.2 U-OPEN LOOP CONFIRM

Message: U-OPEN LOOP CONFIRM.

Response to: D-OPEN LOOP COMMAND.

Response expected: -

Short description: This message is sent by a MS to the TSS to confirm that the test loop is open.

Shown in table D.7.

Table D.7: U-OPEN LOOP CONFIRM PDU contents

Information element	Length	Type	C/O/M	Remark
PDU Type	5	1	M	

D.4.2.3 U-TEST MODE CONFIRM

Message: U-TEST MODE CONFIRM.

Response to: D-TEST MODE CONFIRM COMMAND.

Response expected: -

Short description: This message is sent by a MS to the TSS to confirm that **TETRA Test mode** has been set.

Shown in table D.8.

Table D.8: U-TEST MODE CONFIRM PDU contents

Information element	Length	Type	C/O/M	Remark
PDU Type	5	1	M	
Confirm	2	1	M	
TETRA equipment identity	60	1	M	15 digit TEI
MS power class	4	1	M	
Receiver class	2	1	M	
Class of MS	24	1	M	(note)

NOTE: Class of MS element is the same as the element used in ETSI EN 300 392-2 [1], clause 16.

D.4.2.4 U-TEST MODE END CONFIRM

Message: U-TEST MODE END CONFIRM.

Response to: D-TEST MODE END COMMAND.

Response expected: -

Short description: This message is sent by a MS to the TSS to confirm that **TETRA Test mode** is ended.

Shown in table D.9.

Table D.9: U-TEST MODE END CONFIRM PDU contents

Information element	Length	Type	C/O/M	Remark
PDU Type	5	1	M	

D.4.3 Information elements coding

D.4.3.0 General applicability

Where no description exists below, then the descriptions given in ETSI EN 300 392-2 [1], clauses 14 and 16 apply.

D.4.3.1 Loopback type

The purpose of the loopback type element is to inform the TETRA MS whether to indicate frame erasures. This is shown in table D.10.

Table D.10: Loopback type IE contents

Information element	Length	Value	Remark
Loopback type	5		
Current TCH without frame erasure		00001 ₂	TCH/S, TCH/7,2, TCH/4,8, TCH/2,4
Current TCH with frame erasure		00010 ₂	Current TCH with BFI (note)

NOTE: Frame erasure only applies to TCH/S. In the case of TCH/7,2, TCH/4,8 or TCH/2,4, this value of loopback type shall be treated the same as "Current TCH without frame erasure".

D.4.3.2 Confirm

The purpose of the confirm element is to confirm that the TETRA MS is in **TETRA Test mode** or to indicate that it is not. This is shown in table D.11.

Table D.11: Confirm IE contents

Information element	Length	Value	Remark
Confirm	2	00 ₂	confirmed
		01 ₂	TETRA Test mode not set
		10 ₂	TETRA Test mode not supported
		11 ₂	reserved

D.4.3.3 MS power class

The purpose of the MS power element is to inform the TSS of the maximum power output of the MS. This is shown in table D.12.

Table D.12: MS power class IE contents

Information element	Length	Value	Remark
MS power class	4	0001 ₂	class 1: 45 dBm
		1001 ₂	class 1L: 42,5 dBm
		0010 ₂	class 2: 40 dBm
		1010 ₂	class 2L: 37,5 dBm
		0011 ₂	class 3: 35 dBm
		1011 ₂	class 3L: 32,5 dBm
		0100 ₂	class 4: 30 dBm
		1100 ₂	class 4L: 27,5 dBm
		0101 ₂	class 5: 25 dBm
1101 ₂	class 5L: 22,5 dBm		

D.4.3.4 PDU

The purpose of the PDU element is to identify the PDU type. This is shown in table D.13.

Table D.13: PDU IE contents

Information element	Length	Value	Downlink	Uplink
PDU	5	00100 ₂	D-LOOP COMMAND	
		00101 ₂		U-LOOP CONFIRM
		00111 ₂	D-OPEN LOOP COMMAND	
		01000 ₂		U-OPEN LOOP CONFIRM
		01110 ₂	D-TEST MODE CONFIRM COMMAND	
		01111 ₂		U-TEST MODE CONFIRM
		10000 ₂	D-TEST MODE END COMMAND	
		10001 ₂		U-TEST MODE END CONFIRM
		Others	Reserved	Reserved

D.4.3.5 Receiver class

The purpose of the receiver class element is to inform the TSS of the class of the MS receiver. This is shown in table D.14.

Table D.14: Receiver class IE contents

Information element	Length	Value	Remark
Receiver class	2	00 ₂	class A
		01 ₂	class B
		10 ₂	class E
		11 ₂	class D

D.5 TT use of MLE, LLC and MAC

This clause defines the use of lower layers by the **TETRA Test (TT) protocol** entity. **It does not apply to T1 or T4 test mode.**

The TT shall use the services of the Mobile Link Entity (MLE). For the TT the MLE service PDU shall use the TT protocol discriminator 111₂ followed by the TT PDU as defined in ETSI EN 300 392-2 [1], clause 18.5.2.1.

The MLE-PDUs are embedded in TL-SDUs and make use of layer 2 processes in a standard manner. The LLC (Logical Link Control) uses the Basic Link PDUs without the Frame Check Sequences (FCS) and the MAC (Medium Access Control) assembles MAC blocks for transmission. The assembly of the PDUs is shown in figure D.3.

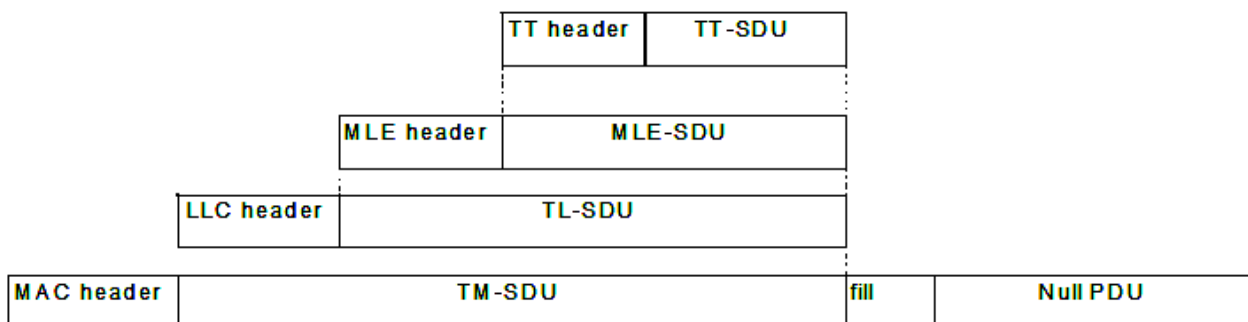

Figure D.3: Relationship between PDUs and SDUs showing how a TT-SDU fits into a MAC block

D.6 Message sequence charts and operation of TETRA loop back

This clause applies to the TETRA Test (TT) protocol. It does not apply to the T1 or T4 test mode.

Refer to annex E for an informative description of operation of TETRA loop back.

D.7 Introduction to the T1 and T4 test modes for RF loop back test

D.7.0 General

This clause is an introduction to the requirements for a **T1 and a T4 test mode** for both MS and BS equipment for operation over the TETRA Air Interface (AI). **This clause does not apply to the TETRA Test (TT) Protocol.**

D.7.1 Outline requirements

The **T1 and T4 test modes** shall provide the means to activate the **RF loop back** test facility of TETRA MS and BS equipment, thus using the AI and avoiding the use of special test connectors and their associated protocols. The T1 test mode is associated with $\pi/4$ -DQPSK and $\pi/8$ -D8PSK modulation as outlined in clause 5.3.2. The T4 test mode is associated with the QAM types of modulation as described in clause 5.3.5. It shall enable the following test functions to be performed:

- duplex operation using a single timeslot when in **T1/T4 loopback test mode**, whether or not this is possible in **normal T1/T4 test mode** or **normal operational mode**;
- enable selected received traffic and signalling channels to be decoded and then retransmitted over the air interface on a TCH/7,2 ($\pi/4$ -DQPSK), TCH-P/10,8 ($\pi/8$ -D8PSK) or SCH-Q/D or U (QAM) channel;

for TETRA equipment with speech capability (i.e. includes a speech codec):

- enable loop back of speech codec output to the speech codec input (at the 128 kb/s rate).

D.7.2 T1/T4 Test Modes

When in T1/T4 test mode the following sub-modes are required which are selected over the AI:

- **normal T1/T4 test mode:** in this mode the TETRA equipment satisfies the requirements of clause 5.2. Normal T1/T4 MS test mode is selected by the Loop_back bit of BNCH/T (table A.16) or BSCH-Q/T (table A.17) set to zero. Normal T1/T4 BS test mode is selected by the method provided by the manufacturer;
- **T1/T4 loop back test mode:** in this mode the TETRA equipment satisfies the requirements of clause 5.2.1. Additionally, the MS shall be synchronized in time and frequency to the test signal T1 or T4 and shall transmit, only in timeslot 1, TCH/7,2, TCH-P/10,8 or SCH-Q/U normal uplink bursts on frames 1 to 17 in every multiframe. The BS shall operate in its normal mode, e.g. continuous or discontinuous mode. For a BS in discontinuous mode the BS shall transmit only in timeslot 1 of each frame. The BS shall transmit, in timeslot 1, TCH/7,2, TCH-P/10,8 or SCH-Q/D normal downlink bursts on frames 1 to 17 in every multiframe. For the MS, **T1/T4 loopback test mode** is selected by the Loop_back bit of BNCH/T (table A.16) or BSCH-Q/T (table A.17) set to one, regardless of the state of the Tx_on and Tx_burst_type bits of BNCH/T or BSCH-Q/T (table A.17). For the BS, **T1/T4 loopback test mode** is selected by the method provided by the manufacturer. Note that a TETRA MS capable of only simplex operation in its normal mode of functioning shall be capable of duplex functioning in loopback T1/T4 test mode. There are two distinct loop back modes;
- **channel:** the TETRA equipment shall receive the logical channel(s) indicated by T1_T4_burst_type parameter of BNCH/T (table A.16) or BSCH-Q/T (table A.17), and after decoding return the contents and error indication (where appropriate) on a TCH/7,2 or TCH-P/10,8 or SCH-Q/U logical channel;
- **speech:** where the TETRA equipment is capable of supporting TCH/S (i.e. it contains a speech codec), it shall be possible to loop back the received speech traffic at the output of the speech decoder, at the 128 kbit/s rate, into the input of the speech encoder, for retransmission to the **test system** on a TCH/S logical channel as required by ETSI EN 300 395-4 [6], clause 7. The channel loop back for TCH/S (at the TMV-SAP) and the speech loop back (at the speech codec digital audio interface) shall be mutually exclusive. Thus speech traffic may be looped back after channel decoding (on a TCH/7,2 logical channel) for BER testing, or after speech decoding (on a TCH/S logical channel) for bit-exact speech codec testing.

D.7.3 Switching for loop back test mode

Figure D.4 shows the functional requirements for loop back T1 and T4 test modes. The actual physical implementation is left open to the manufacturer. The loop back for the speech encoder/decoder can only be selected when the test mode switch 1 is set to normal.

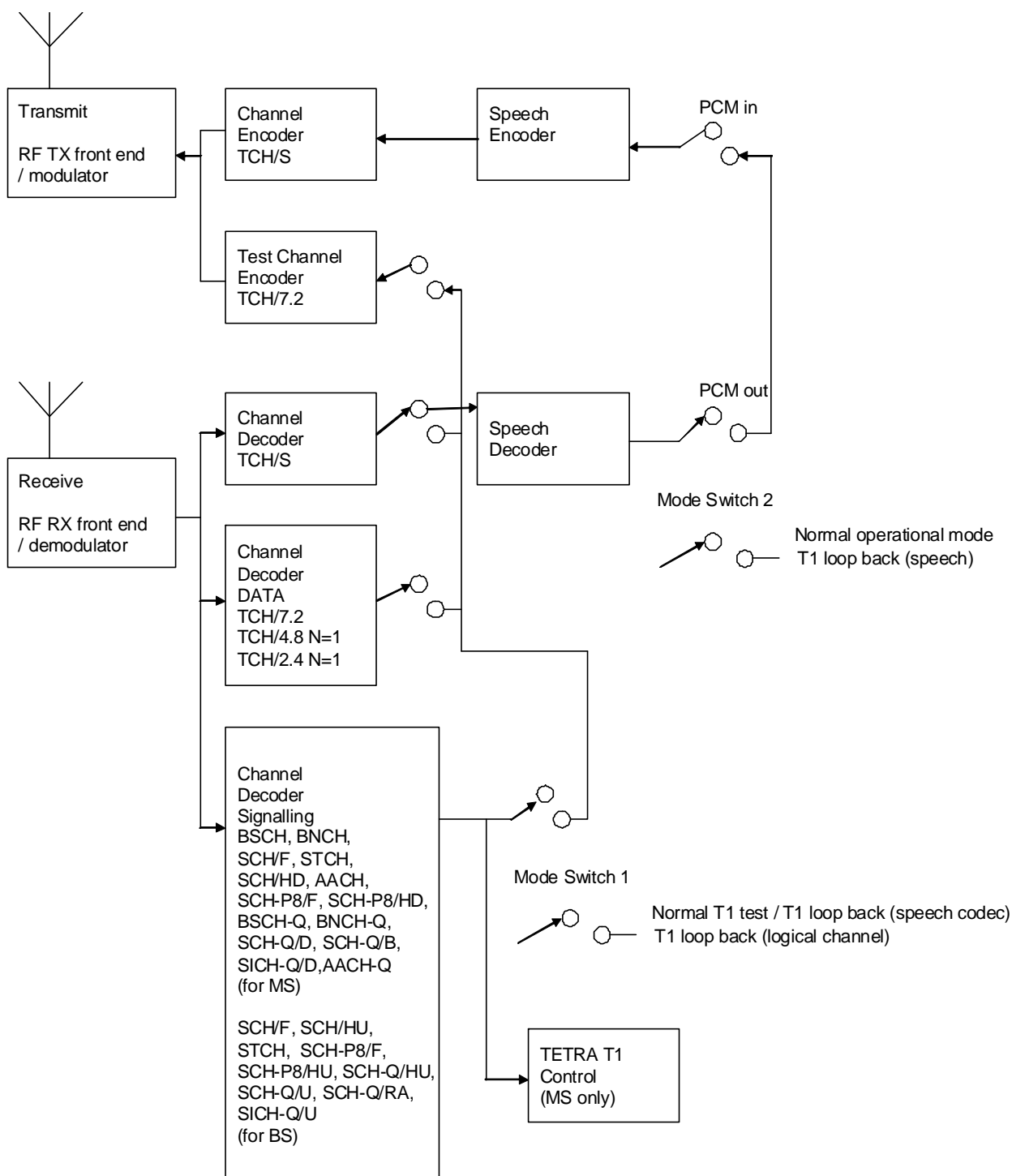

Figure D.4: Functional requirements for MS and BS T1/T4 loop back test mode

D.8 TETRA RF loop back T1 test mode (phase modulation)

D.8.0 Applicability

This clause defines the TETRA RF loop back **T1 test mode**. It does not apply to the TETRA Test (TT) protocol.

D.8.1 Setting TETRA equipment into T1 test mode

Clause 4.1.1 applies.

With the MS or BS equipment in Test Receive Mode or Test Transmit Mode (clause 5.2), **T1 loop back test mode** can be selected which shall configure the TETRA equipment to loop back selected channels to the test system without access to special test connectors. This enables the test system to measure receiver performance of the equipment in terms of Bit Error Rate (BER), Probability of Undetected Erroneous Message (PUEM) and Message Erasure Rate (MER). The TETRA equipment shall return test signals via its air interface.

D.8.2 T1 loop back test mode operation

To operate the MS **T1 loop back test mode** over the air interface, the T1 BNCH/T parameters T1_T4_burst_type and Loop_back (table A.16) shall be used to invoke the "virtual test connector" to provide decoded data output to the **test system** for performing receiver tests using the T1 Test Signal. **T1 loop back test mode** comprises **T1 loopback MS test receive mode** and **T1 loopback MS speech codec test**. When **T1 loopback MS test receive mode** is invoked, the methods described in clause D.8.4 shall apply. T1 Test Mode operation is summarized in table D.15.

Table D.15: T1 BNCH/T parameter control of MS operation

T1 BNCH/T parameters				MS Operation
Loop_back	Tx_on	Tx_burst_type	T1_T4_burst_type	
0	0	Do not care	1, 2, 3, 4, 15, 17, 21, 22, 24	MS test receive mode; decoded data is output on test connector
0	0	Do not care	19	MS speech codec test mode; decoded speech is re-coded as TCH/S and output on test connector
0	1	0	< 21	MS test transmit mode; MS transmits normal uplink bursts containing TCH/7,2 PRBS
0	1	1	< 21	MS test transmit mode; MS transmits control uplink bursts in SSN1 containing SCH/HU PRBS
0	1	0	21, 24	MS test transmit mode; MS transmits normal uplink bursts containing TCH-P8/10,8 PRBS
0	1	1	22	MS test transmit mode; MS transmits control uplink bursts in SSN1 containing SCH-P8/HU PRBS
1	Do not care	Do not care	1, 2, 3, 4, 15, 17	T1 loopback MS test receive mode; decoded data is output on air interface by MS transmitting normal uplink bursts containing TCH/7,2 data
1	Do not care	Do not care	19	T1 loopback MS speech codec test mode; decoded speech is re-coded as TCH/S and transmitted on TCH/S in normal uplink bursts
1	Do not care	Do not care	21, 22, 24	T1 loopback MS test receive mode; decoded data is output on air interface by MS transmitting normal uplink burst containing TCH-P8/10,8 data

To operate the BS **T1 loop back test mode** the BS shall be configured using the method provided by the BS manufacturer.

D.8.3 Logical channels to be looped back

Logical channels to which this loop back mechanism applies are shown in table D.16.

Table D.16: T1 Logical channels testable with RF loop back

T1_T4_burst_type	Logical Channel(s)
Type 1	TCH/7,2 (downlink) + AACH (notes 1 and 2)
Type 2	SCH/F (downlink) + AACH
Type 3	BSCH + SCH/HD (downlink) + AACH (note 1)
Type 4	TCH/2,4 N = 1 (downlink) + AACH
Type 7	TCH/7,2 (uplink)
Type 8	SCH/F (uplink)
Type 9	STCH + STCH (uplink)
Type 10	TCH/2,4 N = 1 (uplink)
Type 11	SCH/HU + SCH/HU
Type 15	TCH/S (downlink) + AACH (note 1)
Type 16	TCH/S (uplink)
Type 17	TCH/4,8 N = 1 (downlink) + AACH (notes 1 and 3)
Type 18	TCH/4,8 N = 1 (uplink) (note 3)
Type 19	TCH/S speech codec test (downlink)
Type 20	TCH/S speech codec test (uplink)
Type 21	TCH-P8/10,8
Type 22	SCH-P8/HD + SCH-P8/HD
Type 23	SCH-P8/HU + SCH-P8/HU
Type 24	SCH-P8/F

NOTE 1: AACH is only tested (annex A) with type 2 and type 4.
 NOTE 2: RF loopback only returns decoded data for TCH/7,2, not for AACH.
 NOTE 3: TCH/4,8 N = 1 is not tested (annex A).

D.8.4 Return channel for logical channel loop back

D.8.4.0 Return data

The received logical channel(s) which are to be looped back are decoded to the MAC block type-1 bits level at the TMV-SAP. The decoded type-1 bits are returned to the **test system** over the air interface as follows:

The channel used to loop back the requested logical channels shall be a TCH/7,2 ($\pi/4$ -DQPSK) or TCH-P8/10,8 ($\pi/8$ -D8PSK). This channel is encoded normally as in ETSI EN 300 392-2 [1], clause 8, that is the bits are only scrambled. In the case of the MS the scrambling code shall be the current extended colour code as defined by the BSCH information generated by the **test system** T1 signal generator. In the case of the BS the scrambling code shall be the current extended colour code as defined by the BSCH information generated by the BS.

The TCH/7,2 or TCH-P8/10,8 data is contained in Normal Uplink Bursts (for the MS) or Normal Downlink Bursts (for the BS) transmitted in FN 1 to FN 17 in TN 1 only. In the case of the BS, the AACH data in the BBK of these bursts is undefined.

The general method of assembling the return data is shown in figure D.5.

Full slot or 1 st subslot or 1 st block information	Fill	2 nd subslot or 2 nd block information if applicable	Fill	AACH MS only	E3	E2	E1
---	------	--	------	--------------	----	----	----

Figure D.5: General structure of returned signalling information

The E1,E2 and E3 fields are single bit indications of an error state detected by the receiver on test (e.g. parity check wrong). The bit is set to 1 to indicate an error and 0 for no error detected or not applicable:

- E1 applies to the full slot or SS1/BKN1 information;

- E2 applies to SS2/BKN2 information when applicable;
- E3 applies to the AACH logical channel information.

The use of the 432 input bits to the channel is defined in individual clauses D.8.4.1 to D.8.4.13. The notation used for the bits is that used in ETSI EN 300 392-2 [1], clause 8. When no burst has been received where one was expected, the returned bits shall be set to all zeroes, except for the error bits which shall be set to ones.

D.8.4.1 Type 1: TCH/7,2 + AACH

When the T1 BNCH/T information requests a downlink Type 1 channel to be looped back, the received channel in BKN1 and BKN2 is unscrambled. The resultant 432 bits received ($b_1(1), b_1(2), \dots, b_1(432)$) are included in a TCH/7,2 block as shown in figure D.6. The received AACH in BBK, which is 14 bits after error decoding ($b_1(1), b_1(2), \dots, b_1(14)$), is unable to be included with the looped back information in this case, and is discarded. The order of the bits is shown in figure D.6 - note that this does not follow the general method shown in figure D.5 as there is no AACH data and there are no E1 / E2 / E3 bits.

432 bits of TCH/7,2 logical channel from BKN1 and BKN2

Figure D.6: Returned data for Type 1: TCH/7,2 + AACH

D.8.4.2 Type 2: SCH/F + AACH

When the T1 BNCH/T information requests a downlink Type 2 channel to be looped back, the received channel in BKN1 and BKN2 is unscrambled, de-interleaved, decoded and parity checked. The resultant 268 bits received ($b_1(1), b_1(2), \dots, b_1(268)$) are included in a TCH/7,2 block as shown in figure D.7. The received AACH in BBK, which is 14 bits after error decoding ($b_1(1), b_1(2), \dots, b_1(14)$), is included with the looped back information along with any error indications in E1 and E3. Fill bits and error bit E2 are set to zero. The order of the bits is shown in figure D.7.

268 bits of SCH/F logical channel	Fill 147 bits	AACH 14 bits	E3 1 bit	E2 1 bit	E1 1 bit
--	--------------------------	-------------------------	---------------------	---------------------	---------------------

Figure D.7: Returned data for SCH/F + AACH

D.8.4.3 Type 3: BSCH + SCH/HD + AACH

When the T1 BNCH/T information requests a downlink Type 3 channel to be looped back, the BSCH channel in the first block of the Synchronization Burst is unscrambled, de-interleaved, decoded and parity checked. The resultant 60 bits received ($b_1(1), b_1(2), \dots, b_1(60)$) are included in a TCH/7,2 block as shown in figure D.8. The SCH/HD contained in BKN2 is decoded and the 124 bits ($b_1(1), b_1(2), \dots, b_1(124)$) are also returned. The received AACH in BBK, which is 14 bits after error decoding ($b_1(1), b_1(2), \dots, b_1(14)$), is included with the looped back information along with any error indications in E1, E2 and E3. Fill bits are set to zero. The return TCH/7,2 channel shall be scrambled using the existing extended colour code, i.e. the PRBS content of the BSCH shall not be interpreted as new values of MCC / MNC / BCC. The order of the bits is shown in figure D.8.

60 bits BSCH logical channel	Fill 156 bits	SCH/HD logical channel 124 bits	Fill 75 bits	AACH 14 bits	E3 1 bit	E2 1 bit	E1 1 bit
-------------------------------------	----------------------	--	-------------------------	-------------------------	---------------------	---------------------	---------------------

Figure D.8: Returned data for BSCH + SCH/HD + AACH

D.8.4.4 Type 4: TCH/2,4 N = 1 + AACH

When the T1 BNCH/T information requests a downlink Type 4 channel to be looped back, the received channel in BKN1 and BKN2 is unscrambled, de-interleaved and decoded. The resultant 144 bits received ($b_1(1), b_1(2), \dots, b_1(144)$) are included in a TCH/7,2 block as shown in figure D.9. The received AACH in BBK, which is 14 bits after error decoding ($b_1(1), b_1(2), \dots, b_1(14)$), is included with the looped back information along with any error indication in E3. Fill bits and error bits E1 and E2 are set to zero. The order of the bits is shown in figure D.9.

144 bits of TCH/2,4 N=1 logical channel	Fill 271 bits	AACH 14 bits	E3 1 bit	E2 1 bit	E1 1 bit
--	--------------------------	-------------------------	---------------------	---------------------	---------------------

Figure D.9: Returned data for Type 4: TCH/2,4 N = 1 + AACH

D.8.4.5 Type 7: TCH/7,2 (uplink)

When the BS configuration requests an uplink Type 7 channel to be looped back, the received channel in BKN1 and BKN2 is unscrambled. The resultant 432 bits received ($b_1(1), b_1(2), \dots, b_1(432)$) are included in a TCH/7,2 block as shown in figure D.10. The order of the bits is shown in figure D.10 - note that this does not follow the general method shown in figure D.5 as there are no E1 / E2 / E3 bits.

432 bits of TCH/7,2 logical channel from BKN1 and BKN2

Figure D.10: Returned data for Type 7: TCH/7,2 (uplink)

D.8.4.6 Type 8: SCH/F (uplink)

When the BS configuration requests an uplink Type 8 channel to be looped back, the received channel in BKN1 and BKN2 is unscrambled, de-interleaved, decoded and parity checked. The resultant 268 bits received ($b_1(1), b_1(2), \dots, b_1(268)$) are included in a TCH/7,2 block as shown in figure D.11, along with any error indication in E1. Fill bits and error bits E2 and E3 are set to zero. The order of the bits is shown in figure D.11.

268 bits of SCH/F logical channel	Fill 161 bits	E3 1 bit	E2 1 bit	E1 1 bit
--	--------------------------	---------------------	---------------------	---------------------

Figure D.11: Returned data for SCH/F (uplink)

D.8.4.7 Type 9: STCH + STCH (uplink)

When the BS configuration requests an uplink Type 9 channel to be looped back, the received channel in BKN1 is unscrambled, de-interleaved, decoded and parity checked. The resultant 124 bits received ($b_1(1), b_1(2), \dots, b_1(124)$) are included in a TCH/7,2 block as shown in figure D.12. BKN2 is also decoded as STCH and included in the TCH/7,2 block, along with any error indications in E1 and E2. The fill bits and error bit E3 are set to zero. The order of the bits is shown in figure D.12.

124 bits of STCH logical channel	92 bits	124 bits from STCH logical channel from BKN2	Fill 89 bits	E3 1 bit	E2 1 bit	E1 1 bit
Fill from BKN1						

Figure D.12: Returned data for STCH + STCH (uplink)

D.8.4.8 Type 10: TCH/2,4 N = 1 (uplink)

When the BS configuration requests an uplink Type 10 channel to be looped back, the received channel in BKN1 and BKN2 is unscrambled, de-interleaved and decoded. The resultant 144 bits received ($b_1(1), b_1(2), \dots, b_1(144)$) are included in a TCH/7,2 block as shown in figure D.13. Fill bits and error bits are set to zero. The order of the bits is shown in figure D.13.

144 bits of TCH/2.4 N=1 logical channel	Fill 285 bits	E3 1 bit	E2 1 bit	E1 1 bit
--	--------------------------	---------------------	---------------------	---------------------

Figure D.13: Returned data for Type 10: TCH/2,4 N = 1 + AACH

D.8.4.9 Type 11: SCH/HU + SCH/HU

When the BS configuration requests an uplink Type 11 channel to be looped back, then, if present, the received channel in SS1 is unscrambled, de-interleaved, decoded and parity checked. The resultant 92 bits received ($b_1(1), b_1(2), \dots, b_1(92)$) are included in a TCH/7,2 block as shown in figure D.14, along with any error indication in E1. If the second half of the received slot SS2 contains a SCH/HU the decoded 92 bits ($b_1(1), b_1(2), \dots, b_1(92)$) are returned, along with any error indication in E2. Fill bits and error bit E3 are set to zero. The order of the bits is shown in figure D.14.

92 bits from SCH/HU logical channel in subslot 11	Fill 124 bits	92 bits from SCH/HU logical channel in subslot 2	Fill 121 bits	E3 1 bit	E2 1 bit	E1 1 bit
--	--------------------------	---	--------------------------	---------------------	---------------------	---------------------

Figure D.14: Returned data for SCH/HU + SCH/HU

D.8.4.10 Type 15: TCH/S + TCH/S + AACH

When the T1 BNCH/T information requests a downlink Type 15 channel to be looped back, the received channel in BKN1 and BKN2 is unscrambled, de-interleaved and decoded. The resultant 2×137 bits received ($b_1(1), b_1(2), \dots, b_1(137)$) are included in a TCH/7,2 block as shown in figure D.15. The received AACH in BBK, which is 14 bits after error decoding ($b_1(1), b_1(2), \dots, b_1(14)$), is included with the looped back information along with any error indications in E1 and E3. Fill bits and error bit E2 are set to zero. The order of the bits is shown in figure D.15.

TCH/S logical channel 137 bits Speech Sample A	Fill 79 bits	TCH/S logical channel 137 bits Speech Sample B	Fill 62 bits	AACH 14 bits	E3 1 bit	E2 1 bit	E1 1 bit
---	-------------------------	---	-------------------------	-------------------------	---------------------	---------------------	---------------------

Figure D.15: Returned data for TCH/S + TCH/S + AACH

D.8.4.11 Type 16: TCH/S + TCH/S (uplink)

When the BS configuration requests an uplink Type 16 channel to be looped back, the received channel in BKN1 and BKN2 is unscrambled, de-interleaved and decoded. The resultant 2×137 bits received ($b_1(1), b_1(2), \dots, b_1(137)$) are included in a TCH/7,2 block as shown in figure D.16, along with any error indication in E1. Fill bits and error bits E2 and E3 are set to zero. The order of the bits is shown in figure D.16.

TCH/S logical channel 137 bits Speech Sample A	Fill 79 bits	TCH/S logical channel 137 bits Speech Sample B	Fill 76 bits	E3 1 bit	E2 1 bit	E1 1 bit
---	-------------------------	---	-------------------------	---------------------	---------------------	---------------------

Figure D.16: Returned data for TCH/S + TCH/S (uplink)

D.8.4.12 Type 17: TCH/4,8 N = 1 + AACH

When the T1 BNCH/T information requests a downlink Type 17 channel to be looped back, the received channel in BKN1 and BKN2 is unscrambled, de-interleaved and decoded. The resultant 288 bits received ($b_1(1), b_1(2), \dots, b_1(288)$) are included in a TCH/7,2 block as shown in figure D.17. The received AACH in BBK, which is 14 bits after error decoding ($b_1(1), b_1(2), \dots, b_1(14)$), is included with the looped back information along with any error indication in E3. Fill bits and error bits E1 and E2 are set to zero. The order of the bits is shown in figure D.17.

288 bits of TCH/4.8 N=1 logical channel	Fill 127 bits	AACH 14 bits	E3 1 bit	E2 1 bit	E1 1 bit
--	--------------------------	-------------------------	---------------------	---------------------	---------------------

Figure D.17: Returned data for Type 17: TCH/4,8 N = 1 + AACH

D.8.4.13 Type 18: TCH/4,8 N = 1 (uplink)

When the BS configuration requests an uplink Type 18 channel to be looped back, the received channel in BKN1 and BKN2 is unscrambled, de-interleaved and decoded. The resultant 288 bits received ($b_1(1), b_1(2), \dots, b_1(288)$) are included in a TCH/7,2 block as shown in figure D.18. Fill bits and error bits are set to zero. The order of the bits is shown in figure D.18.

288 bits of TCH/4.8 N=1 logical channel	Fill 141 bits	E3 1 bit	E2 1 bit	E1 1 bit
--	--------------------------	---------------------	---------------------	---------------------

Figure D.18: Returned data for Type 18: TCH/4,8 N = 1 (uplink)

D.8.4.14 Type 19: TCH/S speech codec test (downlink)

This T1 type is intended for performing bit-exact speech codec tests. When the T1 BNCH/T information requests a downlink Type 19 channel to be looped back, the received channel in BKN1 and BKN2 is unscrambled, de-interleaved and decoded. The resultant 2×137 bits received ($b_1(1), b_1(2), \dots, b_1(137)$) are decoded by the speech codec as 60 ms of speech in the form of 480×16 -bit linear PCM samples. These PCM samples are re-encoded by the speech codec to form 2×137 bits ($b_1(1), b_1(2), \dots, b_1(137)$) which are coded, interleaved, scrambled and included in a TCH/7,2 block as shown in figure D.19. The received AACH in BBK is discarded. The order of the bits is shown in figure D.19.

432 bits of TCH/S logical channel from BKN1 and BKN2, decoded and re-encoded by speech and channel codec

Figure D.19: Returned data for Type 19: TCH/S speech codec test (downlink)

D.8.4.15 Type 20: TCH/S speech codec test (uplink)

This T1 type is only applicable to a BS which includes a speech codec, or which is connected to a speech codec for testing purposes. When the BS configuration requests an uplink type 20 channel to be looped back, the received channel in BKN1 and BKN2 is unscrambled, de-interleaved and decoded. The resultant 2×137 bits received ($b_1(1), b_1(2), \dots, b_1(137)$) are decoded by the speech codec as 60 ms of speech in the form of 480×16 -bit linear PCM samples. These PCM samples are re-encoded by the speech codec to form 2×137 bits ($b_1(1), b_1(2), \dots, b_1(137)$) which are coded, interleaved, scrambled and included in a TCH/7,2 block as shown in figure D.20. The order of the bits is shown in figure D.20.

432 bits of TCH/S logical channel from BKN1 and BKN2, decoded and re-encoded by speech and channel codec

Figure D.20: Returned data for Type 20: TCH/S speech codec test (uplink)

D.8.4.16 Type 21: TCH-P8/10,8 (downlink)

When the T1 BNCH/T information requests a downlink Type 21 channel to be looped back, the received channel in BKN1 and BKN2 is unscrambled. The resultant 648 bits received ($b_1(1), b_1(2), \dots, b_1(648)$) are included in a TCH-P8/10,8 block as shown in figure D.21. The received AACH in BBK, which is 14 bits after error decoding ($b_1(1), b_1(2), \dots, b_1(14)$), is unable to be included with the looped back information in this case, and is discarded. The order of the bits is shown in figure D.21 - note that this does not follow the general method shown in figure D.5 as there is no AACH data and there are no E1 / E2 / E3 bits.

648 bits of TCH-P8/10,8 logical channel from BKN1 and BKN2

Figure D.21: Returned data for Type 21: TCH-P8/10,8

D.8.4.17 Type 22: SCH-P8/HD + SCH-P8/HD

When the BS configuration requests an uplink Type 22 channel to be looped back, then, if present, the received channel in SS1 is unscrambled, de-interleaved, decoded and parity checked. The resultant 196 bits received ($b_1(1), b_1(2), \dots, b_1(196)$) are included in a TCH-P8/10,8 block as shown in figure D.22, along with any error indication in E1. If the second half of the received slot SS2 contains a SCH-P8/HD the decoded 196 bits ($b_1(1), b_1(2), \dots, b_1(196)$) are returned, along with any error indication in E2. Fill bits and error bit E3 are set to zero. The order of the bits is shown in figure D.22.

196 bits from SCH-P8/HD logical channel subslot 1	Fill 128 bits	196 bits from SCH-P8/HD logical channel subslot 2	Fill 125 bits	E3 1 bit	E2 1 bit	E1 1 bit
--	--------------------------	--	--------------------------	---------------------	---------------------	---------------------

Figure D.22: Returned data for SCH-P8/HU + SCH-P8/HU

D.8.4.18 Type 24: SCH-P8/F (downlink)

When the T1 BNCH/T information requests a downlink Type 24 channel to be looped back, the received channel in BKN1 and BKN2 is unscrambled, de-interleaved, decoded and parity checked. The resultant 412 bits received ($b_1(1), b_1(2), \dots, b_1(412)$) are included in a TCH P8/10,8 block as shown in figure D.23. The received AACH in BBK, which is 14 bits after error decoding ($b_1(1), b_1(2), \dots, b_1(14)$), is included with the looped back information along with any error indications in E1 and E3. Fill bits and error bit E2 are set to zero. The order of the bits is shown in figure D.23.

412 bits of SCH-P8/F logical channel	Fill 219 bits	AACH 14 bits	E3 1 bit	E2 1 bit	E1 1 bit
---	--------------------------	-------------------------	---------------------	---------------------	---------------------

Figure D.23: Returned data for SCH-P8/F + AACH

D.8.4.19 Type 21: TCH-P8/10,8 (uplink)

When the BS configuration requests an uplink Type 21 channel to be looped back, the received channel in BKN1 and BKN2 is unscrambled. The resultant 648 bits received ($b_1(1), b_1(2), \dots, b_1(648)$) are included in a TCH-P8/10,8 block as shown in figure D.24. The order of the bits is shown in figure D.24 - note that this does not follow the general method shown in figure D.5 as there are no E1 / E2 / E3 bits.

648 bits of TCH-P8/10,8 logical channel from BKN1 and BKN2

Figure D.24: Returned data for Type 21: TCH-P8/10,8 (uplink)

D.8.4.20 Type 24: SCH-P8/F (uplink)

When the BS configuration requests an uplink Type 24 channel to be looped back, the received channel in BKN1 and BKN2 is unscrambled, de-interleaved, decoded and parity checked. The resultant 412 bits received ($b_1(1), b_1(2), \dots, b_1(412)$) are included in a TCH-P8/10,8 block as shown in figure D.25, along with any error indication in E1. Fill bits and error bits E2 and E3 are set to zero. The order of the bits is shown in figure D.25.

412 bits of SCH-P8/F logical channel	Fill 233 bits	E3 1 bit	E2 1 bit	E1 1 bit
---	--------------------------	---------------------	---------------------	---------------------

Figure D.25: Returned data for SCH-P8/F (uplink)

D.8.4.21 Type 23: SCH-P8/HU + SCH-P8/HU

When the BS configuration requests an uplink Type 23 channel to be looped back, then, if present, the received channel in SS1 is unscrambled, de-interleaved, decoded and parity checked. The resultant 148 bits received ($b_1(1), b_1(2), \dots, b_1(148)$) are included in a TCH-P8/10,8 block as shown in figure D.26, along with any error indication in E1. If the second half of the received slot SS2 contains a SCH/HU the decoded 148 bits ($b_1(1), b_1(2), \dots, b_1(148)$) are returned, along with any error indication in E2. Fill bits and error bit E3 are set to zero. The order of the bits is shown in figure D.26.

148 bits from SCH-P8/HU logical channel subslot 1	Fill 176 bits	148 bits from SCH-P8/HU logical channel subslot 2	Fill 173 bits	E3 1 bit	E2 1 bit	E1 1 bit
--	--------------------------	--	--------------------------	---------------------	---------------------	---------------------

Figure D.26: Returned data for SCH-P8/HU + SCH-P8/HU

D.8.5 Loop back test scenarios

Tables D.17 and D.18 summarize the expected use of the T1 loop back facility. Table D.17 shows the scenarios for testing a TETRA MS when the TSS is generating a downlink T1 signal. Table D.18 shows the scenarios for testing a TETRA BS when the BS is generating a downlink T1 signal and the TSS is generating an uplink T1 signal synchronized to the BS.

Table D.17: MS T1 loop back testing

MS testing Loop back channel(s)	TSS configured as a downlink T1 signal generator			
	Test signal	Mobile receives	Mobile transmits	General setting of TSS
TCH/x + AACH	T1 type 1, 4, 15 or 17 on the required RF channel.	TN1 frames 1 to 17 decoded as TCH/x + AACH to MAC blocks at TMV-SAP.	Formats received logical channels and errors as defined in clause D.8.4 and transmits as TCH/7,2 on TN1 frames 1 to 17.	T1 signal as defined in clause 5.3.2.
SCH/F + AACH	T1 type 2 on the required RF channel.	TN1 frames 1 to 17 decoded as SCH/F + AACH to MAC blocks at TMV-SAP.	There may be a constant delay between reception and retransmission, as well as allowance for frame 18.	T1 signal as defined in clause 5.3.2.
BSCH + SCH/HD + AACH	T1 type 3 on the required RF channel.	TN1 frames 1 to 17 decoded as BSCH + SCH/HD + AACH to MAC blocks at TMV-SAP.		T1 signal as defined in clause 5.3.2.
Speech codec bit-exact test.	T1 type 19 on the required RF channel containing TCH/S codec test vectors.	TN1 frames 1 to 17 decoded as TCH/S to 128 kbit/s PCM at speech decoder output.	Encodes received 128 kbit/s at speech encoder input and transmits as a TCH/S. There may be a constant (and frame 18) delay before retransmission.	T1 signal type 19, containing codec test vectors instead of PRBS.
TCH-P8/10,8 + AACH	T1 type 21 on the required RF channel.	TN1 frames 1 to 17 decoded as TCH-P8/10,8 + AACH to MAC blocks at TMV-SAP.	The MS formats received logical channels and errors as defined in clause D.8.4 and transmits as TCH-P8/10,8 on TN1 frames 1 to 17. There may be a constant delay between reception and retransmission, as well as allowance for frame 18.	T1 signal as defined in clause 5.3.2.
SCH-P8/F + AACH	T1 type 24 on the required RF channel.	TN1 frames 1 to 17 decoded as SCH-P8/F + AACH to MAC blocks at TMV-SAP.		
SCH-P8/HD + SCH-P8/HD	T1 type 22 on the required RF channel.	TN1 frames 1 to 17 decoded as SCH-P8/HD + SCH-P8/HD to MAC blocks at TMV-SAP.		

Table D.18: BS T1 loop back testing

BS testing Loop back channel(s)	TSS configured as uplink T1 signal generator, synchronized to BS			
	Test signal	BS receives	BS transmits	General setting of TSS
TCH/x	T1 type 7, 10, 16 or 18 on uplink RF channel.	TN1 frames 1 to 17 decoded as TCH/x to MAC blocks at TMV-SAP.	Formats received logical channel and errors as defined in clause D.8.4 and transmits as TCH/7,2 on TN1 frames 1 to 17.	Uplink T1 signal synchronized to downlink T1 signal generated by BS under test.
SCH/F	T1 type 8 on uplink RF channel	TN1 frames 1 to 17 decoded as SCH/F to MAC blocks at TMV-SAP.	There may be a constant delay between reception and retransmission, as well as allowance for frame 18.	Uplink T1 signal synchronized to downlink T1 signal generated by BS under test.
STCH + STCH	T1 type 9 on uplink RF channel.	TN1 frames 1 to 17 decoded as STCH + STCH to MAC blocks at TMV-SAP.		Uplink T1 signal synchronized to downlink T1 signal generated by BS under test.
SCH/HU + SCH/HU	T1 type 11 on uplink RF channel.	TN1 frames 1 to 17 decoded as SCH/HU + SCH/HU to MAC blocks at TMV-SAP.		Uplink T1 signal synchronized to downlink T1 signal generated by BS under test.
BS Speech codec bit-exact test (requires codec in BS or attached to it).	T1 type 20 on uplink RF channel containing TCH/S codec test vectors.	TN1 frames 1 to 17 decoded as TCH/S to 128 kbit/s PCM at speech decoder output.	Encodes received 128 kbit/s at speech encoder input and transmits as a TCH/S. There may be a constant (and frame 18) delay before retransmission.	T1 signal type 20, containing codec test vectors instead of PRBS.
TCH-P8/10,8	T1 type 21 on uplink RF channel.	TN1 frames 1 to 17 decoded as TCH-P8/10,8 to MAC blocks at TMV-SAP.	The MS formats received logical channels and errors as defined in clause D.8.4 and transmits as TCH-P8/10,8 on TN1 frames 1 to 17.	Uplink T1 signal synchronized to downlink T1 signal generated by BS under test.
SCH-P8/F	T1 type 24 on uplink RF channel.	TN1 frames 1 to 17 decoded as SCH-P8/F to MAC blocks at TMV-SAP.	There may be a constant delay between reception and retransmission, as well as allowance for frame 18.	Uplink T1 signal synchronized to downlink T1 signal generated by BS under test.
SCH-P8/HU + SCH-P8/HU	T1 type 23 on uplink RF channel.	TN1 frames 1 to 17 decoded as SCH-P8/HU + SCH-P8/HU to MAC blocks at TMV-SAP.		Uplink T1 signal synchronized to downlink T1 signal generated by BS under test.

D.9 TETRA RF loop back T4 test mode (QAM)

D.9.0 Applicability

This clause defines the TETRA RF loop back T4 test mode. It does not apply to the TETRA Test (TT) protocol.

D.9.1 Setting TETRA equipment into T4 test mode

Clause 4.1.1 applies.

With the MS or BS equipment in Test Receive Mode or Test Transmit Mode (clause 5.2), **T4 loop back test mode** can be selected which shall configure the TETRA equipment to loop back selected channels to the test system without access to special test connectors. This enables the test system to measure receiver performance of the equipment in terms of Bit Error Rate (BER), Probability of Undetected Erroneous Message (PUEM) and Frame Erasure Rate (FER). The TETRA equipment shall return test signals via its air interface.

NOTE: A residual bit error rate, that may be present in the transmitter, should be taken into account when using loopback to measure receiver bit error rate. The receiver bit error rate will always be a combination of the bit errors in the receiver plus the bit errors in the transmitter.

D.9.2 T4 loop back test mode operation

To operate the MS **T4 loop back test mode** over the air interface, the T4 BNCH/T (table A.16) and BSCH-Q/T (table A.17) parameters T1_T4_burst_type and Loop_back shall be used to invoke the "virtual test connector" to provide decoded data output to the **test system** for performing receiver tests using the T4 Test Signal. **T4 loop back test mode** comprises **T4 loopback MS test receive mode**. When **T4 loopback MS test receive mode** is invoked, the methods described in clause D.9.4 shall apply. T4 Test Mode operation is summarized in table D.19.

Table D.19: T4 BNCH/T and BSCH-Q/T parameter control of MS operation

Loop_back	Tx_on	Tx_burst_type	Error correction	T1_T4_burst_type	
0	0	Do not care	Do not care	27	MS test receive mode; decoded data is output on test connector.
0	1	0	Do not care	Do not care	MS test transmit mode; MS transmits normal uplink bursts containing SCH-Q/U PRBS.
0	1	1	Do not care	Do not care	MS test transmit mode; MS transmits control uplink bursts in SSN1 containing SCH-Q/HU PRBS.
1	Do not care	Do not care	0	27	T4 loopback MS test receive mode; decoded data is output on air interface by MS transmitting normal uplink bursts using SCH-Q/U data. The received data is error corrected before loopback. This mode can be used for FER tests.
1	Do not care	Do not care	1	27	T4 loopback MS test receive mode; decoded data is output on air interface by MS transmitting normal uplink bursts using SCH-Q/U data. The received data is not error corrected before loopback. This mode can be used for BER tests.

To operate the BS **T4 loop back test mode** the BS shall be configured using the method provided by the BS manufacturer.

D.9.3 Logical channels to be looped back

Logical channels to which this loop back mechanism applies are shown in table D.20.

Table D.20: T4 Logical channels testable with RF loop back

T1_T4_burst_type	Logical Channel(s)
Type 25	SCH-Q/HU
Type 26	SCH-Q/U
Type 27	SCH-Q/D (note)
Type 28	SCH-Q/RA
NOTE: The SCH-Q/D is looped back on the SCH-Q/U logical channel, which having fewer bits, cannot loop all of the data back for BER testing, see clause D.9.4.2.	

D.9.4 Return channel for logical channel loop back

D.9.4.0 Return data

The received logical channel(s) which are to be looped back are decoded to the MAC block type-1 bits level at the TMV- SAP. The decoded type-1 bits are returned to the **test system** over the air interface as follows:

The channel used to loop back the requested logical channels shall be a SCH-Q/U or SCH-Q/D. This channel contains K_4 type-4 bits and they are only scrambled as per ETSI EN 300 392-2 [1], clauses 8.3.2.5 and 8.3.2.6 i.e. only scrambling of type-4 bits into type-5 bits is applicable, excluding the encoding and interleaving of type-1 bits into type-4 bits. In the case of the MS the scrambling code shall be the current extended colour code as defined by the BSCH or BSCH-Q/T information generated by the **test system** T4 signal generator. In the case of the BS the scrambling code shall be the current extended colour code as defined by the BSCH or BNCH-Q/T information generated by the BS.

The looped back data is contained in Normal Uplink Bursts (SCH-Q/U for the MS) or Normal Downlink Bursts (SCH-Q/D for the BS) transmitted in $FN1$ to $FN17$ in $TN1$ only. The width of the data varies based on the number of sub-carriers and the modulation level. The loopback channel bandwidth and modulation level is always the same as the TSS.

The general method of assembling the return data is shown in figure D.27.

Full slot or 1st sub-slot of burst	Fill bits	2 nd sub-slots if applicable	Fill bits	SICH-Q/U or SICH-Q/D + ACCH-Q encoded with RM code	0, E4, E3, E2, E1 encoded with (16,5)RM code
------------------------------------	-----------	---	-----------	--	--

Figure D.27: General structure of returned signalling information

The E1, E2, E3 and E4 fields are single bit indications of an error state detected by the receiver on test (e.g. parity check wrong). The bit is set to 1 to indicate an error and 0 for no error detected or not applicable:

- E1 applies to the full slot or $SSN1$ information;
- E2 applies to $SSN2$ information when applicable;
- E3 applies to the AACH-Q logical channel information;
- E4 applies to the SICH-Q logical channel information.

These four bits plus a leading zero are error encoded with the (16,5) RM code, as described in ETSI EN 300 392-2 [1], clause 8.

The SICH-Q/U bits, when looped back from the uplink, are protected with the (16,5) RM code also. This is the same coding scheme used to protect these bits when they are transmitted on the uplink. Likewise, the SICH-Q/D + AACH-Q bits from the downlink are error encoded when looped back.

The use of the input bits to the channel is defined in individual clauses D.9.4.1 to D.9.4.13. The notation used for the bits is that used in ETSI EN 300 392-2 [1], clause 8. When no burst has been received where one was expected, the returned bits shall be set to all zeroes, except for the error bits which shall be set to ones.

D.9.4.1 Type 27: SCH-Q/D with coding rates of 1/2 or 2/3 and error correction enabled

When the T4 BNCH/T or BSCH-Q/T information requests a downlink Type 27 channel to be looped back, if the QAM_payload_type bits indicate the coding rate is 1/2 or 2/3, and the error correction bit in the BNCH/T or BSCH-Q/T is 0, then the received channel is unscrambled, de-interleaved, decoded and parity checked. The resultant K_1 type-1 bits received ($b_1(1), b_1(2), \dots, b_1(K_1)$) are included in a SCH-Q/U block as shown in figure D.28. The received 5 type-1 SICH-Q/D bits are RM encoded as 16 type-2 bits, as in ETSI EN 300 392-2 [1], clause 8.3.2.2, but only as far as the production of the type-2 bits. The received 3x5 type-1 AACH-Q bits are RM encoded as 48 type-2 bits, as in ETSI EN 300 392-2 [1], clause 8.3.2.3, but only as far as the production of the type-2 bits. Fill bits are set to zero. The error bit E2 is set to zero, then the leading 0 and 4 error bits are RM encoded as 16 type-2 bits, as in ETSI EN 300 392-2 [1], clause 8.3.2.2, but only as far as the production of the type-2 bits. All 80 RM encoded bits (16 SICH-Q/D, 48 AACH-Q and 16 error bits) are added after the fill bits and looped back. The order of the bits is shown in figure D.28. Table D.21 shows the value of K_1 and N for each of the channel bandwidth, modulation types and coding rates.

Table D.21: Value of K_1 and N for the return data

Bandwidth	Slotinfo	K_1	N
25 kHz	4-QAM rate = 1/2	185	135
25 kHz	16-QAM rate = 1/2	389	331
25 kHz	64-QAM rate = 1/2	593	527
25 kHz	64-QAM rate = 2/3	797	323
50 kHz	4-QAM rate = 1/2	421	315
50 kHz	16-QAM rate = 1/2	861	691
50 kHz	64-QAM rate = 1/2	1 301	1 067
50 kHz	64-QAM rate = 2/3	1 741	627
100 kHz	4-QAM rate = 1/2	893	675
100 kHz	16-QAM rate = 1/2	1 805	1 411
100 kHz	64-QAM rate = 1/2	2 717	2 147
100 kHz	64-QAM rate = 2/3	3 629	1 235
150 kHz	4-QAM rate = 1/2	1 365	1 035
150 kHz	16-QAM rate = 1/2	2 749	2 131
150 kHz	64-QAM rate = 1/2	4 133	3 227
150 kHz	64-QAM rate = 2/3	5 517	1 843

K_1 type-1 bits of the SCH-Q/D logical channel	N Fill bits	SICH-Q/D error encoded into 16 bits	AACH-Q error encoded into 48 bits	Error bits E4-E1 along with a leading zero encoded into 16 bits

Figure D.28: Returned data for Type 27: SCH-Q/D

D.9.4.2 Type 27: SCH-Q/D with error correction disabled or when the coding rate is 1

When the T4 BNCH/T or BSCH-Q/T information requests a downlink Type 27 channel to be looped back and the error correction bit is 1, the received channel is only unscrambled, no error correction is done. The resultant K_4 type-4 bits received ($b_4(1), b_4(2), \dots, b_4(K_4)$) are truncated to K'_4 type-4 bits ($b_4(1), b_4(2), \dots, b_4(K'_4)$) and these K'_4 type-4 bits are included in a SCH-Q/U block as shown in figure D.29. The received AACH-Q, which is 15 bits after error decoding as well as the SICH-Q which is 5 bits are not included with the looped back information. The order of the bits is shown in figure D.29. Table D.22 shows the value of K'_4 for each of the channel bandwidth and modulation types.

Table D.22: Value of K'_4 for the return data

Bandwidth	Slotinfo	K'_4 (see note)
25 kHz	4-QAM	400
25 kHz	16-QAM	800
25 kHz	64-QAM	1 200
50 kHz	4-QAM	816
50 kHz	16-QAM	1 632
50 kHz	64-QAM	2 448
100 kHz	4-QAM	1 648
100 kHz	16-QAM	3 296
100 kHz	64-QAM	4 944
150 kHz	4-QAM	2 480
150 kHz	16-QAM	4 960
150 kHz	64-QAM	7 440

NOTE: Only the number of bits indicated can be looped back because of the maximum number of bits in a QAM uplink burst.

K'_4 type-4 bits of the SCH-Q/D logical channel

Figure D.29: Returned data for Type 27: SCH-Q/D

D.9.4.3 Type 26: SCH-Q/U with coding rates of 1/2 or 2/3 and error correction enabled

When the BS configuration requests an uplink Type 26 channel to be looped back, if the SICH-Q field indicates the coding rate is 1/2 or 2/3, and the error correction bit is 0, then the received channel is unscrambled, de-interleaved, decoded and parity checked. The resultant K bits received ($b_1(1), b_1(2), \dots, b_1(K)$) are included in a SCH-Q/D block as shown in figure D.30 as well as the error indication in E1. The received SICH-Q, which is 5 bits after error decoding ($b_1(1), b_1(2), \dots, b_1(5)$), is included with the SICH-Q error indications in E4. Fill bits and error bit E2 and E3 are set to zero. The order of the bits is shown in figure D.30. Table D.23 shows the value of K and N for each of the channel bandwidth, modulation types and coding rates.

Table D.23: Value of K and N for each of the channel bandwidth and Slotinfo

Bandwidth	Slotinfo	K	N
25 kHz	4-QAM rate = 1/2	181	195
25 kHz	16-QAM rate = 1/2	381	403
25 kHz	64-QAM rate = 1/2	581	611
25 kHz	64-QAM rate = 2/3	781	411
50 kHz	4-QAM rate = 1/2	389	459
50 kHz	16-QAM rate = 1/2	797	931
50 kHz	64-QAM rate = 1/2	1 205	1 403
50 kHz	64-QAM rate = 2/3	1 613	995
100 kHz	4-QAM rate = 1/2	805	987
100 kHz	16-QAM rate = 1/2	1 629	1 987
100 kHz	64-QAM rate = 1/2	2 453	2 987
100 kHz	64-QAM rate = 2/3	3 277	2 163
150 kHz	4-QAM rate = 1/2	1 221	1 515
150 kHz	16-QAM rate = 1/2	2 461	3 043
150 kHz	64-QAM rate = 1/2	3 701	4 571
150 kHz	64-QAM rate = 2/3	4 941	3 331

K bits of the SCH-Q/D logical channel	N Fill bits	SICH-Q/U error encoded into 16 bits	Error bits E4-E1 with a leading zero encoded into 16 bits
---------------------------------------	-------------	-------------------------------------	---

Figure D.30: Returned data for Type 26: SCH-Q/U

D.9.4.4 Type 26: SCH-Q/U with coding rate of 1 or error correction disabled

When the BS configuration requests an uplink Type 26 channel to be looped back, the SICH-Q field indicates the coding rate is 1, or the error correction bit is 0, the received channel is unscrambled. The resultant K bits received ($b_1(1), b_1(2), \dots, b_1(K)$) are included in a SCH-Q/D block as shown in figure D.31. Fill bits are set to zero. The order of the bits is shown in figure D.31. Table D.24 shows the value of K and N for each of the channel bandwidth and modulation types.

Table D.24: Value of K and N for each of the channel bandwidth and Slotinfo

Bandwidth	Slotinfo	K	N
25 kHz	4-QAM	400	8
25 kHz	16-QAM	800	16
25 kHz	64-QAM	1 200	24
50 kHz	4-QAM	816	64
50 kHz	16-QAM	1 632	128
50 kHz	64-QAM	2 448	192
100 kHz	4-QAM	1 648	176
100 kHz	16-QAM	3 296	352
100 kHz	64-QAM	4 944	528
150 kHz	4-QAM	2 480	288
150 kHz	16-QAM	4 960	576
150 kHz	64-QAM	7 440	864

K bits of the SCH-Q/U logical channel	N Fill bits
--	--------------------

Figure D.31: Returned data for Type 26: SCH-Q/U

D.9.4.5 Type 25: SCH-Q/HU with coding rates of 1/2 or 2/3 and error correction enabled

When the BS configuration requests an uplink Type 25 channel to be looped back, if the SICH-Q field indicates the coding rate is 1/2 or 2/3 and the error correction bit is 0, the received channel is unscrambled, de-interleaved, decoded and parity checked. The resultant K bits received ($b_1(1), b_1(2), \dots, b_1(K)$) are included in a SCH-Q/D block as shown in figure D.32. An error indication for the K bits is in E1. The received SICH-Q, which is 5 bits after error decoding is error encoded back to 16 bits and included with the SICH-Q error indications in E4. Fill bits and error bit E2 and E3 are set to zero. The error bits along with a leading zero are error encoded into 16 bits. The order of the bits is shown in figure D.32. Table D.25 shows the value of K and N for each of the channel bandwidth, modulation types and coding rates.

Table D.25: Value of K and N for each of the channel bandwidth and slotinfo

Bandwidth	Slotinfo	K	N
25 kHz	4-QAM rate = 1/2	57	319
25 kHz	16-QAM rate = 1/2	133	651
25 kHz	64-QAM rate = 1/2	209	983
25 kHz	64-QAM rate = 2/3	285	907
50 kHz	4-QAM rate = 1/2	141	707
50 kHz	16-QAM rate = 1/2	301	1 427
50 kHz	64-QAM rate = 1/2	461	2 147
50 kHz	64-QAM rate = 2/3	621	1 987
100 kHz	4-QAM rate = 1/2	309	1 483
100 kHz	16-QAM rate = 1/2	637	1 483
100 kHz	64-QAM rate = 1/2	965	4 475
100 kHz	64-QAM rate = 2/3	1 293	4 147
150 kHz	4-QAM rate = 1/2	477	2 259
150 kHz	16-QAM rate = 1/2	973	4 531
150 kHz	64-QAM rate = 1/2	1 469	6 803
150 kHz	64-QAM rate = 2/3	1 965	6 307

K bits of the SCH-Q/HU logical channel	N Fill bits	SICH-Q/U error encoded into 16 bits	Error bits E4-E1 with a leading zero encoded into 16 bits
---	--------------------	--	--

Figure D.32: Returned data for Type 26: SCH-Q/HU

D.9.4.6 Type 25: SCH-Q/HU with coding rate of 1 or error correction disabled

When the BS configuration requests an uplink Type 25 channel to be looped back, if the SICH field indicates the coding rate is 1 or the error correction bit is 1, then the received channel is only unscrambled. The resultant K bits received $b_I(1), b_I(2), \dots, b_I(K)$ are included in a SCH-Q/D block as shown in figure D.33. Fill bits are set to zero. The order of the bits is shown in figure D.33. Table D.26 shows the value of K and N for each of the channel bandwidth, modulation types and coding rates.

Table D.26: Value of K and N for each of the channel bandwidth and Slotinfo

Bandwidth	Slotinfo	K	N
25 kHz	4-QAM	152	256
25 kHz	16-QAM	304	512
25 kHz	64-QAM	456	768
50 kHz	4-QAM	320	560
50 kHz	16-QAM	640	1 120
50 kHz	64-QAM	960	1 680
100 kHz	4-QAM	656	1 168
100 kHz	16-QAM	1 312	2 336
100 kHz	64-QAM	1 968	3 504
150 kHz	4-QAM	992	1 776
150 kHz	16-QAM	1 984	3 552
150 kHz	64-QAM	2 976	5 328

K bits of the SCH-Q/HU logical channel	N Fill bits
---	--------------------

Figure D.33: Returned data for Type 26: SCH-Q/HU

D.9.4.7 Type 28: SCH-Q/RA with error correction enabled

When the BS configuration requests an uplink Type 28 channel to be looped back, if the error correction bit is 0, the received channel is unscrambled, de-interleaved, decoded and parity checked. The resultant K bits received $b_I(1), b_I(2), \dots, b_I(K)$ are included in a SCH-Q/D block as shown in figure D.34. An error indication for the K bits is in E1. Fill bits and error bit E2, E3 and E4 are set to zero. The error bits, along with a leading zero, are error encoded into 16 bits using the (16,5) RM code. The order of the bits is shown in figure D.34.

168 bits of the SCH-Q/RA logical channel	224 Fill bits	Error bits E4-E1 with a leading zero encoded into 16 bits
---	----------------------	--

Figure D.34: Returned data for Type 28: SCH-Q/RA

D.10 Direct Mode Operation (DMO)

D.10.0 Definitions

The abbreviation DM-MS is used throughout the present document as a generalized term to include all MSs capable of working in DMO. The full capability of any particular DM-MS is not a standardized parameter but is an issue for implementation.

Some basic assumptions on the likely types of mobile are however useful in order to define specific operational issues and where this is appropriate in the present document, the following terminology is used:

- DM-MS: generalized term for any DMO capable MS;
- DO-MS: Direct mode Only MS;
- DU-MS: DUal mode switchable MS;
- DW-MS: Dual Watch MS;
- DM-REP: Direct Mode REPeater;
- DM-GATE: Direct Mode GATEway;
- DM-REP/GATE: Direct Mode REPeater/GATEway.

Implementations which combine dual functionality in a single unit, e.g. a DM-REP and MS equipment are not considered to be distinct and separate stations, but for the purposes of the present document are considered to be combinations of those listed above.

The general term DM-MS is used as applying to all DM-MSs, but the other terms listed above may be applied where specific differentiation is necessary.

D.10.1 Direct mode only mobile station (DO-MS)

Continuous loop back in direct mode operation is not possible, because operation of traffic channels is in a true simplex mode, the same RF carrier and timeslot combination is used in both directions of a communication.

D.10.2 Dual mode switchable mobile station (DU-MS)

Loop back testing can be performed with the mode switched to V+D. As it is unlikely that the RF circuitry will change when the mode is switched to DMO, only a functional test will be required in DMO mode.

D.10.3 Dual watch mobile station (DW-MS)

Loop back testing can be performed with V+D operation activated. As it is unlikely that the RF circuitry will change when the DMO mode is active, only a functional test will be required for DMO operation.

D.10.4 Direct mode repeater (DM-REP)

The operation of a DMO repeater is to forward the information from one Direct Mode MS (DM-MS) to another DM-MS, thus if the TSS transmit section acts as the sending DM-MS and the TSS receive section acts as the receiving DM-MS a natural loop back is formed and a test mode will only be required to override authentication and encryption procedures. For TCH/S BER testing it may be necessary to disable the repeater's normal Bad Frame Erasure operation.

D.10.5 Direct mode gateway (DM-GATE)

The operation of a DMO gateway is to forward the information from a DM-MS to a SwMI (or vice versa), thus if the TSS transmitter acts as the sending DM-MS and the TSS receiver acts as the receiving BS (or vice versa) a natural loop back is formed. The test mode will only be required to indicate bad frames and bar authentication and encryption procedures.

D.10.6 Direct mode repeater/gateway combination (DM-REP/GATE)

The comments for DM-REP (clause D.10.4) and DM-GATE (clause D.10.5) shall apply.

D.10.7 DMO summary

The specification is adequate in its present form for all types of DMO equipment with the exception of DO-MS. Special conditions applicable to using the T1 test mode with DO-MS equipment are defined in clauses F.4 and F.5 of the present document. DO-MS equipment cannot be tested using the TT test mode.

NOTE: At present, there is no DO-MS equipment in the market.

Annex E (normative): Using RF loop back to test a TETRA MS

E.0 Applicability

Annex E applies to the **TETRA Test (TT) Protocol** Loopback method defined in clauses D.1 to D.6. Annex E does not apply to the T1 or T4 Loopback method defined in clauses D.7 and D.8.

E.1 Introduction

The purpose of the **RF loop back** facility using the **TT protocol** is to provide a consistent method for assessing BER and MER on TETRA mobile stations, in production and service environments, without the need for special test connectors or adapters.

The present document is a guide to how the **RF loop back** facility may be used to test a TETRA MS. A simplified view of the test configuration during RF loop back testing is shown in figures E.1 and E.2.

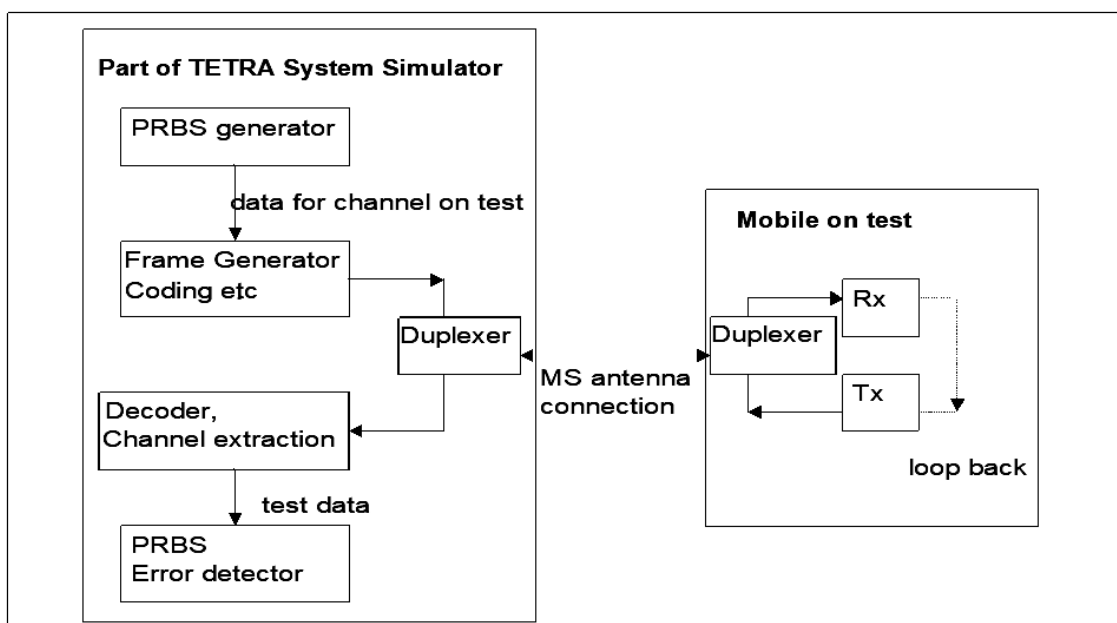

Figure E.1: RF Loop Back test configuration

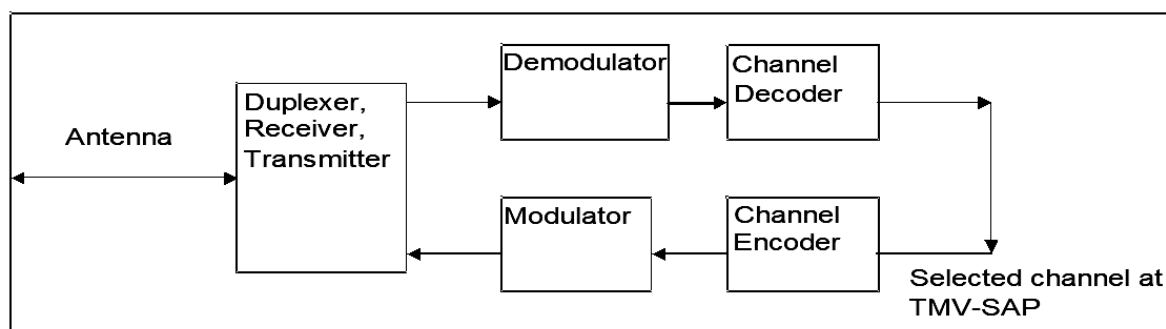

Figure E.2: Simplified diagram of MS during RF Loop Back

The message sequence and broadcast parameters used in the present document are intended as an illustration of one possible sequence of messages and set of parameters **and defines how those shall be used**, if that method is used. It is not intended to restrict the range of options used by mobile manufacturers. It is the responsibility of the **TETRA System Simulator (TSS)** designers to ensure that valid messages from the unit on test are correctly acknowledged and answered.

E.2 Expected mode of operation for testing a MS

To test a TETRA MS the TSS (acting as a base station) shall as a minimum generate in Downlink Continuous Transmission mode in a Normal Control mode with a Main Control Channel (MCCH) in time slot 1 of the main carrier.

A Broadcast Control Channel (BCCH) comprising a Broadcast Synchronization Channel (BSCH) and a Broadcast Network Channel (BNCH) shall be transmitted as a minimum to the requirements of ETSI EN 300 392-2 [1], clause 9.5.2.

Table E.1a: Example of use of TETRA frame structure for mobile testing

	TN1 (CP)	TN2 (UP)	TN3 (UP or TP)	TN4 (UP)
MN1 FN1 to FN17 see note 1	SCH/HD (null) + SCH/HD (null) <i>or signalling</i> + AACH	SCH/HD (null) + SCH/HD (null) + AACH	SCH/HD (null) + SCH/HD (null) <i>or TCH/x</i> + AACH	SCH/HD (null) + SCH/HD (null) + AACH
MN1 FN18	SCH/HD (null) + SCH/HD (null) + AACH	BSCH (sync info) + SCH/HD (null) + AACH (CLCH)	SCH/HD (null) + SCH/HD (null) + AACH	SCH/HD (null) + BNCH (sys info) + AACH
MN2 FN1 to FN17	SCH/HD (null) + SCH/HD (null) <i>or signalling</i> + AACH	SCH/HD (null) + SCH/HD (null) + AACH	SCH/HD (null) + SCH/HD (null) <i>or TCH/x</i> + AACH	SCH/HD (null) + SCH/HD (null) + AACH
MN2 FN18	BSCH (syncinfo) + SCH/HD (null) + AACH (CLCH)	SCH/HD (null) + SCH/HD (null) + AACH	SCH/HD (null) + BNCH (sys info) + AACH	SCH/HD (null) + SCH/HD (null) + AACH
MN3 FN1 to FN17	SCH/HD (null) + SCH/HD (null) <i>or signalling</i> + AACH	SCH/HD (null) + SCH/HD (null) + AACH	SCH/HD (null) + SCH/HD (null) <i>or TCH/x</i> + AACH	SCH/HD (null) + SCH/HD (null) + AACH
MN3 FN18	SCH/HD (null) + SCH/HD (null) + AACH	SCH/HD (null) + BNCH (sys info) + AACH	SCH/HD (null) + SCH/HD (null) + AACH	BSCH (sync info) + SCH/HD (null) + AACH (CLCH)
MN4 FN1 to FN17	SCH/HD (null) + SCH/HD (null) <i>or signalling</i> + AACH	SCH/HD (null) + SCH/HD (null) + AACH	SCH/HD (null) + SCH/HD (null) <i>or TCH/x</i> + AACH	SCH/HD (null) + SCH/HD (null) + AACH
MN4 FN18	SCH/HD (null) + BNCH (sys info) + AACH	SCH/HD (null) + SCH/HD (null) + AACH	BSCH (sync info) + SCH/HD (null) + AACH (CLCH)	SCH/HD (null) + SCH/HD (null) + AACH
NOTE 1: This structure of four multiframe MN1 ~ MN4 is repeated x15 to form one Hyperframe, with the Multiframe Number (MN) taking the values 1, 2, 3, 4, 5, 6, 7, 8, ..., 57, 58, 59, 60.				
NOTE 2: Mandatory mappings of BNCH, BSCH and opportunities for CLCH are shown in bold type.				

An example of how the TSS structure might look is shown in table E.1a. Here a minimum requirement is shown; there is a single RF channel with MCCH on TN1. Signalling such as registration and call set up (and mobile initial access) will be on TN1. When a traffic channel is required (in this example) it will use TN3; TN2 and TN4 are not used and transmit null PDUs. (This is only one of many examples that could be described, but this example has the benefit of simplicity and single RF channel usage.)

The Access Assignment Channel (AACH) shall allow sufficient opportunities for linearization and opportunities for a mobile to access the **TSS**.

Currently unallocated physical channels (UP) shall be filled with permitted logical control channels as indicated in ETSI EN 300 392-2 [1], clauses 9.5.2 and 9.5.3. In this simple example a SCH/HD containing a null PDU is used as follows in table E.1b.

Table E.1b: Contents of SCH/HD when used as a fill signal

Parameter	Bits	Value	Remarks
NULL PDU			
PDU type	2	00 ₂	MAC_RESOURCE
Fill bits	1	0 ₂	no fill bits
Position of grant	1	0 ₂	do not care
Encryption	2	00 ₂	No encryption
Random Access Flag	1	0 ₂	
Length	6	000010 ₂	2 octets (null PDU)
Address type	3	000 ₂	Null PDU
Fill	108	100 ... 0 ₂	1 + 107 0s

The contents of the TM_SDU(MLE_SYNC) and SYNC_PDU used for the BSCH are given in table E.2.

Table E.2: Contents of SYNC_PDU

Parameter	Bits	Value	Remarks
SYNC_PDU			
System code	4	0000 ₂	1 st release V+D
Base Colour Code	6	1 to 63	as required
Timeslot number	2		current timeslot
Frame number	5		current frame number
Multiframe number	6		current multiframe number
Sharing mode	2	00 ₂	continuous TX
TS reserved frames	3	000 ₂	do not care
U-plane DTX	1	0 ₂	not allowed
Frame 18 extension	1	0 ₂	no extension
Reserved	1	0 ₂	default
TM_SDU (D_MLE_SYNC)			
Mobile Country Code	10	001 ₁₆	MCC = 001 for test
Mobile Network Code	14	0001 ₁₆	MNC = 1 for test
Neighbour cell broadcast			
D_NWRK_BROADCAST			
supported	1	0 ₂	not supported
enquiry	1	0 ₂	not supported
Cell service level	2	00 ₂	cell load unknown
Late entry information	1	0 ₂	not supported

The contents of the TM_SDU (MLE_SYSINFO) and SYSINFO_PDU used for the BNCH are given in table E.3.

Table E.3: Contents of SYSINFO PDU

Parameter	Bits	Value	Remarks
SYSINFO_PDU			
PDU type	2	10 ₂	Broadcast PDU
Broadcast type	2	00 ₂	SYSINFO PDU
Main carrier	12		as required
Frequency band	4		as required
Offset	2	00 ₂	0 kHz offset
Duplex spacing	3		as required
Reverse operation	1		as required
No. of common 2ndry CCHs in use	2	00 ₂	none
MS_TXPWR_MAX_CELL	3	001 ₂	15 dBm default or as required
RXLEV_ACCESS_MIN	4	0000 ₂	-125 dBm default or as required
ACCESS_PARAMETER	4	0000 ₂	-53 dB default or as required
RADIO_DOWNLINK_TIMEOUT	4	0000 ₂	disabled default or as required
Hyperframe/CCK flag	1	0 ₂	hyperframe
Hyperframe number	16		current hyperframe number
Optional field flag	2	10 ₂	access code A
<i>Default definition for access code A</i>			
IMM (immediate)	4	1111 ₂	immediate access
WT (waiting time)	4		as required
Nu (access attempts)	4		as required
Framelength factor	1	0 ₂	multiply by 1
Timeslot pointer	4	0000 ₂	same as downlink
Minimum priority	3	000 ₂	lowest priority (0)
<i>TM_SDU (MLE_SYSINFO)</i>			
Location area	14	Any	as required
Subscriber class	16	FFFF ₁₆	all classes
BS service details			
Registration	1	1 ₂	registration mandatory
De-registration	1	1 ₂	de-registration mandatory
Priority cell	1	1 ₂	priority cell
Minimum mode service	1	0/1 ₂	as required
Migration	1	1 ₂	supported
Roaming	1	1 ₂	supported
TETRA voice service	1	1 ₂	supported
Circuit mode data service	1	1 ₂	supported
Reserved	1	0 ₂	default value
SNDCP service	1	0/1 ₂	as required
Air interface encryption	1	0 ₂	not available
Advanced link supported	1	0/1 ₂	as required

The Access Assignment Channel (AACH) during this initial period will allow access to all mobiles during Frames 1 to 17 on TN1, allow linearization on all Frame 18s containing a BSCH, and on other frames will mark the AACH as access reserved.

Initially, TN1 frames may be marked access reserved, to enable the TSS to control when the first access burst is sent, but this would need to be carefully handled to stop the TETRA equipment on test timing out because it had not confirmed the test mode setting.

As a minimum requirement, Access Code A is required, and in a test situation this will normally be the only Access Code used. Base frame length will be kept to a minimum to ensure fast test times. Initially, four AACH types are required; see tables E.4 to E.7. Once messages are exchanged, other AACH values will be required.

Table E.4: AACH Frame 1 to 17 TN1

Information element	Value	Remark
Header	00 ₂	Downlink usage common control Uplink access rights - common only
Access field 1- Access code Base framelength	00 ₂ 0011 ₂	Access code A Base framelength 1 subslot
Access field 2- Access code Base framelength	00 ₂ 0011 ₂	Access code A Base framelength 1 subslot

Table E.5: AACH Frame 1 to 17 TN2, 3 and 4

Information element	Value	Remark
Header	11 ₂	Downlink usage defined by field 1 Uplink usage rights defined by field 2
Field 1-Downlink usage marker	000000 ₂	Unallocated
Field 2-Uplink usage marker	000000 ₂	Unallocated

Table E.6: AACH Frame 18 TN1, 2, 3 and 4 (not containing BSCH)

Information element	Value	Remark
Header	00 ₂	Uplink access rights - common only
Access field 1- Access code Base framelength	00 ₂ 0000 ₂	Access code A Reserved subslot
Access field 2- Access code Base framelength	00 ₂ 0000 ₂	Access code A Reserved subslot

Table E.7: AACH Frame 18 TN1, 2, 3 and 4 (containing BSCH)

Information element	Value	Remark
Header	00 ₂	Uplink access rights - common only
Access field 1- Access code Base framelength	00 ₂ 0001 ₂	Access code A CLCH subslot
Access field 2- Access code Base framelength	00 ₂ 0000 ₂	Access code A Reserved subslot

The output level of the **TSS** shall be adjusted to give a suitable input level to the MS on test. This should initially be in the range -90 dBm to -60 dBm, to ensure error free registration and test mode confirmation.

E.3 Recognition of TETRA Test mode by MS

The mobile is switched on and set to **TETRA Test mode**. This could be, for example, by pressing a sequence of keys in a manner similar to calling up a supplementary service, e.g. *99*.

On recognizing that it has been set to **TETRA Test mode** the mobile shall immediately start timer **T_TEST**. It shall then search for a MCCH with a MCC of 001 and a MNC of 1.

When allowed by the **TSS**, the mobile shall attempt to register with the **TSS**. It shall not attempt to authenticate the **TSS** or use encryption on the air interface.

The first message sent by the mobile shall be a MAC ACCESS in a control burst with the MM layer 3 message U_LOCATION_UPDATE_DEMAND. It will treat the **TSS** as a visited location and the address type it shall use shall be the USSI (migrating MS unexchanged address) this will normally be the same as its ISSI (individual short subscriber identity). In a case where the mobile has yet to be given an ITSI (individual TETRA subscriber identity) an address of all 0 s may be used.

The registration with identity exchange procedure then continues, as indicated in ETSI EN 300 392-1 [8], clause G.6.1.2.1, with the **TSS** simulating the base station and SwMI. Details of the message contents are to be found in ETSI EN 300 392-2 [1], clauses 16.9.2 and 16.9.3.

The procedure is successfully completed when the **TSS** has sent a **D_LOCATION_UPDATE_ACCEPT** message which the mobile has acknowledged. The **TSS** shall then send a TT layer 3 message **D_TEST_MODE_CONFIRM_COMMAND** which the mobile acknowledges with a **TEST_MODE_CONFIRM** message. At this point the mobile shall stop timer **T_TEST** and go into the test mode operating state.

During this procedure the **TSS** will use the **MAC_RESOURCE** header and modify the **AACH** to reserve subslots to allow the mobile to transmit, and indicate when messages are being sent to the mobile. The use of the **AACH** shall be as given in the TETRA specification ETSI EN 300 392-2 [1], clause 21.4.7.

In **TETRA Test mode** the MS shall accept and generate all normal valid commands, with the exception of some Mobility Management (MM) commands and with the addition of commands with the TT protocol discriminator, some of the exceptions being:

- it shall not action a **D_DISABLE** command neither temporary nor permanent;
- it shall not encrypt messages on the air interface;
- it shall not attempt to authenticate the **TSS**.

The full list of exceptions is given in clause D.3.2.1.

If the timer **T_TEST** expires before the above procedure is completed then the mobile shall revert to **normal operational mode** i.e. start searching for a control channel allowed by its subscription parameters. To retry to set into test mode would require the user to set test mode again, i.e. in the example the key sequence *99* would need entering again.

With the test mode confirmed the mobile shall be in the idle and registered state listening for paging messages etc. It shall also have the ability to place and answer calls. If the MS has any kind of visual display, it should indicate that it is set in test mode. This could be for example by displaying the word "TEST" in the display panel, or for a MS with no display panel this could be by flashing an indicator light in a particular manner.

E.4 Using loop back to test traffic channels

E.4.0 Loop back commands

To test a mobile on a traffic channel, for example to perform a BER test, requires that an individual call be in progress and then a **RF loop back** invoked. The call can be placed from the **TSS** or the mobile.

Where the mobile has duplex capability, the call shall be set up in duplex mode. To maintain the channel during a simplex call, message trunking is used. Message trunking is indicated by the **MAC_RESOURCE** PDU at an "over" when the PDU does not have a channel allocation returning the mobile back to the **MCCH**. In the simple scenario described the traffic channel will be allocated to *TN3* on the main carrier.

To invoke the loop back a **D_LOOP_COMMAND** message is sent to the mobile, this shall indicate that the (current) traffic channel is to be looped back. The message may indicate in the "loopback type" element that **BFI** (bad frame indication) is to be used; this only applies to a speech traffic channel and the "loopback type" element should be ignored for data traffic channels. The mobile shall respond with a **U_LOOP_CONFIRM** message. The mobile shall also loop the received traffic channel to the transmitter as indicated in the main text of the present document. During loop back the traffic channel received is decoded to type-1 bits at the **TMV-SAP** level and then the type-1 bits are re-encoded and returned on an identical traffic channel to the **TSS**.

3 examples are outlined below:

- TCH/7,2;
- TCH/S;
- TCH/2,4 with N = 8.

During the call the TSS shall use normal procedures on the AACH, this shall normally involve allocating a usage marker to the call and marking, via the AACH, the uplink and downlink slots to be used with the usage marker.

During loop back the uplink and downlink slots shall be marked for use as a traffic channel, via the AACH. In the example considered the AACH will mark all TN3 slots, both uplink and downlink, of the main carrier in frames 1 to 17 with the usage marker allocated for the call.

The loop back command is "carried" in a MAC_RESOURCE PDU and for the case where a simplex call is in progress the channel allocation element shall allocate the resources for both up and down link. See tables E.8 and E.9 for typical messages.

Table E.8: Example of loop command in MAC_RESOURCE enabling duplex operation

Parameter	Bits	Value	Remarks
MAC_RESOURCE PDU			
PDU type	2	00 ₂	MAC_RESOURCE
Fill bit indicator	1	0 ₂	fill bits not present
Position of grant	1	1 ₂	on allocated channel
Encryption mode	2	00 ₂	not encrypted
Random access flag	1	0 ₂	do not care
Length indication	6	001100 ₂	12 bytes
Address type	3	110 ₂	SSI + usage marker assignment
Address	30	x...x ₂	SSI + usage marker
Power control flag	1	0 ₂	no power control (may be used if required)
Slot granting flag	1	0 ₂	no slot granting element
Channel allocation flag	1	1 ₂	channel allocation follows
Channel allocation element			
Allocation type	2	00 ₂	replace current channel with specified channel
Time slot assigned	4	0010 ₂	TN 3 assigned (or as required)
Up/downlink assigned	2	11 ₂	both uplink and downlink assigned
CLCH permission	1	1 ₂	immediate permission
Cell change flag	1	0 ₂	no cell change
Carrier number	12	x...x ₂	as required (the channel in current use)
Extended carrier number flag	1	0 ₂	no extended carrier numbering
Monitoring pattern	2	00 ₂	no monitoring pattern
Frame 18 monitoring pattern	2	11 ₂	3 monitoring patterns (all frame 18s)
TM_SDU (D_LOOP COMMAND)			
LLC header			
LLC PDU type	4	0000 ₂	BL_ADATA without FCS
N(R)	1	1/0 ₂	as required
N(S)	1	1/0 ₂	as required
MLE header			
Protocol discriminator	3	111 ₂	TETRA Test entity
TT PDU			
PDU type	5	00100 ₂	D_LOOP COMMAND
Loopback type	5	00001 ₂	current TCH without frame erasure
O_bit	1	0 ₂	optional elements not present
Null PDU			
PDU type	2	00 ₂	MAC_RESOURCE
Fill bit indicator	1	0 ₂	none
Position of grant	1	0 ₂	do not care
Encryption mode	2	00 ₂	not encrypted
Random access flag	1	0 ₂	do not care
Length indication	6	000010 ₂	null PDU (2 bytes)
Address type	3	000 ₂	null PDU
Fill bits	12	100000 ₂ 000000 ₂	required to pad out to 124 bits for SCH/HD

Table E.9: Example of a MAC block containing a TT U-TEST MODE CONFIRM PDU

	Information element	Length	C/O/M	Remarks
MAC HEADER	PDU type	2	M	MAC-DATA = 00 ₂
	Fill bit indication	1	M	Fill bits not present = 0 ₂
	Encrypted flag	1	M	Not encrypted = 0 ₂
	Address type	2	M	SSI = 00 ₂
	Address	24	M	ASSI
	Length indication or capacity request	1	M	Length indication next = 0 ₂
	Length indication	6	C	Length of MAC header + TM SDU 15 octets in this example = 001111 ₂
LLC HEADER	LLC PDU type	4	M	BL-ADATA without FCS = 0000 ₂
	N(R)	1	M	1 ₂ or 0 ₂ as appropriate
	N(S)	1	M	1 ₂ or 0 ₂ as appropriate
MLE HEADER	Protocol Discriminator	3	M	Tetra Test entity = 111 ₂
TT PDU	PDU type	5	M	10001 ₂ = U-TEST MODE CONFIRM
	Confirm	2	M	00 ₂ = confirmed
	TETRA equipment identity	60	M	15 digit TEI
	MS power class	4	M	e.g. 0011 ₂ = class 3
	Receiver class	2	M	e.g. 01 ₂ = class B
	O_bit	1	M	0 ₂ = optional elements not present
NULL PDU	PDU type	2	M	MAC-DATA = 00 ₂
	Fill bit indication	1	M	Fill bits present = 1 ₂
	Encrypted flag	1	M	Not encrypted = 0 ₂
	Address type	2	M	SSI = 00 ₂
	Address	24	M	ASSI
	Length indication or capacity request	1	M	Length indication next = 1 ₂
	Length = Null PDU	6	M	000000 ₂ = null PDU
	Fill bits	111	C	"1 ₂ " + 110 ₂ "0 ₂ "s
	Total MAC block	268		

M = mandatory;
C = conditional;
O = optional.

E.4.1 TCH/7,2

The **TSS** shall take 432 bits from a repeated standard 511 bit PRBS; it shall scramble the bits according to ETSI EN 300 392-2 [1], clause 8.2.5.2. These scrambled bits shall form the 2 blocks *BKN1* and *BKN2* which shall be transmitted in a normal continuous downlink burst forming part of the downlink traffic channel (*TN3* frames 1 to 17 in the simple scenario considered). The **TSS** shall then take the next 432 bits of the PRBS and repeat the process to produce the next burst in the traffic channel.

The mobile shall receive the bursts containing the traffic channel and extract the 432 bits of the blocks *BKN1* and *BKN2* and de-scramble them. These recovered 432 bits are re-scrambled and shall form the 2 blocks *BKN1* and *BKN2* which shall be transmitted in a normal discontinuous uplink burst. (This conceptually loops back the signal at the TMV-SAP point, the same result is achieved if the scrambled received bits are used to form the two blocks *BNK1* and *BNK2* for retransmission). Although ideally the loop backed signal should occur in the same frame as it was received, a constant delay is acceptable.

While in loop back it shall be optional whether the mobile delivers the 7,2 kb/s data to the user.

The **TSS** shall receive the burst with the returned traffic channel and extract the 432 bits of the blocks *BKN1* and *BKN2* and de-scramble them. The resulting 432 bits shall be checked for errors, the errors shall be totalled over a number of returned bursts of the traffic channel to enable the BER to be calculated.

E.4.2 TCH/S

The TSS shall take 2 contiguous samples of 137 bits from a repeated standard 511 bit PRBS, these shall represent 2 frames from a speech encoder. Sample 1 forms the Type-1 bits A1 to A137, sample 2 forms the Type-1 bits B1 to B137. The bits are then reordered, parity and tail bits added, convolution coding applied, interleaved and finally scrambled (naming and numbering notation and coding procedure is that used in ETSI EN 300 395-2 [12], clause 5). The 432 scrambled bits shall form the 2 blocks *BKNI* and *BKN2* which shall be transmitted in a normal continuous downlink burst forming part of the downlink traffic channel (*TN3* frames 1 to 17 in the simple scenario considered). The TSS shall then take the next 2 contiguous samples of 137 bits of the PRBS and repeat the process to produce the next burst in the traffic channel.

The mobile shall receive the bursts containing the traffic channel and extract the 432 bits of the blocks *BKNI* and *BKN2* and decode them. The result after de-scrambling, de-interleaving and de-convolution shall be 286 type-2 bits. The 60 class 2 bits shall have their parity bits calculated and checked against the received parity bits. If the parity bits do not match then this shall be an indication of a bad frame for when this is required. The type-1 bits shall be extracted from the type-2 bits. The resulting 2 speech frames are used as the inputs to the encoding process (This conceptually loops back the signal at the TMV-SAP point, the same result is achieved if the type-2 bits are looped back with parity bits recalculated). The speech frames are encoded and the resulting 432 bits shall form the 2 blocks *BKNI* and *BKN2* which shall be transmitted in a normal discontinuous uplink burst. Although ideally the looped back signal should occur in the same frame as it was received, a constant delay is acceptable.

In the case where the D_LOOP_COMMAND message has requested BFI the return signal may be modified. If the parity check on the class 2 bits fail or some other indication of an unusable traffic sample is indicated by the mobile and BFI is requested then the two return samples should be set to all 1s prior to encoding for retransmission.

While in loop back it shall be optional whether the mobile delivers "speech" to the user. (It is probably advisable not to "deliver" the speech to avoid uncomfortable noises to any listener).

The TSS shall receive the burst with the returned traffic channel and extract the 432 bits of the blocks *BKNI* and *BKN2* and decode them. The resulting two 137 bit speech frames shall be checked for errors; the errors shall be totalled over a number of returned bursts of the traffic channel to enable the BER to be calculated. Where BFI has been requested the TSS shall recognize the samples set to all "1"s as bad frames, calculating the BER only in those frames which do not indicate BFI.

E.4.3 TCH/2,4, N = 8

The TSS shall take 144 bits from a repeated standard 511 bit PRBS, it shall add 4 tail bits and RCPC (convolution) code with $r = 148/432$. The resultant 432 bit type-3 bits are interleaved over 8 blocks. A completed block shall contain an equal number of convoluted bits from 8 samples of the PRBS. Each completed block of 432 bits is further interleaved to form the type-4 bits which shall then be scrambled (these processes are according to ETSI EN 300 392-2 [1], clause 8). These scrambled bits shall form the 2 blocks *BKNI* and *BKN2* which shall be transmitted in a normal continuous downlink burst forming part of the downlink traffic channel (*TN3* frames 1 to 17 in the simple scenario considered). The TSS shall continue taking contiguous 144 bit samples of the PRBS and repeat the processes described.

The mobile shall receive the bursts containing the traffic channel and extract the 432 bits of the blocks *BKNI* and *BKN2* and de-scramble them. The bits shall be block de-interleaved. Then the information shall be further de-interleaved over the 8 blocks originally contributing to the block. When an originating block is completed it shall be de-convoluted and the tail bits removed to obtain the 144 data bits. The recovered data along with other retrieved samples shall then be re-encoded as described for the TSS for retransmission. (This conceptually loops back the signal at the TMV-SAP point).

While in loop back it shall be optional whether the mobile delivers the 2,4 kb/s data to the user.

The TSS shall receive the burst with the returned traffic channel and extract the 432 bits of the blocks *BKNI* and *BKN2* and de-scramble them etc. The resulting 144 type-1 bits shall be checked for errors, the errors shall be totalled over a number of returned bursts of the traffic channel to enable the BER to be calculated. Interleaving over 8 blocks causes an overall delay of at least 16 frames between the original sample and the received sample for checking. The delay may be longer but shall be constant.

E.4.4 Control messages during loop back of traffic channels

During the period in which error tests are in progress, there shall normally be no control messages sent. If however the **TSS** requires to send a control message, for example to request a change in power level, the burst containing the message will have training sequence number 2 indicating channel stealing (STCH). The mobile shall decode and action the message, it may stop, temporarily, the loop back mechanism until the signalling sequence is completed i.e. the message has been acknowledged or answered. It is the responsibility of the **TSS** to allow for this interruption in any error counting procedure, etc.

If during the loop back the mobile transmits a control message, for example an attempt to invoke a supplementary service is made, the **TSS** shall acknowledge the message and may indicate to the test operator via the **TSS** MMI that an unexpected interruption has occurred. Whether the test in progress is terminated, repeated or continued depends on the type of interruption and is a matter for the designer of the **TSS**.

Annex F (normative): Direct Mode (DM) Testing

F.1 Scope

Annex F defines the test limits and measurement methods to be used for the testing of radio aspects of TETRA terminals which are capable of operating in Direct Mode Operation (DMO). It applies to the following types of Direct Mode terminal:

- DO-MS,
- DU-MS,
- DW-MS,
- DM-REP,
- DM-GATE,
- DM-REP/GATE.

F.2 Definitions, symbols and abbreviations

Refer to ETSI EN 300 396-1 [i.2] and ETSI EN 300 396-2 [7], clause 3.1 for common definitions.

F.3 General

With the exception of DO-MS equipment, all equipment which is capable of DMO is also capable of TETRA trunked mode V+D operation, and therefore has to pass the radio aspects tests in the present document. DO-MS equipment is required by ETSI EN 300 396-2 [7] to fulfil most of the radio requirements of trunked mode Class B V+D MS equipment, the main exceptions being power control and reception of the AACH logical channel. Therefore, this annex requires all equipment which is capable of DMO to meet the present document, with certain exceptions for DO-MS equipment.

NOTE: For DM-MS equipment which is designed specifically as DO-MS (rather than being a DU-MS with the V+D operation disabled in software), it is possible that this equipment will not be physically capable of operating in the frequency duplex mode required to conduct tests under clauses 8 to 10.

Equipment which is capable of DMO is required by ETSI EN 300 396-2 [7] to meet slightly more stringent test limits for transmitter output power below maximum power class. Therefore, this annex requires all equipment which is capable of DMO to meet the present document using the more stringent limits where applicable.

Direct Mode Operation involves two radio aspects which are not covered by the present document, unsynchronized transmission and direct mode burst profiles. Therefore, this annex requires all equipment which is capable of DMO to provide an additional DMO Test Transmit Mode, and to meet the requirements of two additional tests.

F.4 Radio test modes

For the purpose of testing, all equipment which is capable of DMO shall provide test modes which enable all of the MS V+D tests in clauses 8 to 10 to be performed as specified (see note in table F.1), except as shown in table F.1, and shall also provide a DMO test transmit mode as defined in clause F.6.1.

Table F.1: Test Case Exceptions for equipment capable of Direct Mode Operation

Clause	Equipment Type	Test Case Exception
8.1.1.1 a)	DO-MS (one power class)	The DO-MS shall disregard the T1 level, Access_parameter and MS_TXPWR_MAX_CELL parameters, and shall set its transmitter output power to its nominal power class.
8.1.1.1 a)	DO-MS (more than one power class)	The DO-MS shall either set its power according to test case 1 or shall be switched to its highest power class.
8.1.1.1 b)	DO-MS (one power class)	The test shall not be repeated for test cases 2 to 7.
8.1.1.1 b)	DO-MS (more than one power class)	All of the other power classes shall be tested by the DO-MS either setting its power according to test cases 2 to 7 as appropriate, or by being switched to its other power classes.
8.3	DO-MS (one power class)	The test shall not be repeated for test case 7.
8.3	DO-MS (more than one power class)	The test shall be repeated by the DO-MS either setting its lowest power class in response to test case 7 or by being switched to its lowest power class.
10.5	DO-MS	This test shall not be performed.
NOTE: The T1 signal supplied shall be identical to the normal T1 signal used for V+D testing. FN18 will contain BSCH (not SCH/S) scrambled with all-zeroes scrambling code, and BNCH/T (not SCH/H) scrambled with the normal extended colour code obtained from the BSCH (not all zeroes scrambling code). The bursts transmitted by the DM-MS in this test mode shall be Normal Uplink Bursts or Control Bursts as indicated in the BNCH/T information (not the Direct Normal Burst and Direct Synchronization Burst).		

F.5 Test conditions

All equipment which is capable of DMO shall be tested according to clauses 8, 9, 10 and 11, except as shown in table F.1, and shall meet the test limits defined in clause 7, except as shown in table F.2.

Table F.2: Test limit exceptions for equipment capable of Direct Mode Operation

Clause	Equipment Type	Test Limit Exception
7.1.1.2	All types	The limits for the MS power class (specified in ETSI EN 300 396-2 [7], clause 6) apply to all power levels tested which correspond to power classes of the equipment.
7.1.5.2	All types	See note 1.
7.2.2.2	DO-MS	Table A.2 applies (as MS receiver V+D Class B, see note 2).
7.2.3.2	DO-MS	Table A.2 and table A.6 apply (as MS receiver V+D Class B, see note 2), but with no requirement to measure AACH.
7.2.4.2	DO-MS	Table A.2 applies (as MS receiver V+D Class B, see note 2).
7.2.5.2	DO-MS	Table A.2 applies (as MS receiver V+D Class B).
7.2.6.2	DO-MS	Table A.2 applies (as MS receiver V+D Class B).
7.2.7.2	DO-MS	Table A.2 applies (as MS receiver V+D Class B).
NOTE 1: In the case where a DM-MS transmits on a DM channel frequency which is within its normal V+D MS Tx band, then the limits shall apply symmetrically to both sides of the MS Tx band, where f_{rb} denotes the frequency offset corresponding to the near edge of the received band or 5 MHz (10 MHz for frequencies above 520 MHz) whichever is greater. All levels are expressed in dBc relative to the actual transmitted power level, and in any case no limit tighter than -55 dBm for offsets $\leq f_{rb}$ or -70 dBm for offsets $> f_{rb}$ shall apply. In other cases, the -100 dBc requirement shall apply outside of the frequency range f_x which comprises the range of frequencies over which the equipment is able to transmit within the TETRA standard, plus a guard band of 5 MHz on either side as shown in ETSI EN 300 396-2 [7], figure 6. In any case no limit tighter than -70 dBm shall apply.		
NOTE 2: Where propagation condition TU50 is specified in tables A.2 and A.6 the test shall be performed using propagation condition DR50 defined in ETSI EN 300 396-2 [7], clause 6.		

F.6 Additional tests for equipment which is capable of Direct Mode Operation

F.6.1 DMO test transmit mode

The manufacturer shall provide the means to operate the equipment under test in DMO test transmit mode over the frequency range which includes at least the declared DMO RF carrier frequency range. DMO test transmit mode shall be selected using the method provided by the manufacturer.

In DMO test transmit mode, the equipment under test shall be configured to transmit a signal as follows. In timeslot 1 of frame 18, a Direct Synchronization Burst (DSB) containing SCH/S and SCH/H information shall be transmitted. In timeslot 1 of frames 1 to 17, a Direct Normal Burst (DNB) containing channel type 1 (TCH/7,2) information shall be transmitted. In timeslots 2 to 4 of frames 1 to 18, nothing shall be transmitted, except that the equipment may transmit a DSB in timeslot 3 of frames 6, 12 and 18, and a linearization burst in timeslot 3 of frame 3. This sequence may be preceded by continuous DSB transmission. A bit stream, produced by repeating a pseudo random sequence with a length of 511 bits according to Recommendation ITU-T O.153 [2], shall be used as the information to be transmitted over the TCH/7,2 logical channel.

The equipment shall set its transmit power according to its DMO power class, specified in ETSI EN 300 396-2 [7], clause 6. If the equipment has more than one DMO power class, the highest power class shall be selected using the method provided by the manufacturer.

In DMO test transmit mode, the equipment under test is not provided with a test signal from the test system, and derives its frequency and timing information from its own internal frequency reference.

F.6.2 DMO transmitter output power profile

F.6.2.1 DMO transmitter output power profile, limit values

The following requirement shall be met.

The transmitter output power versus time shall be within the power time mask specified in ETSI EN 300 396-2 [7], clause 6, figure 7, measured through the TETRA filter, refer to clause B.1.2.2, under normal test conditions. The time periods t_1 , t_2 and t_3 in ETSI EN 300 396-2 [7], clause 6, figure 7 are defined in ETSI EN 300 396-2 [7], clause 6, table 6.

F.6.2.2 DMO transmitter output power profile, method of measurement

This test shall be performed under normal test conditions specified in clause 6, on the middle radio frequency channel in the band in which the equipment is intended for DMO.

- a) The DMO equipment shall be connected to the test system, and shall be placed in DMO test transmit mode on its highest DMO power class.
- b) The sampling system shall capture a representation of the DMO transmit burst's amplitude and timing (excluding any LCH transmissions). The procedure shall be repeated for 200 bursts and the test system shall calculate the following two parameters:
 - b1) the average power versus time profile during time periods t_1 and t_3 (figure 7 in ETSI EN 300 396-2 [7]), extended at least 5 symbol periods before the start of t_1 and at least 5 symbol periods after the end of t_3 , sampled at a rate equal to or greater than the symbol rate, where each point represents the average power per sample, as estimated from the 200 arrays;
 - b2) the average power over the useful part of a burst (the modulation symbol times $SN0$ to $SNmax$ defined in ETSI EN 300 396-2 [7], clause 9), sampled at symbol rate at symbol time, further averaged over the 200 burst measurements. This single power value shall be used as the 0 dB reference for the power versus time profile determined in step b1) above.

F.6.3 DMO Carrier frequency accuracy

F.6.3.1 DMO Carrier frequency accuracy, limit values

The carrier frequency error in any burst shall be within $\pm 1,0$ kHz measured under normal and extreme test conditions.

F.6.3.2 DMO Carrier frequency accuracy, method of measurement

This test shall be performed under normal and extreme test conditions specified in clause 6, on the middle radio frequency channel in the band in which the equipment is intended for DMO. The measurement described here is performed on direct mode normal bursts, defined in ETSI EN 300 396-2 [7], clause 9. The sampling system in annex B, clause B.1.2 shall be employed.

- a) The DMO equipment shall be connected to the test system, and shall be placed in DMO test transmit mode on its highest DMO power class.
- b) The sampling system shall capture a representation of the DMO transmit burst's modulation symbol $Z(k)$ at sampling times t_k (symbol by symbol) where t_k is the symbol time corresponding to the k^{th} symbol. For each symbol the sampling system shall measure the phase rotation θ which is caused by the frequency difference between the DMO equipment and the sampling system, as defined in ETSI EN 300 396-2 [7], clause 6. The sampling system shall calculate the frequency error df for the burst as follows:

$$df = 1/(2\pi T SN_{max}) \sum_{k=1}^{SN_{max}} \theta(k)$$

where df is expressed in Hz, T is the symbol duration in seconds, $\theta(k)$ is expressed in radians, and SN_{max} is the number of symbols in a burst, defined in ETSI EN 300 396-2 [7], clause 9.

- c) The procedure described in step b) shall be repeated for 20 bursts.

F.6.4 DM-MS Slave synchronization accuracy

F.6.4.1 DM-MS Slave synchronization accuracy, definition

DM-MS slave synchronization accuracy (error) is defined as a difference between the actual transmitted carrier frequency and the nominal synchronized carrier frequency, where the nominal synchronized carrier frequency is defined as the nominal transmit carrier frequency subject to the same frequency variation as the carrier frequency of the signal received by the DM-MS.

- NOTE: When the DM-MS equipment is required to transmit in slave mode, it is important that it synchronizes with and transmits back to the master on the master's frequency and timing. This happens, for example, during pre-emption request, changeover request (when the channel is reserved), timing change request, responding to call set-up with presence check and when responding to acknowledged short data message.

F.6.4.2 DM-MS Slave synchronization accuracy, limit values

The DM-MS slave synchronization accuracy in any burst shall be within ± 100 Hz, measured under normal test conditions.

F.6.4.3 DM-MS Slave synchronization accuracy, method of measurement

- a) The test system shall transmit test signal T1 at a carrier frequency which is varied by $+1,0$ kHz from the nominal carrier frequency, using a frequency reference for the timebase used to generate the modulation symbols which is varied by $+2,0$ ppm.

- b) The test defined in clause 10.2.1 shall be performed using the T1 signal subject to frequency variation as defined in step a).
- c) Steps a) and b) shall be repeated with a carrier frequency variation of -1,0 kHz and a timebase frequency reference variation of -2,0 ppm.

Annex G (informative): Change requests

The present document includes change requests as presented in table G.1.

Table G.1: Change requests

No	CR vers.	Standard Version	Clauses affected	Title	CR Status
001		V2.3.1	2, 7.1.1.2, 7.1.2.1, 8.1.1, 8.1.2, 9.6, C.3.1	Update of table and figure references to ETSI EN 300 392-2 [1] and other editorial updates	Approved
401	11	V3.1.1	2, 2.1, 2.2, 5.3.5.1.1, 10.2.1, 10.2.2, 10.2.3, 10.2.4, C.5.1, E.3	Editorial correction	WG3 approved 080624
402	10	V3.1.1	7.1.1.2, 7.1.2.1, 8.1.1.1	Air to ground requirements	WG3 approved 080624
403	10	V3.1.1	7.2.4.3.1, A.2	TEDS adjacent channel rejection values	WG3 approved 090903
404	10	V3.1.1	Annex C	TEDS TTCl	WG3 approved 090401
405	11	V3.1.1	A.2	Clause A.2 tables	WG3 approved 090401
406	10	V3.1.1	3.3, D.10, F.1, F.2, F.3, F.4, F.5, F.6	Update DMO test clauses regarding latest published DMO standards	WG3 approved 090507
407	05	V3.1.1	5.2.1, A.3	BNCH/T definition and testing of TEDS header logical channels	
408	10	V3.1.1	A.2	Question marks in the table A.13	WG3 approved 090903
409	20	V3.2.1	5.3.5.1	Correction in T4 signal references in 5.3.5.1	WG3 approved 17.06.2014
501	10	V3.3.1	Forward, 1, 2.2, 3.1, 4.1, 4.1.1, 4.1.3, 4.2.1, 4.2.3, 5, 5.0, 5.2, 5.2.0, 5.2.1, 5.2.1.0, 5.3.2, 5.3.2.0, 5.3.5, 5.3.5.0, 5.3.5.1, 5.3.5.1.0, 6.1, 6.2, 6.2.2, 6.3, 6.3.0, 7.1.8.2.3, 8.1, 8.1.0, 8.7, 8.7.0, 8.8, 8.8.0, 9.2, 9.2.0, 9.3, 9.3.0, 9.4, 9.4.0, 9.5, 9.5.0, 9.6, 9.6.0, 9.7, 9.7.0, 10.1, 10.1.0, 10.2, 10.2.0, 11, 11.0, 11.1, 11.2, 11.3, B.1.1, C, C.2, C.3.1, C.3.2, C.4.3.1, C.5.2.1, C.5.2.1.0, C.6, C.6.0, C.8, C.8.0, C.8.1, D, D.0, D.1, D.1.0, D.1.3, D.2, D.3, D.3.0, D.3.1, D.3.2, D.3.2.0, D.5, D.7, D.7.0, D.7.2, D.8, D.8.0, D.8.4, D.8.4.0, D.8.5, D.9, D.9.0, D.9.4, D.9.4.0, D.10, D.10.0, E, E.0, E.1, E.4, E.4.0, F.1, F.3	Removal of status as the TETRA conformance specification	

History

Document history		
Edition 1	March 1996	Publication as ETSI ETS 300 394-1 (Historical)
V2.1.1	September 2000	Publication
V2.2.1	September 2000	Publication (Withdrawn)
V2.1.2	December 2000	Publication as ETSI EN 300 394-1
V2.3.1	December 2000	Publication
V2.3.1	April 2001	Publication as ETSI EN 300 394-1
V2.4.1	February 2006	Publication as ETSI EN 300 394-1
V3.1.1	November 2007	Publication as ETSI EN 300 394-1
V3.2.1	October 2012	Publication as ETSI EN 300 394-1
V3.3.1	April 2015	Publication as ETSI EN 300 394-1
V4.1.1	March 2021	Publication